

Last version of this manual
IP2433EN • 2024-06-11

Ditec



Ditec AIR600B **Ditec AIR1000B**

Technical manual

Automation for sectional doors

(Translation of the original instructions)

Index

General safety precautions	3
Declaration of incorporation of partly completed machinery	4
UK Declaration of Conformity	5
1. Technical data	6
2. Product description	7
3. Operating Instructions	7
4. Machinery Directive	7
5. Applications with generic sectional doors	8
6. Dimensions	10
7. Installation type	11
8. Main components	12
9. Installation	13
9.1 Assembly guide	13
9.2 Tensioning the belt	14
9.3 Assembling the automation	15
9.4 Rail mechanical installation	16
9.5 Assembling and fastening the arm	21
9.6 Cables passage	22
10. Electrical connections	23
10.1 LCU60E electronic board	24
10.2 Reports	25
11. Commands	25
12. Outputs and accessories	26
12.1 Wiring the accessories	27
13. Navigation buttons	34
14. Self-learning of the stroke	36
15. Memorizing / Deleting remote controls	38
15.1 Memorizing remote controls	38
15.2 Deleting remote controls	38
16. Using of the menus	39
16.1 Switching the display ON and OFF	39
16.2 Navigation keys	39
16.3 Shortcuts	40
16.3.1 Calibration reset	40
16.3.2 System restart	40
16.3.3 Radio remote control storage via control panel	40
16.3.4 Wi-fi reset	40
17. Parameters LCU60E	41
17.1 Main level menu	41
17.2 Frequent use menu map	41
17.4 Frequent use parameters description	44
17.4 Complete menu - parameters description	46
18. Alarms and faults	58
19. Maintenance	61
20. Installation of accessories	62
20.1 Installation of the adapter AIRSB for up-and-over doors	62
20.2 Installation of the high-brightness LED light 3500 lms (ref. LEDLGT4K35)	63
20.3 Installation of AIR motor on rail TOP803T3 - TOP803T4 (ref. TSRFK)	63

Legend



This symbol indicates instructions or notes relating to safety which require special attention.



This symbol indicates useful information for the correct operation of the product.



Indicates the default parameters value

General safety precautions



ATTENTION! Important safety instructions. Please follow these instructions carefully.

Failure to observe the information given in this manual may lead to severe personal injury or damage to the equipment. Keep these instructions for future reference.

This manual and those for any accessories can be downloaded from www.ditecautomations.com

This installation manual is intended for qualified personnel only • Installation, electrical connections and adjustments must be performed by qualified personnel, in accordance with Good Working Methods and in compliance with the current regulations • Read the instructions carefully before installing the product. Wrong installation could be dangerous • Before installing the product, make sure it is in perfect condition.



The packaging materials (plastic, polystyrene, etc.) should not be discarded in the environment or left within reach of children, as they are a potential source of danger • Do not install the product in explosive areas and atmospheres: the presence of inflammable gas or fumes represents a serious safety hazard • Make sure that the temperature range indicated in the technical specifications is compatible with the installation site • Before installing the motorization device, make sure that the existing structure, as well as all the support and guide elements, are up to standards in terms of strength and stability. Verify the stability and smooth mobility of the guided part, and make sure that no risks of fall or derailment subsist. Make all the necessary structural modifications to create safety clearance and to guard or isolate all the crushing, shearing, trapping and general hazardous areas • The motorization device manufacturer is not responsible for failure to observe Good Working Methods when building the frames to be motorized, or for any deformation during use • The safety devices (photocells, safety edges, emergency stops, etc.) must be installed taking into account the applicable laws and directives, Good Working Methods, installation premises, system operating logic and the forces developed by the motorized door or gate • The safety devices must protect against crushing, cutting, trapping and general danger areas of the motorized door or gate. Display the signs required by law to identify hazardous areas • Each installation must bear a visible indication of the data identifying the motorized door or gate • Before connecting the power supply, make sure the plate data correspond to those of the mains power supply. An omnipolar disconnection switch with a contact opening distance of at least 3 mm must be fitted on the mains supply. Check that there is an adequate residual current circuit breaker and a suitable overcurrent cutout upstream of the electrical installation in accordance with Good Working Methods and with the laws in force • When requested, connect the motorized door or gate to an effective earthing system that complies with the current safety standards • Before commissioning the installation to the end user, make sure that the automation is adequately adjusted in order to satisfy all the functional and safety requirements, and that all the command, safety, and manual release devices operate correctly.



During maintenance and repair operations, cut off the power supply before opening the cover to access the electrical parts • The protection cover of the operator must be removed by qualified personnel only.



The electronic parts must be handled using earthed antistatic conductive arms. The manufacturer of the motorization declines all responsibility if component parts not compatible with safe and correct operation are fitted • Only use original spare parts for repairing or replacing products • The installer must supply all information concerning the automatic, manual and emergency operation of the motorized door or gate, and must provide the user with the operation and safety instructions.

Declaration of incorporation of partly completed machinery (Directive 2006/42/EC, Annex II-B)

We,
ASSA ABLOY Entrance Systems AB
Lodjursgatan 10
SE-261 44 Landskrona
Sweden

declare, under our sole responsibility, that the type of equipment with the name:

Ditec AIR600 - AIR1000 Residential garage door drives with radio remote control
complies with the following directives and their amendments:

2006/42/EC Machinery Directive (MD), regarding the following essential health and safety requirements: 1.1.2, 1.1.3, 1.2.1, 1.2.2, 1.2.3, 1.2.4.2, 1.2.6, 1.3.9, 1.4.3, 1.7.2, 1.7.3, 1.7.4, 1.7.4.1, 1.7.4.2.

2014/30/EU Electromagnetic Compatibility Directive (EMCD)

2014/53/EU Directive on Radio Equipment (RED)

2011/65/EU Restriction of Hazardous Substances (RoHS 2)

2015/863/EU Restriction of Hazardous Substances (RoHS Amendment 2)

Harmonised European standards which have been applied:

EN 60335-1:2012+A11:2014+A13:2017+A1:2019+A14:2019+A2:2019+A15:2021+A16:2023

EN 55014-1:2021 EN 55014-2:2021

ETSI EN 300 220-2 v3.2.1 ETSI EN 300 220-1 v3.1.1

ETSI EN 300 328 v2.2.2 ETSI EN 301 489-17 v3.2.4

ETSI EN 301 489-3 v2.3.2 ETSI EN 301 489-1 v2.2.3

EN IEC 62311:2020 EN IEC 62368-1:2020+A11:2020

Other standards or technical specifications which have been applied:

EN IEC 60335-2-95:2023+A11:2023

EN IEC 60335-2-103:2023+A1:2023+A2:2023+A2:2023+A11:2023

EN 12453:2017+A1:2021 IEC 60335-1:2010+A1+A2

IEC 60335-2-95:2019 IEC 60335-2-103:2015+A1:2017+A2:2019

FCC CFR 47 - Part 15 Subpart B

ICES-003 Issue 7:2020

EC type examination or certificate issued by a notified or competent body (for full address, please contact ASSA ABLOY Entrance System AB) concerning the equipment.

The manufacturing process guarantees that the equipment complies with the technical documentation.

Responsible for the technical documentation:

Matteo Fino
Ditec S.p.A.
Largo U. Boccioni, 1
21040 Origgio (VA)
Italy

Signed on behalf of ASSA ABLOY Entrance Systems AB by:

Place Date
Origgio 2024-06-11

Signature
Matteo Fino

Position
CEO Ditec

© ASSA ABLOY, All rights reserved

IP2433EN

UK Declaration of Conformity

We:

ASSA ABLOY Entrance Systems AB
Lodjursgatan 10
SE-261 44 Landskrona
Sweden

Declare under our sole responsibility that the types of equipment with names:

Ditec AIR600 - AIR1000 Residential garage door drives with radio remote control
complies with the following directives and their amendments:

- Supply of Machinery (Safety) Regulations 2016
- Electromagnetic Compatibility Regulations 2016
- Radio Equipment Regulations 2017
- The Restriction of the Use of Certain Hazardous Substances in Electrical and Electronic Equipment Regulations 2012 (RoHS)

Harmonized European standards that have been applied:

EN 60335-1:2012+A11:2014+A13:2017+A1:2019+A14:2019+A2:2019+A15:2021+A16:2023
EN 55014-1:2021 EN 55014-2:2021
ETSI EN 300 220-2 v3.2.1 ETSI EN 300 220-1 v3.1.1
ETSI EN 300 328 v2.2.2 ETSI EN 301 489-17 v3.2.4
ETSI EN 301 489-3 v2.3.2 ETSI EN 301 489-1 v.2.2.3
EN IEC 62311:2020 EN IEC 62368-1:2020+A11:2020

Other standards or technical specifications which have been applied:

EN IEC 60335-2-95:2023+A11:2023
EN IEC 60335-2-103:2023+A1:2023+A2:2023+A2:2023+A11:2023
EN 12453:2017+A1:2021 IEC 60335-1:2010+A1+A2
IEC 60335-2-95:2019 IEC 60335-2-103:2015+A1:2017+A2:2019
FCC CFR 47 - Part 15 Subpart B
ICES-003 Issue 7:2020

The manufacturing process ensures the compliance of the equipment with the technical file.

Responsible for technical file:



Matteo Fino
Ditec S.p.A.
Largo U. Boccioni, 1
21040 Origgio (VA)
Italy

Signed for and on behalf of ASSA ABLOY Entrance Systems AB by:

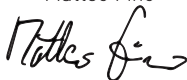
Place	Date	Signature	Position
Origgio	2024-06-11	Matteo Fino	CEO Ditec



1. Technical data

	AIR600	AIR1000
Power supply	100 V~ / 240 V~, -10%/ +10%, 50/60 Hz	100-120 V~ / 200-240 V~ (selectable by switch), 50/60 Hz i in case of 120 V power supply, switch the selector of the power supply unit
Power	100 W	150 W
Motor power supply	24 V	
Control panel	LCU60	
Power supply for accessories	24 V $\overline{\text{~}}$ / 0,3 A max 2 s 24 V $\overline{\text{~}}$ / 0,15 A continuous	
Standby	< 0,6 W for AIR600B < 0,8 W for AIR1000B	Networked Equipment (unplugged accessories)
Thrust	600 N	1000 N
Opening speed	8-22 cm/s adjustable - 20 cm/s (Default)	
Closing speed	8-22 cm/s adjustable - 10 cm/s (Default)	
Maximum door area (*)	12 m ²	17 m ²
Maximum door weight	130 kg	200 kg
Service class	INTENSIVE (tested up to 200,000 cycles)	
Intermittence	S2 = 60 min (T= 25°C) S3 = 75% (T= 25°C)	
Cycle/hour **	70 (T= 25°C)	
Continuous cycles **	100 (T= 25°C)	
Working temperature (T)	 -20°C  +55°C	
Degree of protection	IP20	
Noise level L _{PA}	<55 dB (A) (operator only)	
Remote control functions / programmable keys	Code BIXMR2 100= (RD → MU → MU/10) 200= (RD → MU → MU/20)	
Radio frequency	433.92 MHz default (RD → FG → 43) 868.35 MHz (RD → FG → 86)	i RCB100E receiver module included
Maximum remote control range	50 m	
Courtesy light	Built in: LED 1750 lms	

**indicative cycles considering a 2350 mm high door and factory settings (default opening speed of 20 cm/s and closing speed of 10 cm/s). Speeds are configurable up to 22 cm/s. With higher speeds, the number of cycles increases. A cycle is considered an opening maneuver followed by a closing maneuver

i * the maximum door area was calculated based on a weight of 10.9 kg/m²

	TS100X3 - TS150X2	TS100X4 - TS200X2
Track system length	3300 mm	4400 mm
Maximum carriage stroke	2875 mm	3975 mm
Maximum door height	2350 mm	3450 mm

2. Product description

The automation is suitable for use with balanced sectional doors and counterweighted overhead doors (with optional accessory).

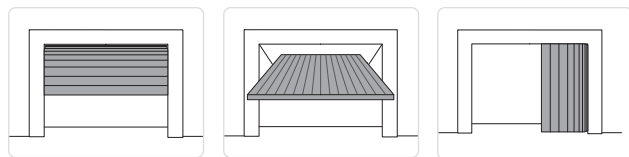

3. Operating Instructions

USE: For single-family/multi-family entrances with heavy use.

- The performance characteristics refer to the recommended weight (approx. 2/3 of the maximum permitted weight). When used with the maximum permitted weight, a reduction in the above mentioned performance levels can be expected.
- The service class, running times and number of consecutive cycles are merely indicative, having been statistically determined under average operating conditions and therefore not necessarily applicable to specific conditions of use.
- Each automatic entrance has variable elements such as friction, balancing and environmental factors, all of which may substantially alter the performance characteristics or working life of the entrance itself or its components (including the automatic devices). The installer should apply suitable safety conditions for each particular installation

4. Machinery Directive

Pursuant to Machinery Directive (2006/42/EC) the installer who automatize a door or gate has the same obligations as the manufacturer of machinery and as such must:

- prepare the technical file which must contain the documents indicated in Annex V of the Machinery Directive;
(The technical documentation must be kept and placed at the disposal of competent national authorities for at least ten years from the date of manufacture of the motorized door);
- draw up the EC Declaration of Conformity in accordance with Annex II-A of the Machinery Directive and deliver it to the customer;
- affix the EC marking on the motorized door in accordance with point 1.7.3 of Annex I of the Machinery Directive.

5. Applications with generic sectional doors

Maximum door dimensions - AIR600B (max door weight = 130 kg)

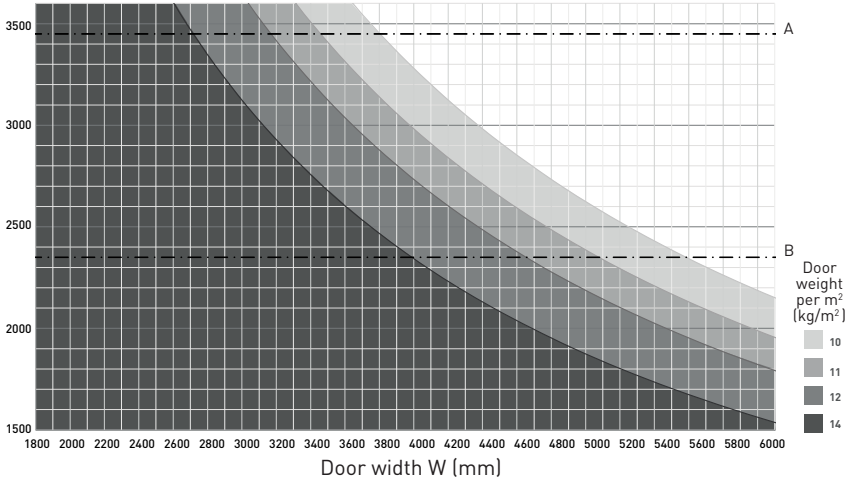

A - H max TS100X4 - TS200X2 = 3450 mm

B - H max TS100X3 - TS150X2 = 2350 mm

Maximum door dimensions - AIR1000B (max door weight = 200 kg)

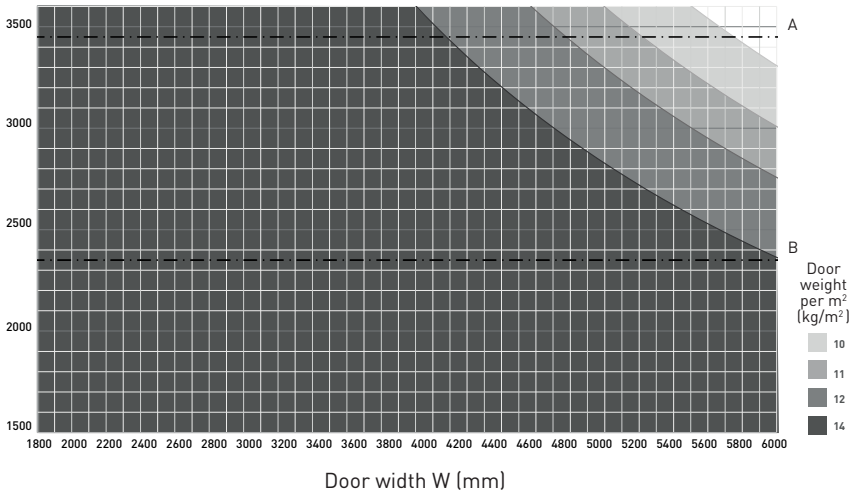

- ▲ **Example 1: sectional door 3.5 m wide and 2.3 m high, weight 12 kg/m²**
It is possible to use AIR600B with TS100X3 rail because it is within the area formed by the 12 kg/m² curve
- **Example 2: sectional door 3.5 m wide and 2.7 m high, weight 12 kg/m²**
It is possible to use AIR600B with TS100X4 rail because it falls within the area formed by the 12 kg/m² curve
- **Example 3: sectional door 4 m wide and 2.6 m high, weight 14 kg/m²**
It is NOT possible to use AIR600B with TS100X4 rail because it is NOT within the area formed by the 14 kg/m² curve.
It is recommended to use AIR1000B.

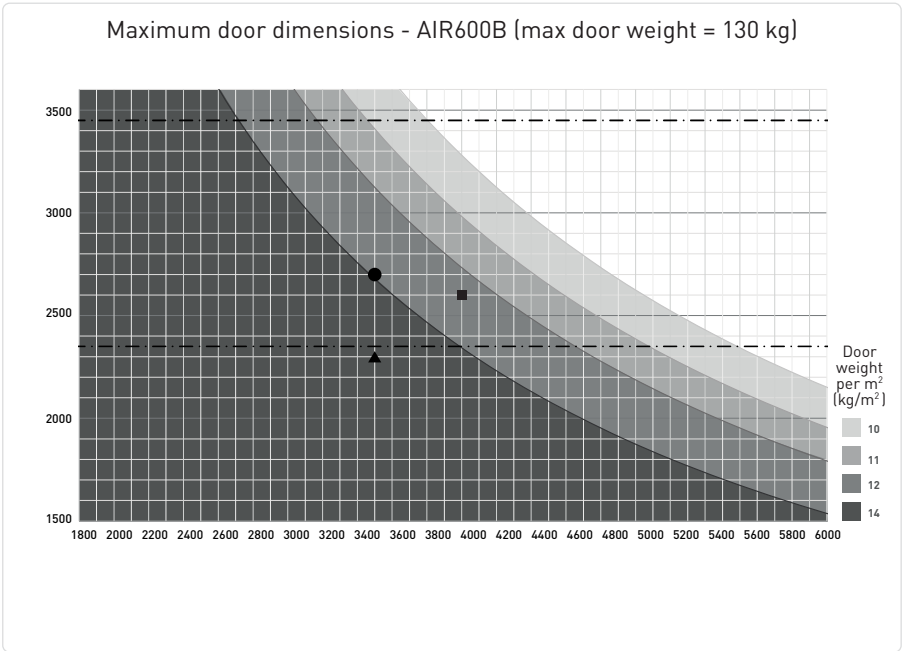

6. Dimensions

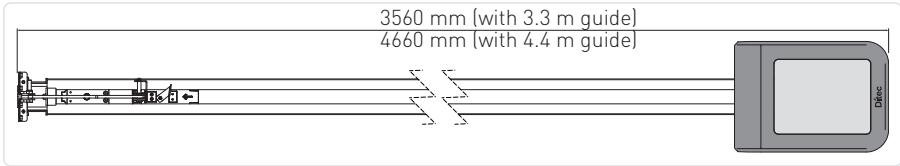
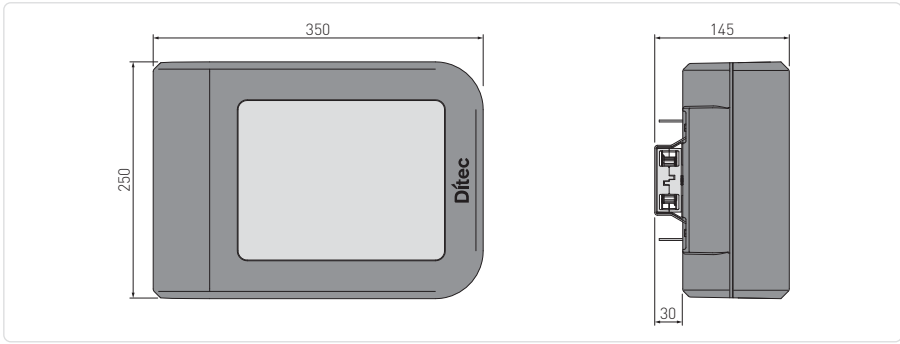

7. Installation type

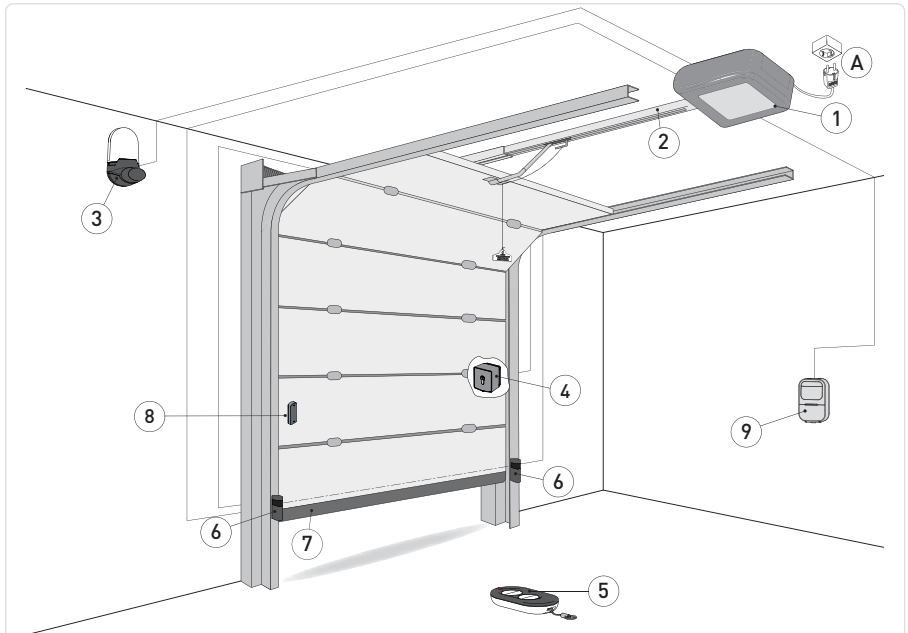

Ref.	Code	Description	Cable
1	Ditec AIR600B Ditec AIR1000B	Automation + control panel	3G x 1.5 mm ²
A		Connect the power supply to a suitable earthed socket, about 10-50cm from the pulling unit fixing position.	
2	TS100X3 - TS150X2 TS100X4 - TS200X2	Belt drive system with 3,3 m steel guide Belt drive system with 4,4 m steel guide	
3	FLM FL24	Flashing light Antenna (integrated in the flashing light)	2 x 1 mm ² RG-58 coax cable (50 Ω)
4	AXK4 AXK5M AXK5N AXK5NM AXK5NI AXR7	Digital combination wireless keypad Wall-mounted key-operated selector switch with European cylinder Semi-recessed key-operated selector switch with European cylinder Wall-mounted key-operated selector switch without cylinder Semi-recessed key-operated selector switch without cylinder RFID reader unit	/ 4 x 0.5 mm ² 5 x 0.5 mm ²
5	ZEN	Transmitter	/
6	LIN2 LIN2B AXP2 LAB4	4-wire photocells	4 x 0.5 mm ²
	LIN3	2-wire photocells with auto-test	2 x 0.5 mm ²
7	SOFAP20 SOF2M20-SOF3M20 S0FA15-S0FA20-S0FA25	Pre-assembled passive safety edge Active edge flush with mechanical contact and microswitches Resistive safety edge 8.2kΩ	2 x 0.5 mm ² min
8	GOPAVT/GOPAVRS/GOPAVR	Radio system for safety edges	/
9	WS3	Wall-Station	2 x 0.5 mm ² min

IP2433EN

8. Main components

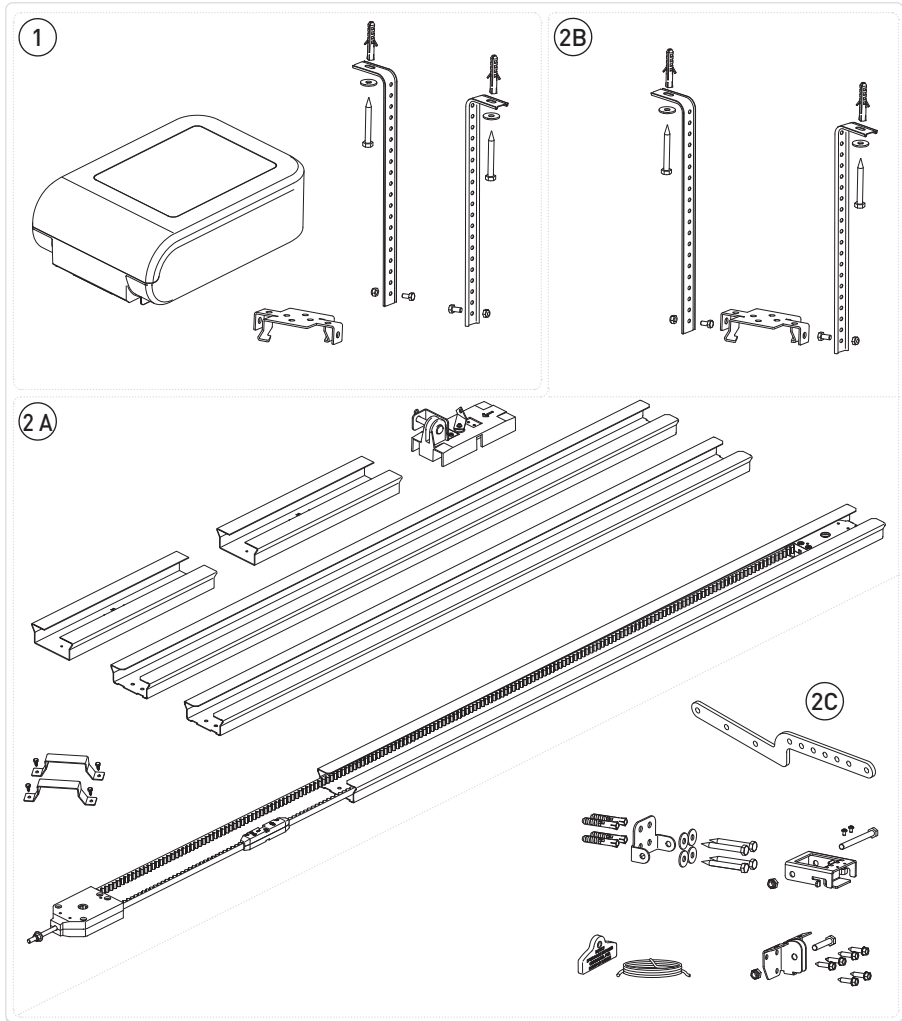

Ref.	Description
1	Automation
2A	Drive system
2B	Ceiling fixing system
2C	Guide and arm fixing brackets

9. Installation

9.1 Assembly guide

Assemble the drive unit as shown in the figures.

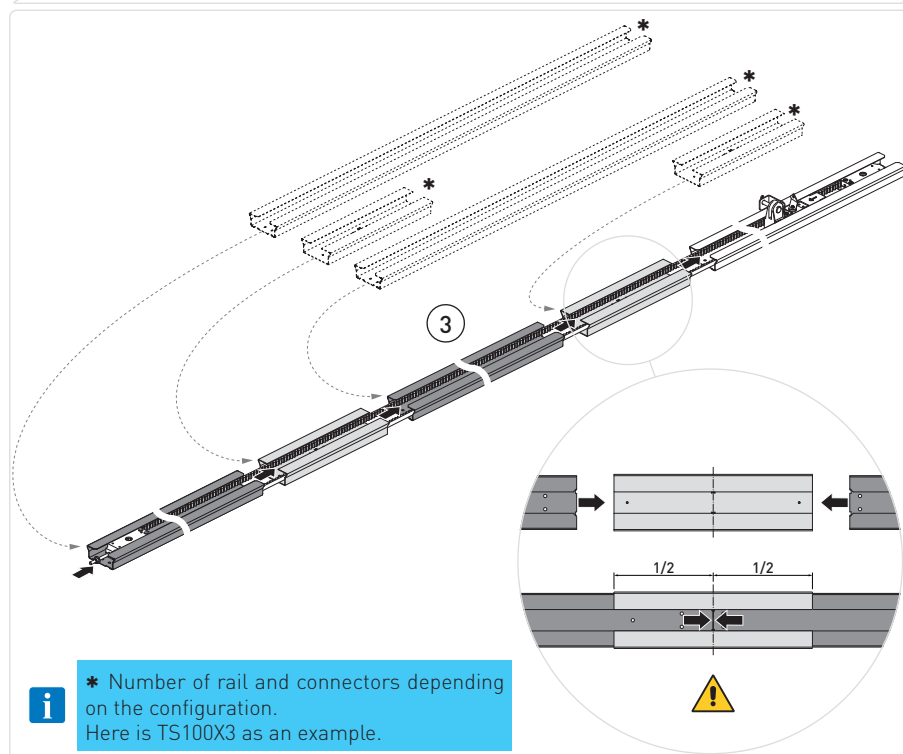
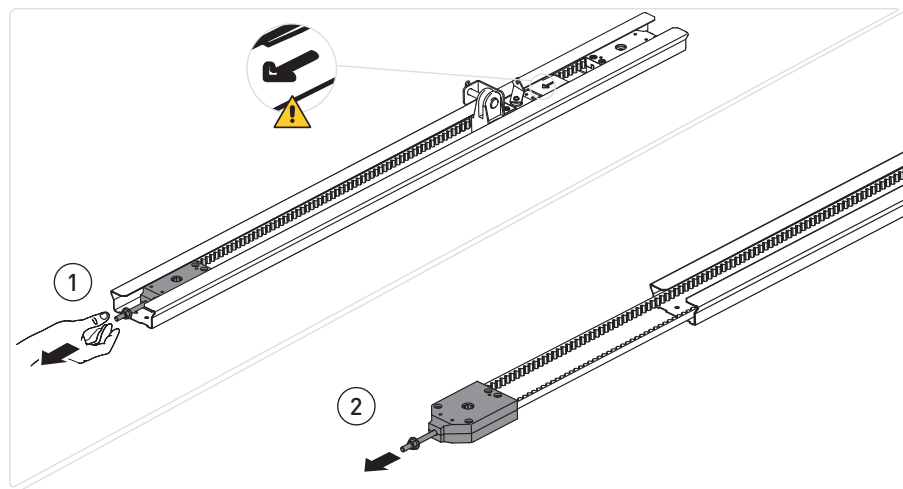

IP2433EN

9.2 Tensioning the belt

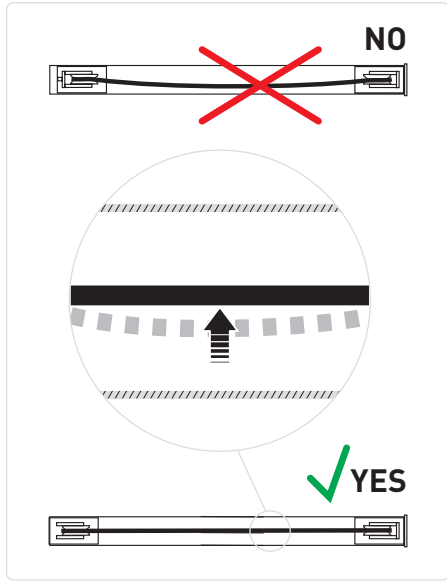
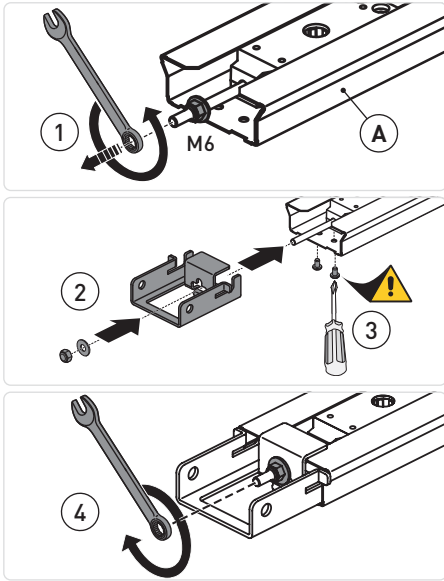

Tighten the locking nut until the belt is correctly tensioned [X] within the guide.

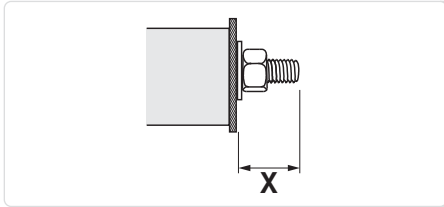

A	X
TS150X2	12-15 mm
TS100X3	12-15 mm
TS100X4	15-18 mm
TS200X2	15-18 mm

9.3 Assembling the automation

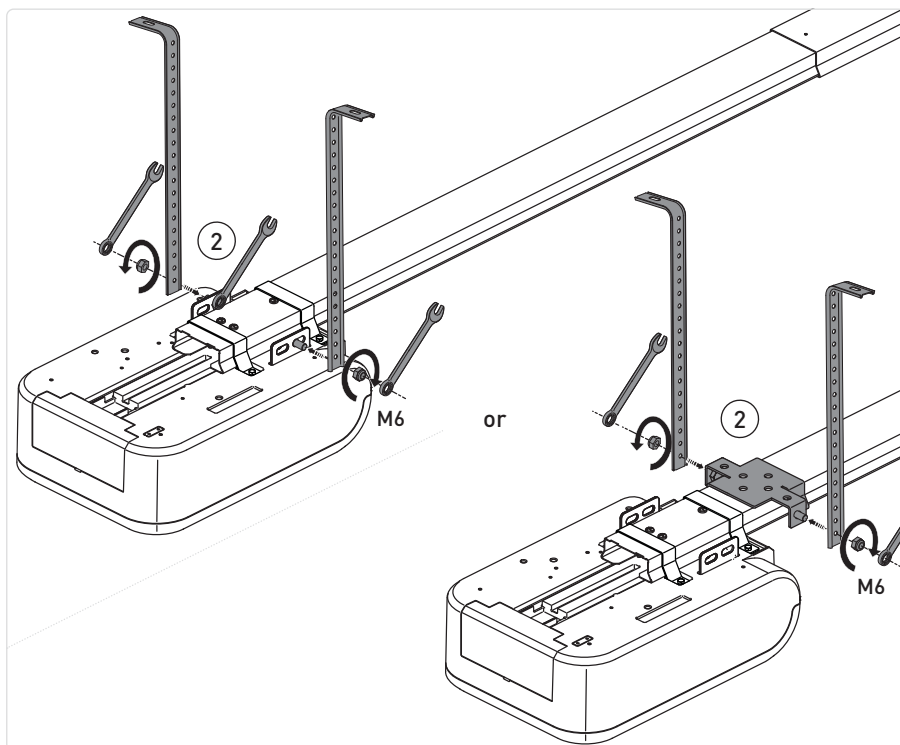
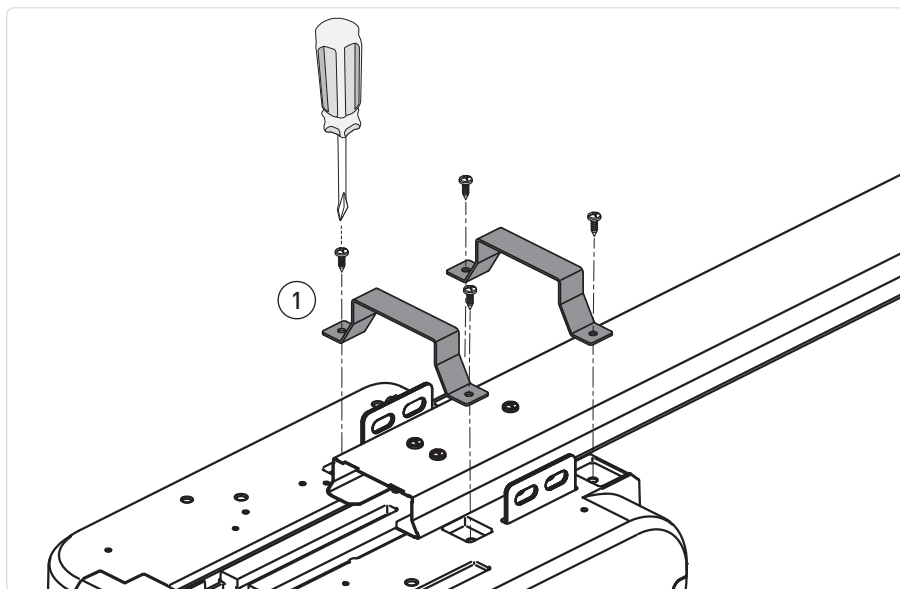

9.4 Rail mechanical installation

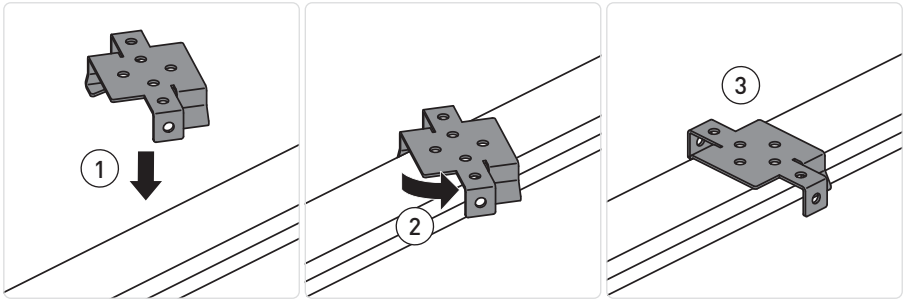

TS100X3

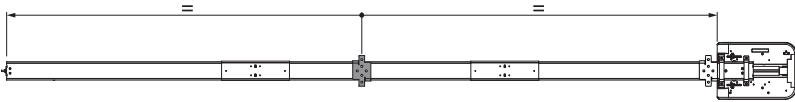

TS100X4

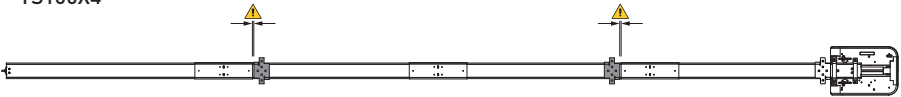

TS150X2

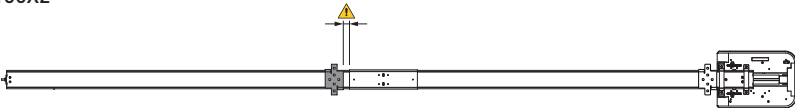

TS200X2

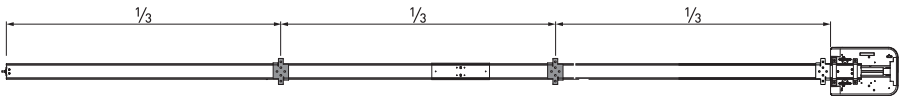

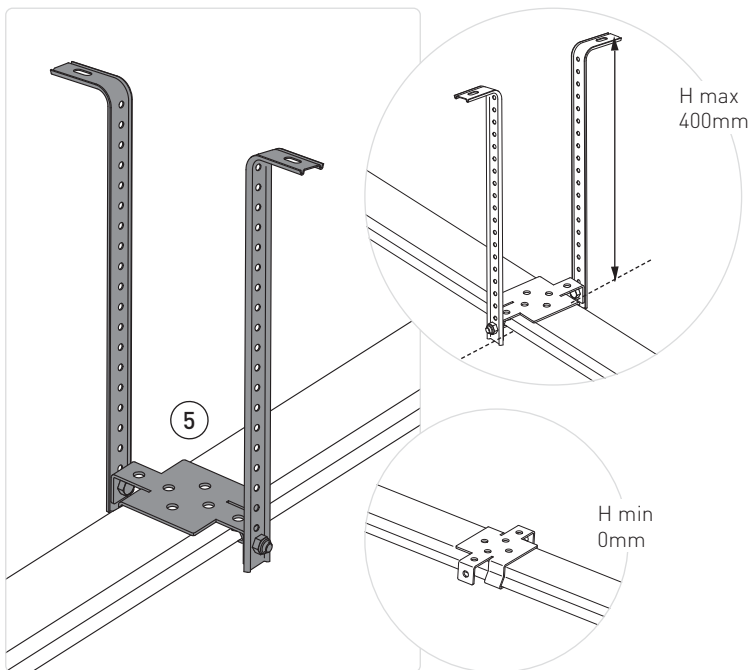
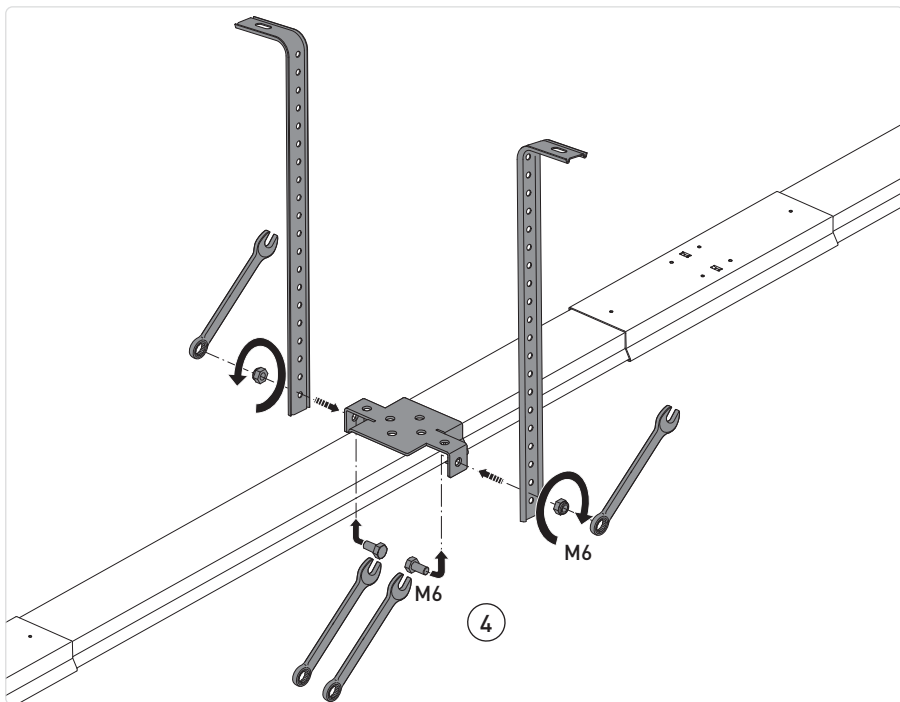

IP2433EN

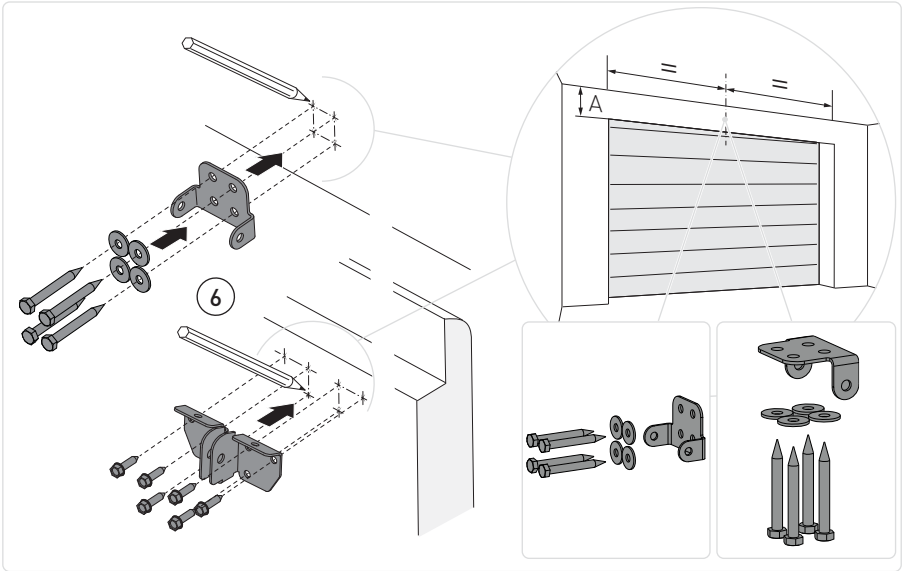
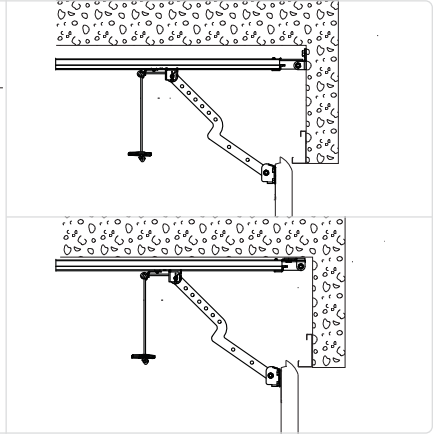
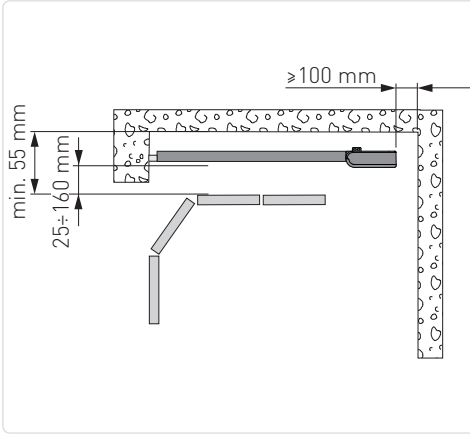

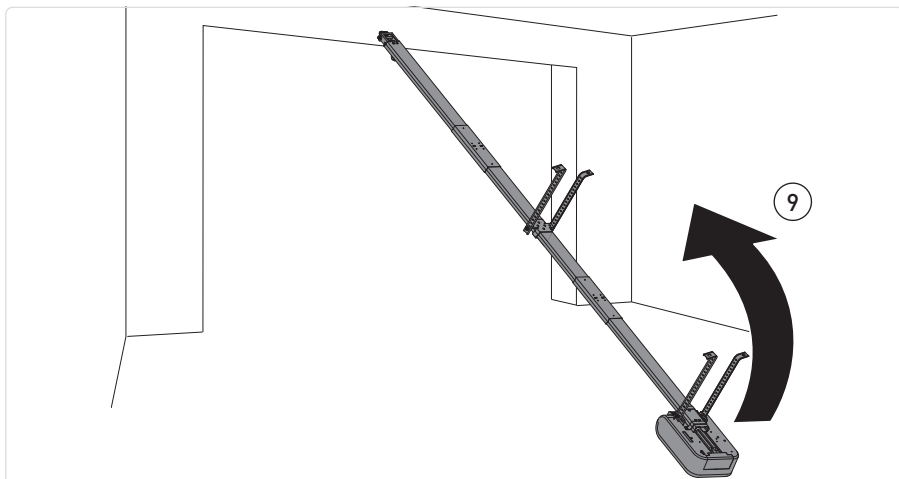
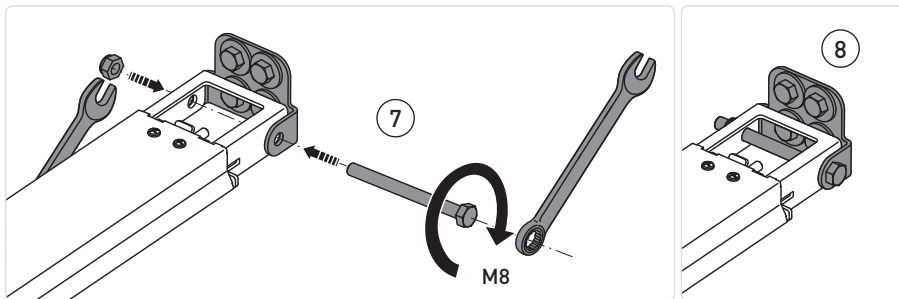

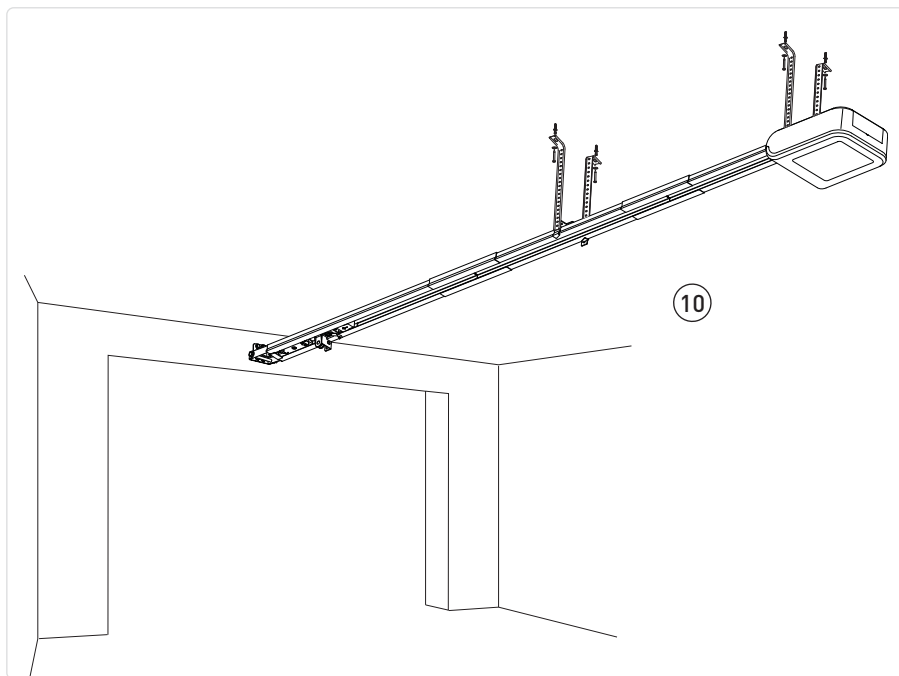

i In the example TS100X3.

- Check the stability of the door, and make sure it moves smoothly.
- It must be possible to open and close the door easily and smoothly by hand.
- The automation must only be installed in dry places.
- With the pulling unit on the ground, fix the guide to the wall.
- Raise the pulling unit and bend the brackets as necessary (any excess parts can be removed), then attach to the ceiling.

9.5 Assembling and fastening the arm

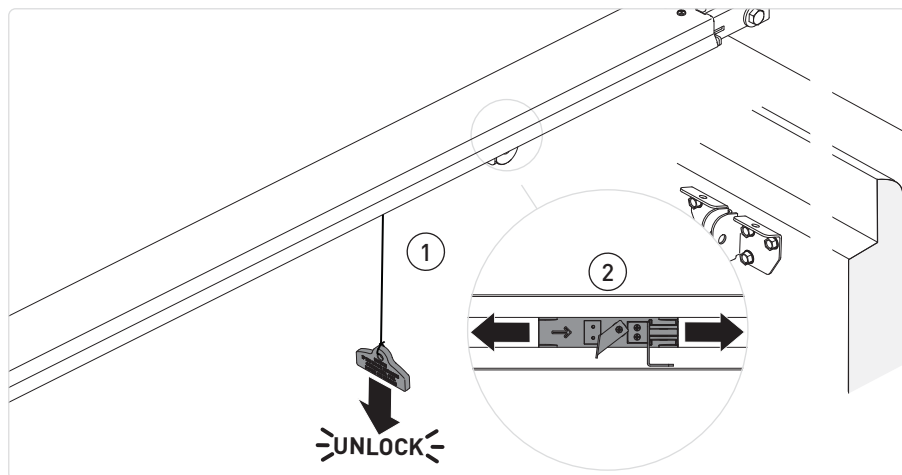

- Unlock the automation by pulling the cord downwards until the lock release lever is triggered

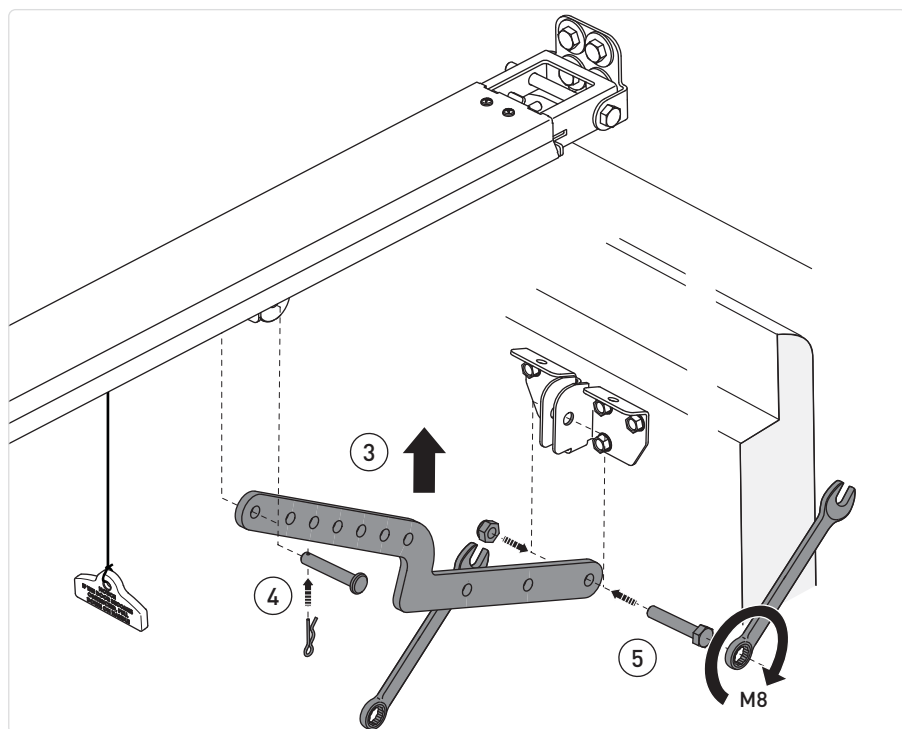

- Bring the carriage near the closed door, and fix the arm as shown above.

9.6 Cables passage

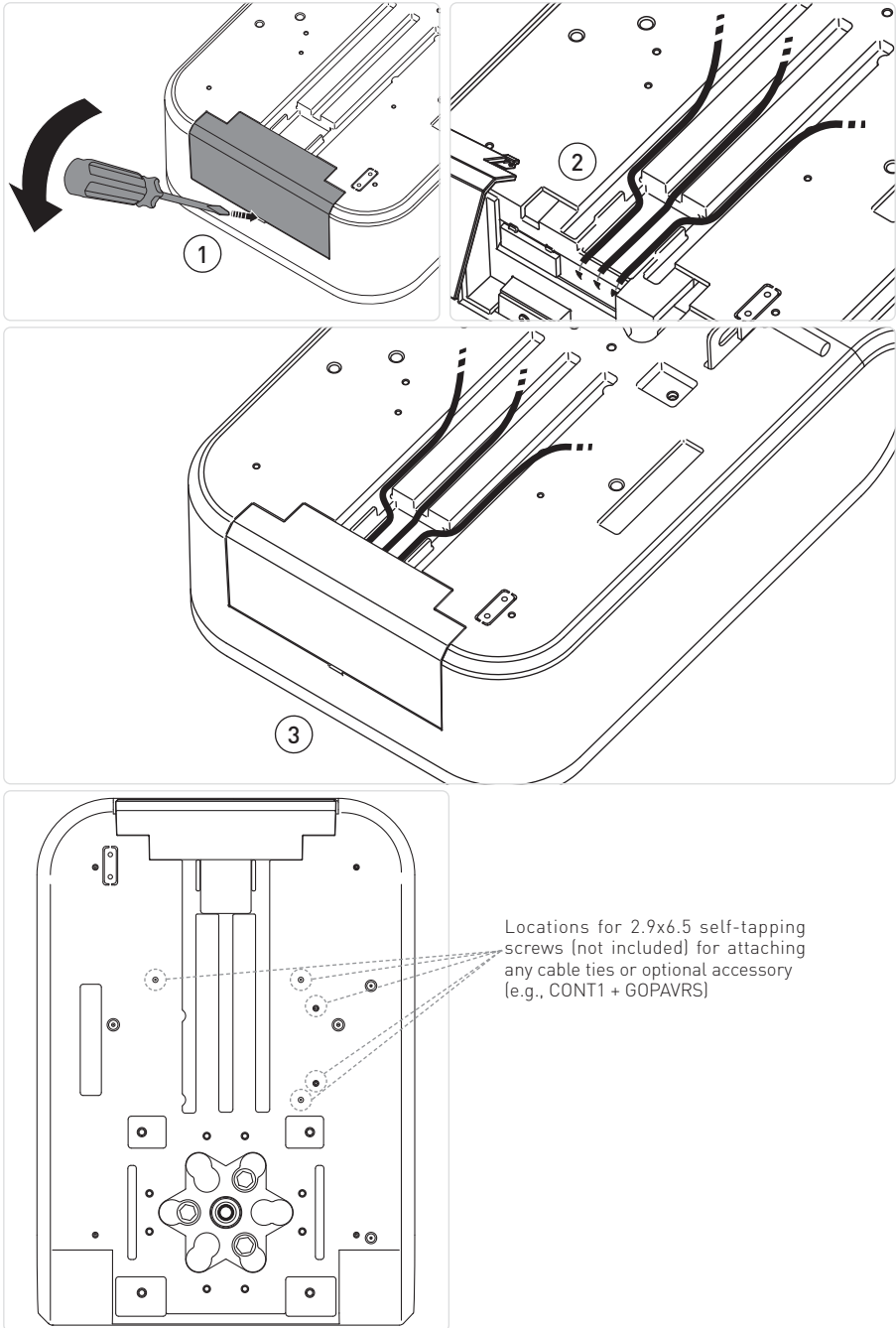

10. Electrical connections

Installation, electrical connections and adjustments must be performed by qualified personnel, in accordance with Good Working Methods and in compliance with the current regulations.

The automation must be installed in compliance with Standards EN12453, EN12445 and EN12635.

The safety devices must be working properly.

Garages without a second entrance must be equipped with an external emergency release device (to be ordered separately).

If there is a pedestrian door incorporated into the garage door, it must be equipped with a safety device that prevents it being activated when the garage door is open. This safety device must be connected to the EMERGENCY STOP.

 Before making the electrical connection, check that the data on the nameplate match those on the power supply network. Provide an omnipolar switch/disconnector on the power supply network with a contact opening distance of 3 mm or more. Ensure the presence of a suitable residual current and overvoltage protection device upstream of the electrical system.

Secure the cable by means of the cable clamp and only unsheathe it at the terminal.

Connections to the electrical distribution network and any other low-voltage conductors (230 V), in the section outside the automation system, must be made with corrugated pipes that are independent and separate from the path of connections to the control and safety devices (SELV= Safety Extra Low Voltage). Make sure there are no sharp edges that could damage the power cord.

 Ensure that the mains connection cables, any other low-voltage cables (230 V), and safety extra-low voltage safety accessory connection cables in the portion located inside the product are kept well separated from the gear motor body.

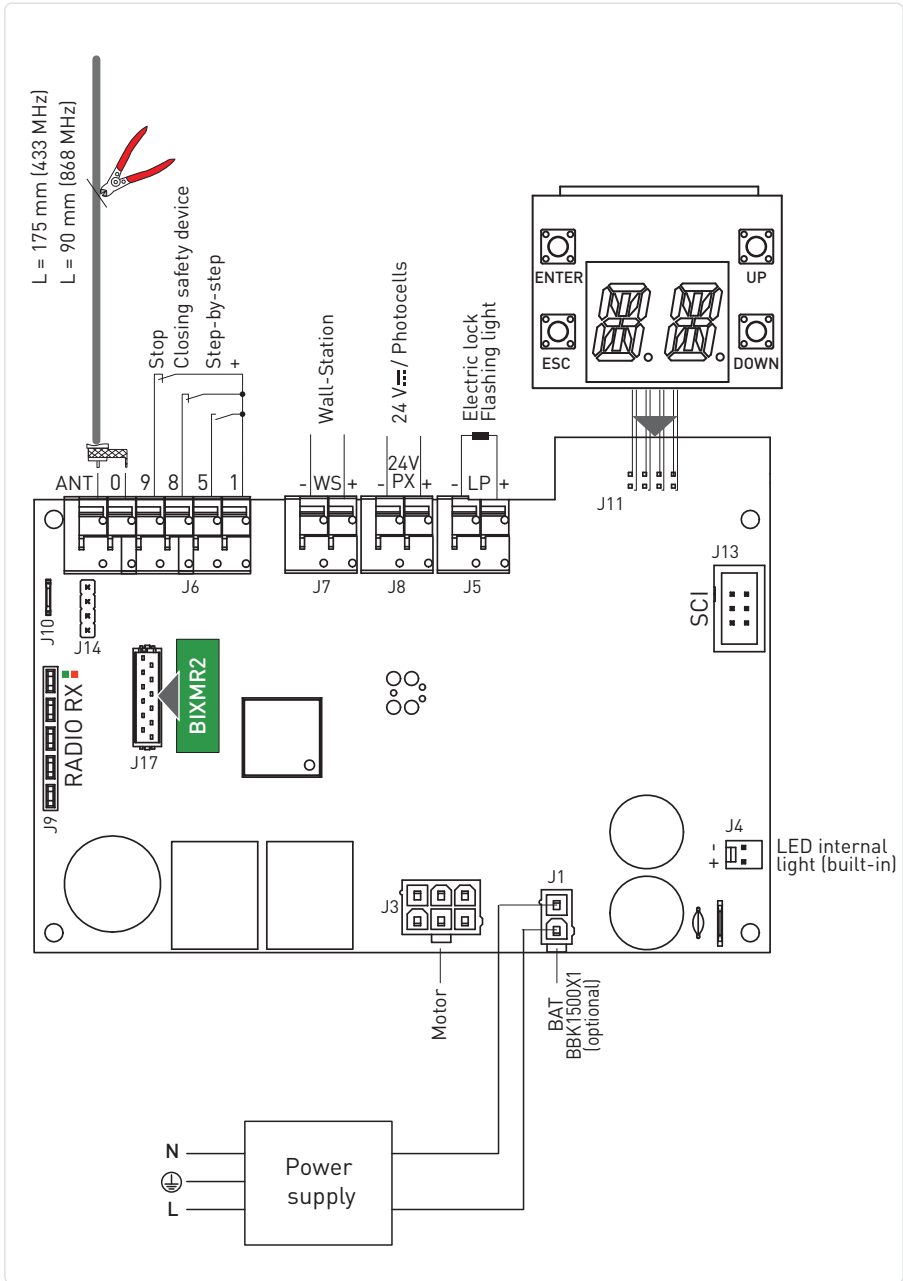

10.1 LCU60E electronic board

The figure shows the LCU60E electronic board and its connectors for connection to the power supply, motor and accessories.







IP2433EN

10.2 Reports







LED Red 	LED Green 	Description
off	off	Card off or not working.
1 Blink every second	off	LCU card on and working. RCB (radio/BLE/WiFi) card absent or not working
off	1 Blink every second	LCU card on and working. RCB50 (radio) board present and functioning
off	2 Blinks every second	LCU card on and working. RCB100 (radio/BLE) card present and functioning
off	3 Blinks every second	LCU card on and functioning. RCB201 (WiFi) card on SCI present and functioning
off	4 Blinks every second	LCU card on and functioning. RCB50 (radio) + RCB201 (WiFi) card present and functioning
off	5 Blinks every second	LCU card on and functioning. RCB100 (radio/BLE) + RCB201 (WiFi) card present and functioning

11. Commands

Function		Command	Description
NO	STEP-BY-STEP	1  5	When selecting IO → TS → FS , the closure of the contact NO activates a sequential opening or closing operation: opening-stop-closing-opening. The "opening-stop-closing-opening" sequence can be changed to "opening-stop-closing-stop-opening" by selecting OM → PP .
	OPENING		With IO → TS → FB selection, closing the contact activates the opening maneuver
NC	CLOSING SAFETY DEVICE	1  8	The opening of the NC contact triggers a reversal of the movement (reopening) during the closing operation, and the flashing of the courtesy light. After the 3 rd consecutive reversal movement, the automatic closure is disabled (if active). The reversal contact is used by the contacts of the 4 wire photo-cells and safety devices to signal the detection of an obstacle to the LCU60E board.
NC	STOP	1  9	The opening of the safety contact causes the current operation to stop. If IO → RG → GP , automatic closure is disabled when terminals 1-9 recloses. If IO → RG → GT , automatic closure remains enabled when terminals 1-9 recloses.

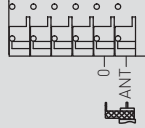
 **NOTE:** the flashing light makes a blink

12. Outputs and accessories

Function	Output	Value of accessories	Description
Accessories power supply		24 V DC / 0.3 A max 2 s 24 V DC / 0.15 A continuous	Accessory power output
Integrated led light		1750 lm	The internal LED light is connected to the board via connector J4. On AIR1000B it is possible to change the built-in LED light to the 3500 lms LED light (optional, see section 20.2) WARNING: An external third-party light cannot be connected on terminal J4.
Configurable output		12 V - 24 V~ 3 A max for 3 s 1 A continuous	Output LP factory configured as flashing light ON-OFF LP → 03 . It is possible to select preflashing settings from the 0H → 40 and/or 0H → 40 menu. To change the operation mode of the LP output refer to the 10 → LP selection.
Radio antenna			When using the standard antenna, the following measurements are recommended: 433 MHz (175 mm) - 868 MHz (90 mm). Use a RG-58 type coaxial cable (50 Ω) to connect an external antenna (ref. GOL148REA).
Module radio receiver			RCB100E radio receiver module (standard) configurable from control panel: - 433.92 MHz (RD → FG → 43) - default - 868.35 MHz (RD → FG → 86) RCB50E compatible radio receiver module (optional) WARNING: The insertion and extraction of the receiver module must be done by paying attention to the direction of positioning and in the absence of power.
Module memory remote controls		BIXMR2	Allows operation configurations to be saved using the BF → 5F function. Saved configurations can be recalled using the BF → RC function. The memory module enables the storage of radio controls. In case of electronic panel replacement, the memory module in use can be inserted into the new control panel. WARNING: The insertion and extraction of the receiver module must be done by paying attention to the direction of positioning and in the absence of power.
DC power supply		DC power supply	Power supply: 36 V DC. Without line voltage present, in battery operation mode: 24 V DC. With line voltage present the batteries are kept charged. With no line voltage present, the switchboard is powered by the batteries until the line is restored or until the battery voltage drops below the safety threshold. In the last case, the electronic control panel shuts down. NOTE: (The operating temperature of rechargeable batteries is between +0°C and 40°C. To check the voltage level of the batteries refer to menu BF → BL .

12.1 Wiring the accessories

12.1.1 4-wire photocells (ref. LIN2, AXP2, LAB4)

The photocells can be connected to the LCU60E board as described in the figure below
To activate the photocells set **IO** → **38** → **PH**.

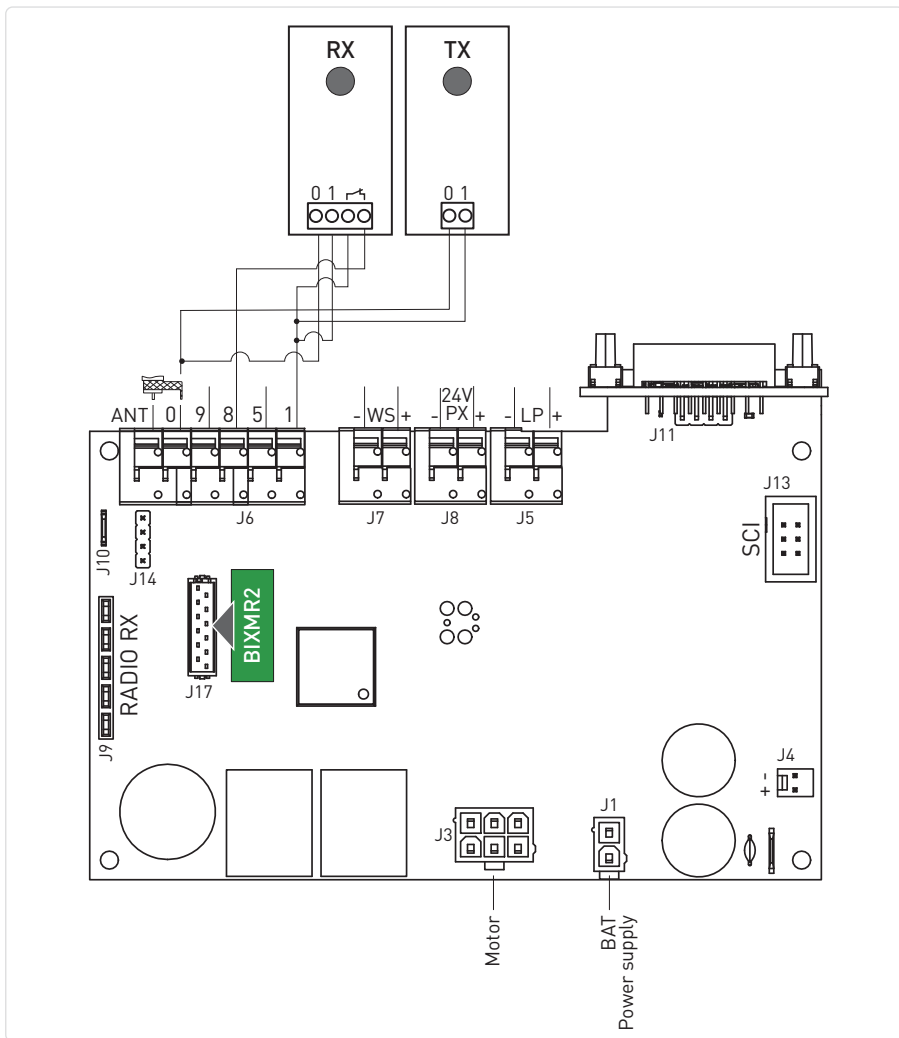

For complete instructions see manual:



LIN2



AXP2



LAB4

12.1.2 Two-wire photocells with Autotest (ref. LIN3)

Photocells (ref. LIN3) can be connected to the LCU60E board as described in the following figure. To activate the photocells, set **IO** → **BB** → **P2**.

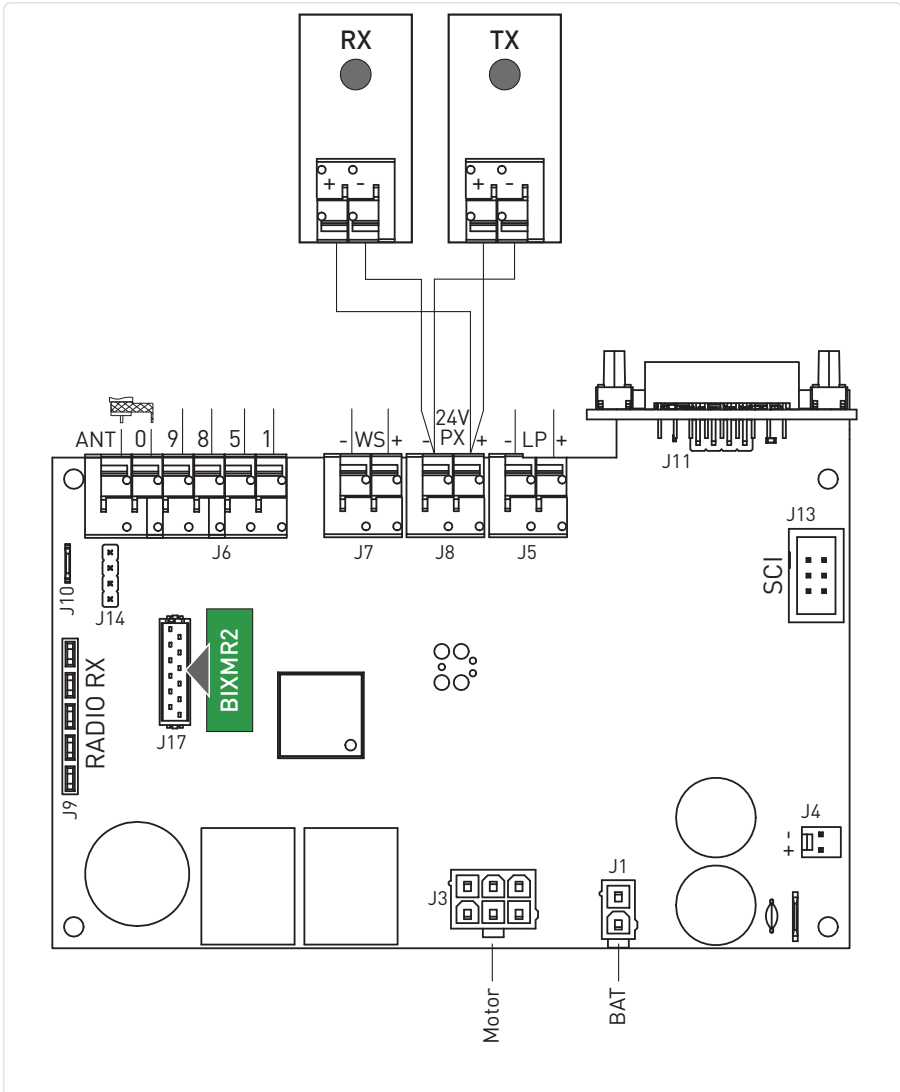

For complete instructions see manual:



LIN3

12.1.3 Radio system GOPAVR-GOPAVT for safety edges with autotest

Active safety ribs can be connected to the LCU60E board through the GOPAVR-GOPAVT two-way radio transmission system as described in the figure below.

To use GOPAVR-GOPAVT set up **10** → **38** → **54**.

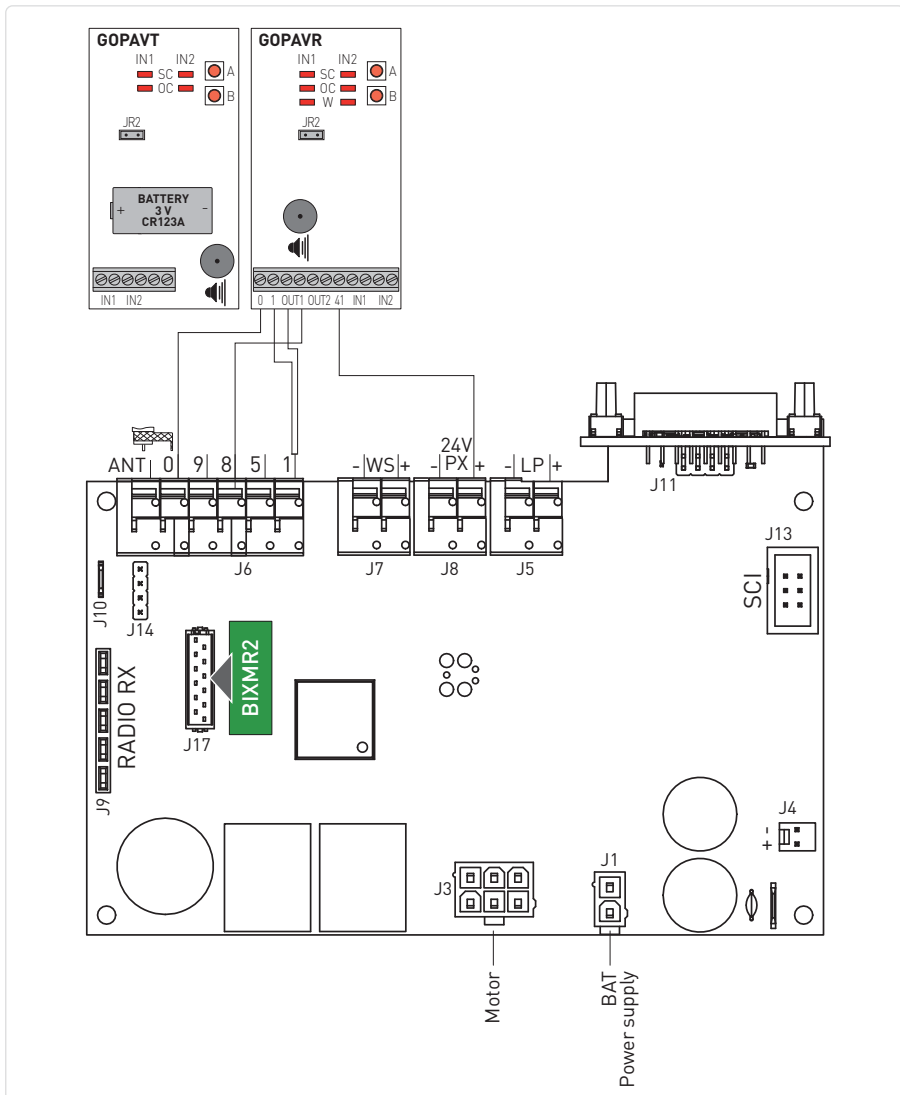

For complete instructions see manual:



GOPAV

12.1.4 GOPAVRS + CONT1 radio transmission system with self-test

Active safety ribs can be connected to the LCU60E board by the two-way radio transmission system GOPAVRS engaged in CONT1 as described in the following figure.

To use GOPAVRS + CONT1 set: **10** → **38** → **54**.

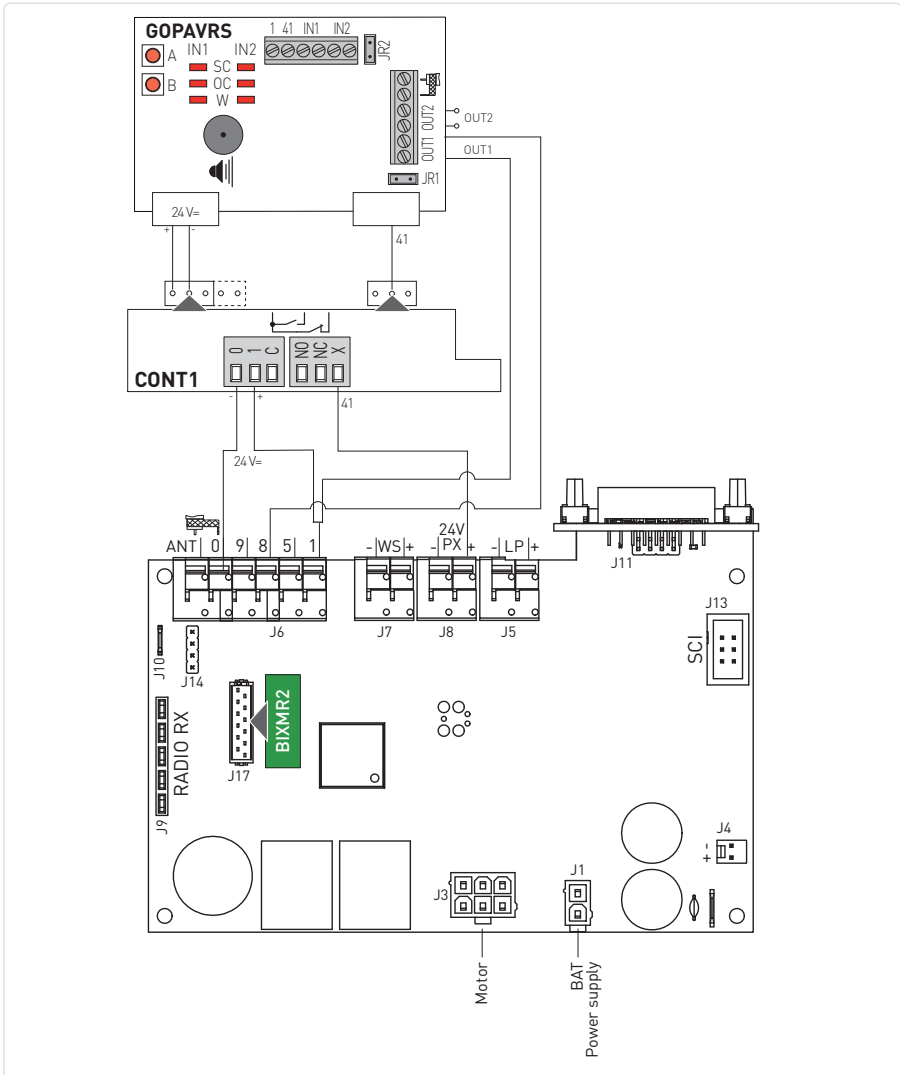

For complete instructions see manual:



CONT1



GOPAVRS

12.1.5 GOPAVR-VT radio transmission system + 2-wire photocells with self test
 Active safety edges can be connected to the LCU60E board thanks to the GOPAVR-VT two-way
 radio transmission system as described in the following figure.
 In case you also want to install photocells with self-test, you need to use LIN3 and set **10** → **18**
 → **P5**.

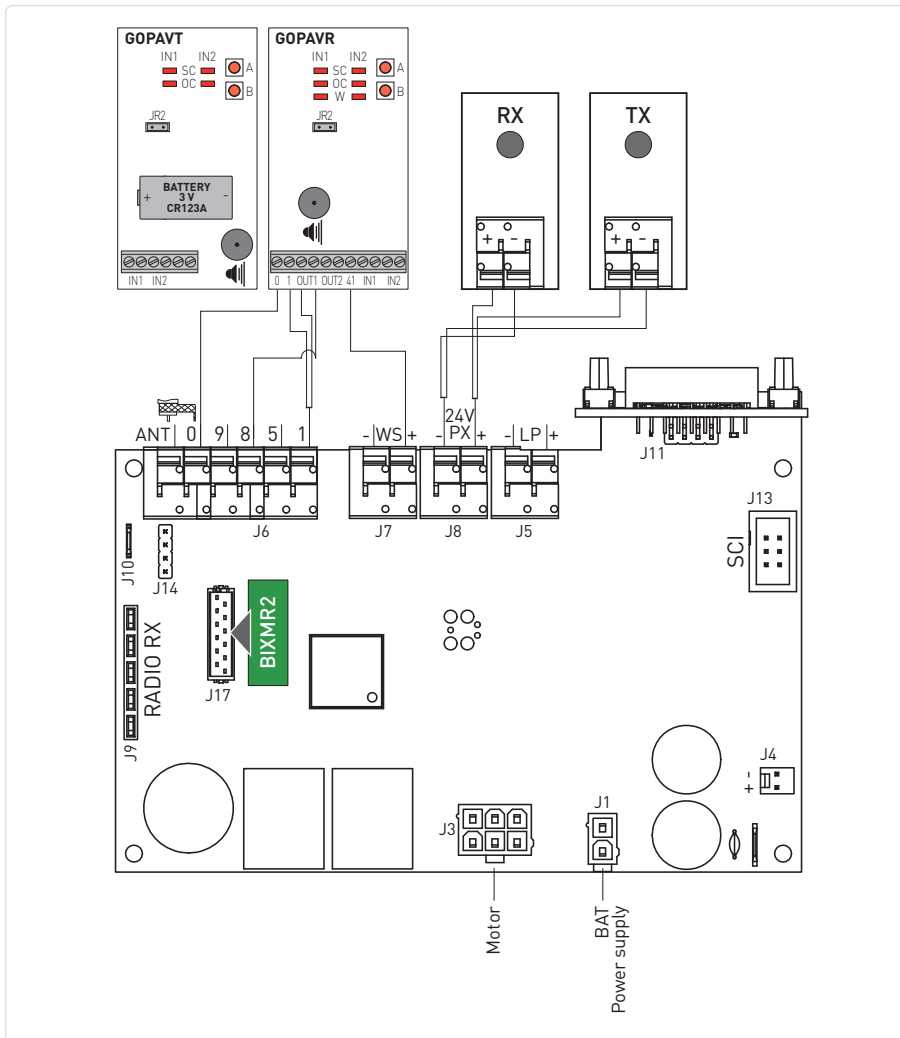

For complete instructions see manual:



CONT1



GOPAV



LIN3

12.1.6 Wall Station (ref. WS3)

The Wall Station accessory can be connected to the LCU60E board using the -WS+ terminal. To activate the Wall Station set **IO** → **WS** → **ON**.

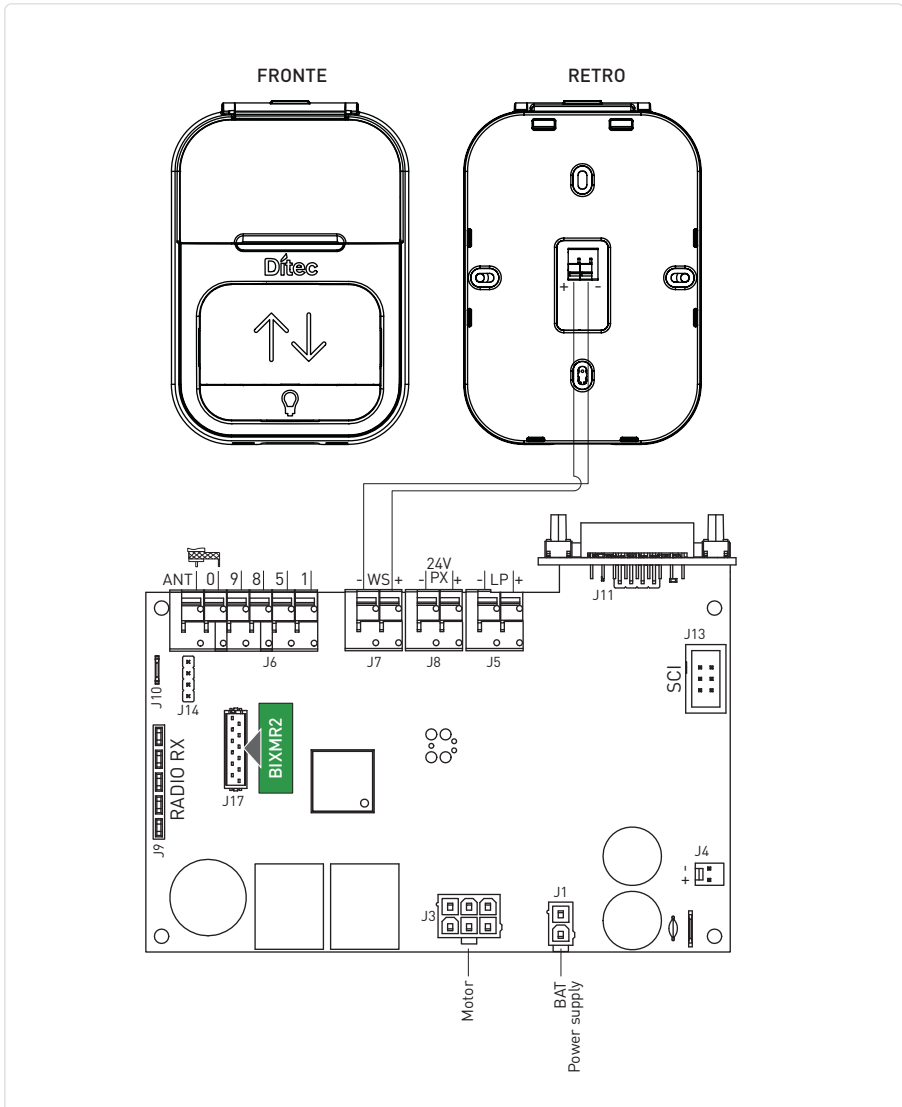

For complete instructions see manual:



WS3

12.1.7 Battery (ref. BBK1500X1)

The figure shows the power connections of the LCU60E board. Power supply and 20-cell Ni-MH 1500 mAh battery pack are connected to the LCU60E via the CHARGER board.

When the battery pack is not present, the power supply is directly connected to the LCU60E board.

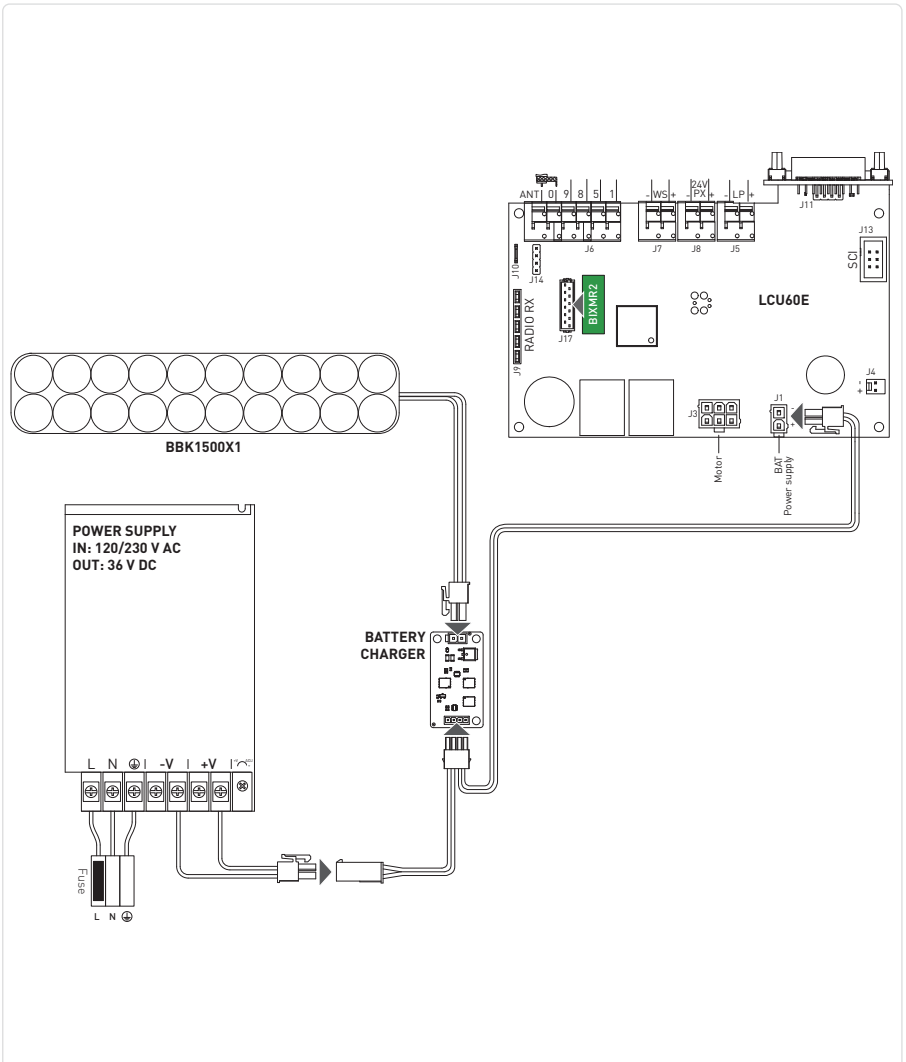





For complete instructions see manual:





BBK1500X1

13. Navigation buttons

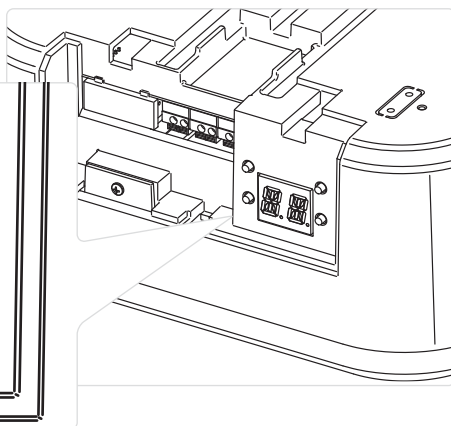
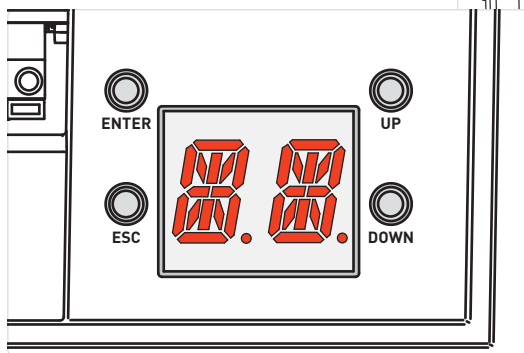
Display controls	
Command	Description
 UP	Navigation button UP
 DOWN	Navigation button DOWN
 ENTER	Menu button / confirm
 ESC	Menu button / exit



Status messages:

STEP	Display	Description
A		Door fully OPEN
B		Door between the two end stop positions
C		Door fully CLOSED

While the door is OPENING, the display visualizes in sequence:





While the door is CLOSING, the display visualizes in sequence:



The procedures and adjustments can only be carried out when the display is in mode:



A	
B	
C	

14. Self-learning of the stroke



WARNING 1: when a stroke self-learning operation is carried out, be sure that there is no obstacle on the run (e.g., execute a manual open/close operation of the garage door).





ATTENZIONE 2: In case of alarm or intervention of a protection (in case of photocells installed and configured via parameter **08**) the learning procedure will be interrupted and the alarm code will be shown on the display (in case of intervention of a photocell **18** will be shown). Restart the learning procedure by pressing  the system will return to **04**.



NOTE 1: If the procedure is in progress (step **03** or over) and you want interrupt it, press . The motor will stop and the learning restarts from the step **04**.

NOTE 2: in case you want have access to menu to change some parameters value you must exit from learning procedure pressing  key for few seconds till the display visualizes .



Once the setting is complete, it is possible to return to the self-learning procedure by pressing  repeatedly until you exit the menu and return to **04**. If it is not possible to return to **04**, press the  +  pbuttons simultaneously for about 4 seconds to perform a reset of the learning procedure

Self-learning procedure

1. Turn on the power supply and set the open position.



- The display flashes **04**.
- The courtesy light flashes 4 times during operation **04**.
- Press and hold the **UP** button. The door will open.
- Release the button when the required opening position is reached.
- Use the **UP** and **DOWN** buttons to correct the position if necessary.

2. Press the **ENTER** button. Self-learning operation start



- The automation stores the opening position and begins a closing operation.
- The display flashes **03**.
- Integrated LED light flashes 3 times.
- When the door reaches the closed position, the display flashes **02**. The courtesy light flashes twice.
- The automation opens automatically as far as the open position. The display flashes **01**. The courtesy light flashes once.
- The automation automatically recloses as far as the closed position, the display visualizes **00** and the door reopens.
- The lamp does not flash.

If the garage door stops before reaching the closed position, this could be due to an obstacle detected during the learning stroke. Stop the procedure by pressing the **ESC** key to avoid incorrect acquisition. Check for any physical obstacles (also check the sliding friction) and repeat the procedure. If necessary, change the thrust values via parameter **R2**

3. The self-learning procedure is complete when the door is fully open, and the courtesy light is ON.

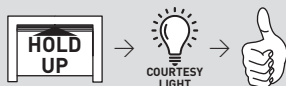

15. Memorizing / Deleting remote controls

15.1 Memorizing remote controls

Quick memorization:



Memorization from menu:

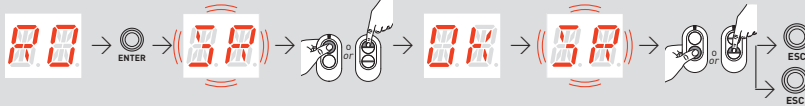

- Quick storage: press the and buttons simultaneously for about 2 seconds, flashing appears on the display and you can associate the desired buttons.
- Storage from menu: press or to scroll through menus. Select , press () starts flashing and you can associate the desired buttons.
- Once () is displayed, starts flashing again and the next button can be associated.
- Press to exit.
- Once you finish to associate buttons if you want set a specific function to the buttons you have to go in the menu () and acting on the parameters , , , otherwise default functions will be associated.

NOTE: if only one button/channel is memorized then the associate function will be automatic set to **OPEN** or **STEP-by-STEP** depending by the value of → parameter.

15.2 Deleting remote controls

The remote control can be deleted acting on the specific parameter in the menu and follow the instructions:

Deletion of a single remote control

See the parameter:



Deletion of all remote controls

See the parameter:



16. Using of the menus

16.1 Switching the display ON and OFF

The procedure to switch ON the display is as follows:

MAIN LEVEL

- The display indicates by default the status of the door
- Press the key
- The display functioning check starts
- The main level menu is displayed

The procedure to switch OFF the display is as follows:

MAIN LEVEL

After 60 seconds of inactivity, you exit the configuration menu and the display indicates the status of the door

16.2 Navigation keys

VALUE LEVEL PARAMETER MAIN LEVEL PRINCIPALE

PARAMETER LEVEL

- Press or to scroll through the menus.
- Press to go in **PARAMETER LEVEL**.
- Press to exit from a sub-menu.



PARAMETER LEVEL

- Press or to scroll through the parameters inside the specific sub-menu.
- To set a parameter, select the desired **VALUE** and press for 2 seconds to save.

16.3 Shortcuts

16.3.1 Calibration reset





By pressing the  and  buttons simultaneously, causes the display to flash **RE**, first slowly and then faster. Continue to hold (for about more than 4 seconds) until the system performs a reset and the display shows **00** (all calibration run values have been cleared). Now you can release the keys, the system is ready to perform a new learning procedure

i **NOTE:** the stored calibration can also be deleted by acting on the appropriate parameter in the **RR** → **RR** menu

16.3.2 System restart





Pressing the  and  keys simultaneously will cause the display to flash **RS**, first slowly and then faster. Continue to hold (for about more than 4 seconds) until the system performs a restart.

i **NOTE:** it is only a system restart, calibration values, parameter setting and transmitters are not deleted.

16.3.3 Radio remote control storage via control panel





If you press the  and  buttons simultaneously for more than 4 seconds, the display shows **SR**, then release the buttons. When the display starts flashing **SR**, you can associate the desired buttons.

i **NOTE:** storage of remote controls can also be performed by acting on the appropriate parameter in the menu

16.3.4 Wi-fi reset







If you press  and  keys simultaneously, the display will flash **RW** first slowly, then faster. When the display stops flashing and **RW** is fixed, the WiFi device will be reset, release the keys.











17. Parameters LCU60E







17.1 Main level menu

Display	Description
	Frequent use The menu allows to manage the most commonly used parameters to customize the functionalities of the automation

Complete menu		Operation Mode The menu allows to manage all the parameters used for operation modes of the automation (type of automation installed, predefined settings, automatic closure, etc.)
		Run Adjustment The menu allows to adjust all the run parameters (opening/closure speed, slowdown positions, obstacle thrust sensibility etc.)
		Input/Output Configuration The menu allows to configure the inputs/outputs functionalities of the automation (selection of devices connected to the terminals, photocells, flashing light/electro-lock setting, etc.)
		Radio and Connectivity Operations The menu is used to manage all parameters for the radio/wireless functions of the control panel
		Diagnostic Functions The menu allows to manage all other parameters used for additional services (diagnostic counters, FW updating, energy saving, etc.)

17.2 Frequent use menu map

MAIN LEVEL	
	FU - Frequent Use
PARAMETER LEVEL	
	AS - Selection of door type
	DM - Open direction
	EP - Setting encrypted radio transmission protocol (AES 128bit and PROTECTED mode)
	SR - Remote control storage
	RM - Radio receiver operation
	T5 - Terminal 5 operation mode
	AC - Automatic closure enabling
	TC - Setting of automatic closing time [s]
	RP - Adjustment of partial opening measurement [%]























	TP - Setting of automatic closing time after partial opening [s]
	R1 - Adjustment of thrust on obstacles in the opening
	R2 - Adjusting thrust on closing obstacles
	VA - Opening speed [cm/s]
	VC - Closing speed [cm/s]
	R9 - Configuration of input 1-9
	D8 - Selection of device connected to terminals 1-8

















IP2433EN

17.3 Complete menu map

MAIN LEVEL	
0M	OM - Operation Mode
	PARAMETER LEVEL
AS	AS - Selection of door type
DM	DM - Open direction
AC	AC - Automatic closure enabling
0M	TC - Setting of automatic closing time [s]
RP	RP - Adjustment of partial opening measurement [%]
TP	TP - Setting of automatic closing time after partial opening [s]
PP	PP - Setting of step-by-step sequence
TS	TS - Renewal of automatic closing time after release of safety device [%]
0M	WO - Setting of pre-flashing time on opening [s]
WC	WC - Setting of pre-flashing time on closing [s]
PK	PK - Parking assistance
RA	RA - Run Adjustment
	PARAMETER LEVEL
VA	VA - Opening speed [cm/s]
VC	VC - Closing speed [cm/s]
R1	R1 - Adjustment of thrust on obstacles during opening
RR	R2 - Adjustment of thrust on obstacles during closing
OB	OB - Adjustment of deceleration distance during opening [cm]
CB	CB - Adjustment of deceleration distance during closing [cm]
PC	PC - Adjustment of approach speed during opening [cm/s]
DC	DC - Setting of disengagement on stop during closing [mm]
VR	VR - Setting acquisition speed

TA	TA - Adjusting time acceleration in opening
TQ	TQ - Adjusting time acceleration in closing
TD	TD - Adjusting deceleration time in opening
TU	TU - Adjusting deceleration time in closing
DC	DC - Setting of disengagement on stop during closure [mm]
ST	ST - Adjusting the inrush time
DT	DT - Adjusting obstacle recognition time
RR	RR - Resetting run calibration values
IO	IO - Input/Output Configuration
	PARAMETER LEVEL
R9	R9 - Configuration of input 1-9
T5	T5 - Terminal 5 operation mode
D8	D8 - Selection of device connected to terminals 1-8
LP	LP - Function of output +LP-
LU	LU - Time to turn on the courtesy light [s]
LG	LG - Switch-on time for independently commanded courtesy light [min]
BR	BR - Brightness level of the courtesy light
LR	LR - Electric lock release time [s]
ES	ES - Energy-saving
WS	WS - Setting of Wall Station device
BZ	BZ - Buzzer enable/disable

 R0 - Radio and Connectivity Operations	
PARAMETER LEVEL	
	EP - Setting encrypted messages
	SR - Remote control storage
	RM - Radio receiver operation
	TX - Visualization of counter showing remote controls stored
	MU - Setting of the maximum number of remote controls that can be stored in the memory
	ER - Deletion of a single remote control
	EA - Total memory deletion
	C1, C2, C3, C4 - Selection of CH1, CH2, CH3, CH4 function of stored remote control
	FQ - Radio frequency selection
	VL - enable/disable vacation mode
	BT - Enabling/disabling Bluetooth®
	WF - Setting of WiFi functionality
	WQ - Request to restart the connected WiFi device (in particular Apple HomeKit)
	MA - Deletion of Mobile App control permissions
 DF - Diagnostic Functions	
PARAMETER LEVEL	
	AI - Automation model ID Info
	CU - Visualization of the firmware version on the control panel
	UP - Firmware update
	AL - Alarm counter
	UP - Alarm log
	AR - Alarm reset
	CV - Display of total operations counter

	CP - Display of partial operations counter
	ZP - Reset of partial operations counter
	CA - Setting the maintenance alarm [factory setting - alarm deactivated: 0.0 00. 00]
	OA - Selecting maintenance alarm display mode
	CH - Display of power supply hour counter
	BH - Visualization of counter for power supply hours via battery
	SV - Saving user configuration on control panel storage module
	RC - Configuration loading
	RL - Loading of last configuration set
	EU - Erasing of user configurations and last configuration set in the storage module
	IM - Motor current visualization
	BL - Visualization of Battery voltage level
	EL - Efficiency level of the automation
	EN - Enable force detection test according EN 13241-1
	UB - Door unbalanced level
	RD - Resetting of factory settings

17.4 Frequent use parameters description



FU - Frequent Use

The menu allows to manage the most commonly used parameters to customize the functionalities of the automation.

Parameter	Description	Selections available																																
	AS - Selection of automation door installed <ul style="list-style-type: none"> SD: sectional door LS: side sectional door BS: up-and-over door with soft start 																																	
	NOTE: NOTE: If the value has been changed, the previously acquired stroke parameters will be deleted and the operator will wait for a new self-learning maneuver . See section 14																																	
	<table border="1"> <thead> <tr> <th>AS</th> <th>R1-R2</th> <th>VA</th> <th>OB</th> <th>TA</th> <th>TQ</th> <th>TD</th> <th>TU</th> </tr> </thead> <tbody> <tr> <td>SD</td> <td>20</td> <td>20</td> <td>20</td> <td>2.0</td> <td>2.0</td> <td>30</td> <td>20</td> </tr> <tr> <td>LS</td> <td>20</td> <td>20</td> <td>20</td> <td>2.0</td> <td>2.0</td> <td>30</td> <td>20</td> </tr> <tr> <td>BS</td> <td>30</td> <td>15</td> <td>40</td> <td>2.5</td> <td>2.5</td> <td>60</td> <td>40</td> </tr> </tbody> </table>	AS	R1-R2	VA	OB	TA	TQ	TD	TU	SD	20	20	20	2.0	2.0	30	20	LS	20	20	20	2.0	2.0	30	20	BS	30	15	40	2.5	2.5	60	40	
AS	R1-R2	VA	OB	TA	TQ	TD	TU																											
SD	20	20	20	2.0	2.0	30	20																											
LS	20	20	20	2.0	2.0	30	20																											
BS	30	15	40	2.5	2.5	60	40																											
	DM - Open direction <ul style="list-style-type: none"> 00: opening direction with TOP guides and TSRFK retrofit kit 01: standard opening direction with AIR guides 																																	
	NOTE: NOTE: If the value has been changed, the previously acquired stroke parameters will be deleted and the operator will wait for a new self-learning maneuver . See section 14																																	
	EP - Setting up encrypted radio transmission protocol (AES 128bit and PROTECTED mode)																																	
	If the possibility to receive coded messages is enabled, the control panel will be compatible with remote controls of the "CRYPTED or PROTECTED mode" type. <ul style="list-style-type: none"> 0N: enabled 0F: disabled 																																	
	SR - Remote control storage																																	
	<p>By pressing starts flashing and it is possible to associate the desired buttons. After is displayed, flashes again on the display and it is possible to associate the next button. To exit, press or for 2 seconds and move on to the next item.</p> NOTE: if the display shows flashing, the remote control may already be stored.																																	
	RM - Radio receiver operation <p>This is the function associated to radio command when only one channel is stored (independently which one is)</p> <ul style="list-style-type: none"> 1-5 - Step-by-step 1-3 - Opening 																																	
	T5 - Terminal 5 operation mode <p>This parameter is associated to the functionality of the terminal 1-5</p> <ul style="list-style-type: none"> 1-5 - Step-by-step 1-3 - Opening 																																	
	AC - Automatic closure enabling <ul style="list-style-type: none"> 0F - Disabled 0N - Enabled 																																	
	TC - Setting of automatic closing time [s] <p>It is set with different intervals of sensitivity:</p> <ul style="list-style-type: none"> from 0" to 59" with intervals of 1 second from 1'0 to 1'5 with intervals of 10 seconds <p>For each interval, the display visualizes:</p> <ul style="list-style-type: none"> → 1 minute and 10 seconds → 1 minute and 50 seconds from 2' to 4' with intervals of 1 minute 																																	

	RP - Adjustment of partial opening measurement [%] This parameter adjusts the percentage of partial opening in relation to the total opening of the automation. <ul style="list-style-type: none"> from 5% to 99 % with intervals of 1 % 	
	TP - Setting of automatic closing time after partial opening [s] It is set with different intervals of sensitivity: <ul style="list-style-type: none"> from 0" to 59" with intervals of 1 second from 1'0 to 1'5 with intervals of 10 seconds For each interval, the display visualizes: <ul style="list-style-type: none"> - 01 → 1 minute and 10 seconds - ... - 05 → 1 minute and 50 seconds from 2' to 4' with intervals of 1 minute 	
	R1 - Adjustment of thrust on obstacles and motor current during opening [%] When the thrust exceeds the threshold, the system detects an obstacle and the movement is stopped. <ul style="list-style-type: none"> 00 - Minimum thrust (minimum current delta for obstacle detection) 99 - Maximum thrust (maximum current delta for obstacle detection) The threshold is calculated dynamically like a delta on the motor current measured during the opening stroke.	
	R2 - Adjustment of thrust on obstacles and motor current during closing [%] When the thrust exceeds the threshold, the system detects an obstacle, and the movement is inverted. It has divided in two ranges with a different sensibility to give maximum flexibility according to needs: <ul style="list-style-type: none"> from 00 to 40 - Soft thrust from 41 to 99 - Strong thrust The threshold is calculated dynamically like a delta on the motor current measured during the closing stroke. <div style="background-color: yellow; padding: 5px; margin-top: 10px;"> <p>⚠ WARNING: The default value ensures the closing thrust force values return within the limits established by Standard EN12453. Set different values to have stronger thrust force but in this case be aware that it is not guaranteed the fulfillment of limits by Standard EN12453. This operation must be carried out by qualified personnel.</p> </div>	
	VA - Opening speed [cm/s] <ul style="list-style-type: none"> from 8 to 22 cm/s with intervals of 1 cm/s 	
	VC - Closing speed [cm/s] <ul style="list-style-type: none"> from 8 to 22 cm/s with intervals of 1 cm/s <div style="background-color: yellow; padding: 5px; margin-top: 10px;"> <p>⚠ WARNING: the default value ensures the closing thrust force values return within the limits established by Standard EN12453. In case a higher closing speed is set it is not guaranteed the fulfillment of limits by Standard EN12453.</p> </div>	
	R9 - Configuration of input 1-9 <ul style="list-style-type: none"> NO: disabled. 9P: open state of the input triggers permanent stop (default). 9T: open state of the input triggers temporary stop. Once contact closes, automatic closure time (if enabled) is activated. 	
	D8 - Selection of the device connected to terminals 1-8 <ul style="list-style-type: none"> NO - None PH - LIN2 photocells SP41 - Photocells with safety test SE - Safety edge S41 - Safety edge with safety test P2 - LIN3 photocells with auto test PE - Safety edge + LIN3 photocells (self-test) PS - Safety edge with safety test + LIN3 photocells with self test 	

17.5 Complete menu - parameters description



OM - Operation Mode

The menu allows to manage all the parameters used for operation modes of the automation (type of automation installed, predefined settings, automatic closure, etc.)

Parameter	Description	Selections available																																
	AS - Selection of automation door installed <ul style="list-style-type: none"> SD: sectional door LS: side sectional door BS: up-and-over door with soft start 	 																																
	<p>NOTE: NOTE: If the value has been changed, the previously acquired stroke parameters will be deleted and the operator will wait for a new self-learning maneuver . See section 14</p>																																	
	<table border="1"> <thead> <tr> <th>AS</th> <th>R1-R2</th> <th>VA</th> <th>OB</th> <th>TA</th> <th>TQ</th> <th>TD</th> <th>TU</th> </tr> </thead> <tbody> <tr> <td>SD</td> <td>20</td> <td>20</td> <td>20</td> <td>2.0</td> <td>2.0</td> <td>30</td> <td>20</td> </tr> <tr> <td>LS</td> <td>20</td> <td>20</td> <td>20</td> <td>2.0</td> <td>2.0</td> <td>30</td> <td>20</td> </tr> <tr> <td>TD</td> <td>30</td> <td>15</td> <td>40</td> <td>2.5</td> <td>2.5</td> <td>60</td> <td>40</td> </tr> </tbody> </table>	AS	R1-R2	VA	OB	TA	TQ	TD	TU	SD	20	20	20	2.0	2.0	30	20	LS	20	20	20	2.0	2.0	30	20	TD	30	15	40	2.5	2.5	60	40	
AS	R1-R2	VA	OB	TA	TQ	TD	TU																											
SD	20	20	20	2.0	2.0	30	20																											
LS	20	20	20	2.0	2.0	30	20																											
TD	30	15	40	2.5	2.5	60	40																											

	DM - Open direction <ul style="list-style-type: none"> 00: opening direction with TOP track system and TSRFK retrofit kit 01: standard opening direction with AIR track system 	
	<p>NOTE: NOTE: If the value has been changed, the previously acquired stroke parameters will be deleted and the operator will wait for a new self-learning maneuver . See section 14</p>	

	AC - Automatic closure enabling <ul style="list-style-type: none"> OF - Disabled ON - Enabled 	
--	--	--

	TC - Setting of automatic closing time [s] It is set with different intervals of sensitivity:
	<ul style="list-style-type: none"> from 0" to 59" with intervals of 1 second from 1'0 to 1'5 with intervals of 10 seconds For each interval, the display visualizes: - → 1 minute and 10 seconds - ... - → 1 minute and 50 seconds from 2' to 4' with intervals of 1 minute 	

	RP - Adjustment of partial opening measurement [%] This parameter adjusts the percentage of partial opening in relation to the total opening of the automation.	...
--	---	-----

	TP - Setting of automatic closing time after partial opening [s] It is set with different intervals of sensitivity.
	<ul style="list-style-type: none"> from 0" to 59" with intervals of 1 second from 1'0 to 1'5 with intervals of 10 seconds For each interval, the display visualizes: - → 1 minute and 10 seconds - ... - → 1 minute and 50 seconds from 2' to 4' with intervals of 1 minute 	

	PP - Setting of step-by-step sequence <ul style="list-style-type: none"> 00 - Opening-Stop-Closing-Opening 01 - Opening-Stop-Closing-Stop-Opening 	
--	--	--



TS - Setting of renewal of automatic closing time after photocells safety device release [%]

- from 0 to 99% with intervals of 1%.

The count begins with the door fully open, (and the closing operation is performed even with automatic closure (RC) disabled).

WARNING: automatic closure is not disabled on the third consecutive direction reversal.

E.g.:

- **TS** = 1"
- **TS** = 50%
- Renewal of automatic closing time= 30"



WO - Setting of pre-flashing time on opening [s]

Adjustment of the lead time for the switch-on of the flashing light and courtesy light, in relation to the start of the opening operation from a voluntary command.

- from 0" to 5" with intervals of 1 second



WC - Setting of pre-flashing time on closing [s]

Adjustment of the lead time for the switch-on of the flashing light and courtesy light in relation to the start of the closing operation from a voluntary command.

- from 0" to 5" with intervals of 1 second



PK - Parking assistance (only with photocells installed)

Once the door has opened and the car has passed through, the courtesy light flashes quickly 3 times when the photocells are disengaged to indicate that the door can be closed because the car is no longer in the passage opening.

- **ON** - Enabled
- **OF** - Disabled

NOTE: it is recommended to install internal photocells















































RA - Run Adjustment

The menu allows to adjust all the run parameters (opening/closure speed, slowdown positions, obstacle thrust sensibility etc.)

Parameter	Description	Selections available
	VA - Opening speed [cm/s] • from 8 to 22 cm/s with intervals of 1 cm/s	 [default value. Depends on AS setting]
	VC - Closing speed [cm/s] • from 8 to 22 cm/s with intervals of 1 cm/s WARNING: the default value ensures the closing thrust force values return within the limits established by Standard EN12453. In case a higher closing speed is set it is not guaranteed the fulfilment of limits by Standard EN12453.	
	R1 - Adjustment of thrust on obstacles and motor current during opening [%] When the thrust exceeds the threshold, the system detects an obstacle and the movement is stopped. 00 - Minimum thrust (minimum current delta for obstacle detection) 99 - Maximum thrust (maximum current delta for obstacle detection) The threshold is calculated dynamically like a delta on the motor current measured during the opening stroke.	
	R2 - Adjustment of thrust on obstacles and motor current during closing [%] When the thrust exceeds the threshold, the system detects an obstacle, and the movement is inverted. It has divided in two ranges with a different sensibility to give maximum flexibility according to needs: from 00 to 40 - Soft thrust from 41 to 99 - Strong thrust The threshold is calculated dynamically like a delta on the motor current measured during the closing stroke. WARNING: The default value ensures the closing thrust force values return within the limits established by Standard EN12453. Set different values to have stronger thrust force but in this case be aware that it is not guaranteed the fulfilment of limits by Standard EN12453. This operation must be carried out by qualified personnel.	
	OB - Adjustment of deceleration distance during opening [cm] Indicates the deceleration distance before reaching the maximum open position. • from 10 to 60 cm with intervals of 1 cm	 [default value. Depends on AS setting]
	P0 - Adjustment of approach speed in opening [cm/s]. It indicates the speed from the end of the deceleration ramp to the end of the opening stroke • from 5 to 15 cm/s with intervals of 1 cm/s	
	CB - Adjustment of deceleration distance during closing [cm] Indicates the deceleration distance before reaching the closing position. • from 20 to 60 cm with intervals of 1 cm	
	PC - Adjustment of approach speed during closing [cm/s] • from 5 to 15 cm/s with intervals of 1 cm/s WARNING: the default value ensures the closing thrust force values return within the limits established by Standard EN12453. In case a higher closing speed is set it is not guaranteed the fulfilment of limits by Standard EN12453.	
	VR - Setting of acquisition speed [cm/s] • from 5 to 15 cm/s with intervals of 1 cm/s	

		TA - Adjustment of acceleration time during opening [s] Regulates the slope of the acceleration ramp during opening • from 0.5 to 9.9 s with intervals of 0.1 s	 [default value. Depends on AS setting]
		TQ - Adjustment of acceleration time during closure [s] Regulates the slope of the acceleration ramp during closing • from 0.5 to 9.9 s with intervals of 0.1 s	 [default value. Depends on AS setting]
		TD - Adjustment of deceleration time during opening [%] Regulates the slope of the deceleration ramp during opening. • from 10 to 99 % with intervals of 1 %	 [default value. Depends on AS setting]
		TU - Adjustment of deceleration time during closure [%] Regulates the slope of the deceleration ramp during closing. • from 10 to 99 % with intervals of 1 %	 [default value. Depends on AS setting]
		DC - Setting of disengagement on stop during closure [mm] Regulates the distance of the disengagement on the mechanical closing stop. • 00 – Disabled • from 1 to 15 mm with intervals of 1 mm	
		ST - Adjusting the inrush time [s] • from 0.5 to 3.0 s with intervals of 1%	
		DT - Adjustment of obstacle recognition time [s/100] • from 10 to 60 s/100 with intervals of 1 s/100 i NOTE: the parameter is adjusted in hundredths of a second	
RR - Resetting run calibration values It permits to perform a new learning procedure.			

Parameter	Description	Selections available
	IO - Input/Output Configuration The menu allows to configure the inputs/outputs functionalities of the automation.	
	R9 - Configuration of input 1-9 <ul style="list-style-type: none"> • NO: disabled. • 9P: open state of the input triggers permanent stop (default). • 9T: open state of the input triggers temporary stop. Once contact closure, automatic closure time (if enabled) is activated. 	  
	T5 - Terminal 5 operation mode <ul style="list-style-type: none"> • 1-5 - Step-by-step • 1-3 - Opening 	 
	8 - Selection of the device connected to terminals 1-8 <ul style="list-style-type: none"> • NO - None • PH - LIN2 photocells • SP41 - Photocells with safety test • SE - Safety edge • S41 - Safety edge with safety test • P2 - LIN3 photocells with auto test • PE - Safety edge + LIN3 photocells (self-test) • PS - Safety edge with safety test + LIN3 photocells with self test 	       
	LP - Output function +LP- <ul style="list-style-type: none"> • 01 - Electric lock (activated for a time defined by parameter  • 03 - ON-OFF flashing light without oscillator (active when the motor is in action) • 04 - ON-OFF flashing LED without oscillator (active when the motor is in action) • 05 - ON for flashing LED with internal oscillator • 08 - Closed automation (activated with door fully closed) • 09 - Automation open (activated with door fully open) • 13 - Maintenance alarm • 14 - Signal for batteries almost discharged • 0N - Output always on 	        
	LU - Courtesy light supplementary time setting [s]. It is set with different sensitivity ranges. <ul style="list-style-type: none"> • NO - Disabled • from 01" to 59" with intervals of 1 second • from 1' to 2' with intervals of 10 seconds • from 2' to 4' with intervals of 1 minute • 0N - Permanently activated (deactivated by remote control or Wall Station) <p>i NOTE: The courtesy light comes on at the beginning of each operation and stays on at the end of the operation for the additional time selected.</p>	  ...   ...   ...  
	LG - Switch-on time for independently commanded courtesy light [min] <ul style="list-style-type: none"> • NO - Disabled • from 1' to 90' with intervals of 1 minute • 0N - Switched on and off with remote control or Wall-Station <p>i NOTE: the switching on of the light does not depend on the start of an operation but can be commanded separately using the remote-control.</p>	  ...  



R0 - Radio and Connectivity Operations

The menu is used to manage all parameters for the radio/wireless functions of the control panel

Parameter	Description	Selections available
	<p>EP - Setting up encrypted radio transmission messages (AES 128bit mode and protected mode) If the possibility to receive coded messages is enabled, the control panel will be compatible with remote controls of the "ENCRYPTED" type.</p>	 
	<p>SR - Remote control storage</p>  <p>By pressing   starts flashing and it is possible to associate the desired buttons. After  is displayed,  flashes again on the display and it is possible to associate the next button. To exit, press  or  for 2 seconds and move on to the next item.</p> <p>NOTE: if the display shows  flashing, the remote control may already be memorized.</p>	... x2, x3...
	<p>RM - Radio receiver operation</p> <ul style="list-style-type: none"> • 1-5 - Step-by-step • 1-3 - Opening <p>NOTE: this is the function associated to radio command when only one channel is stored (independently which one is).</p>	 
	<p>TX - Visualization of counter showing remote control stored</p> 	
	<p>MU - Setting of the maximum number of remote controls that can be stored in the memory You can store a maximum of 100 or 200 remote control codes.</p>  <p>• 20 - 200 remote controls that can be stored • 10 - 100 remote controls that can be stored</p> <p>WARNING: selecting  →  (200 remote controls), the configurations  and  saved with the  →  command will be lost. This also applies for the last configuration reloaded with . In addition, new configurations cannot be saved on  and .</p>	 
	<p>ER - Deletion of a single remote control</p> 	



	<p>EA - Total memory deletion</p> <p>It requires double confirm. Press for 2 seconds, release and press again for other 2 seconds.</p>	
 	<p>C1, C2, C3, C4 - Selection of CH1, CH2, CH3, CH4 function of stored remote control</p> <ul style="list-style-type: none"> • NO - No setting selected • 1-3 - Opening command • 1-4 - Closing command • 1-5 - Step-by-step command • P3 - Partial opening command • LG - Command to switch the courtesy light on/off • 1-9 - STOP command <p>If even just one (any) CH key of the remote control is stored, the opening or stepby- step command is implemented.</p> <p>i NOTE: the 1-3 (opening) and 1-5 (step-by-step) options are available as alternatives, and depend on the selection of RM.</p> <p>If 2-4 CH keys of a single remote control are stored, the functions matched in the factory with the CH keys are as follows:</p> <ul style="list-style-type: none"> • CH1 = opening/step-by-step command • CH2 = partial opening command • CH3 =courtesy light on/off command • CH4 = STOP command 	
	<p>FQ - Radio frequency selection</p> <p>The visible parameters depend by the Remote Connectivity Board (RCB) plugged in (J9 connector).</p> <ul style="list-style-type: none"> • NO - None RCB plugged in • 43 - Radio 433MHz (RCB50E or RCB100E plugged in) • 86 - Radio 868MHz (RCB50E or RCB100E plugged in) 	
	<p>VL - Enable/disable vacation mode.</p> <p>Radio commands transmitted by radio frequency devices (radio controls and digital radio keypad) are disabled.</p> <ul style="list-style-type: none"> • ON - Holiday mode enabled: locks all remote control devices (radio frequency). • OF - Holiday mode disabled: unlocks all remote control devices (radio frequency). <p>i NOTE: If enabled, the display indicates whenever a radio command is received</p>	
	<p>BT - Enable/disable Bluetooth®</p> <ul style="list-style-type: none"> • ON - Enabled • OF - Disabled 	
	<p>WF - Setting of WiFi functionality (future use)</p> <p>It is used to enable or disable the WiFi functionality .</p> <ul style="list-style-type: none"> • ON - WiFi is enabled • OF - WiFi is disabled <p>! WARNING: enabling WiFi will increase the standby power consumption of the product</p>	
	<p>WR - Request to restart the connected WiFi device (future use)</p> <p>It requires double confirm.</p>	
	<p>MA - Deletion of mobile App control permissions (future use)</p>	



Diagnostic Functions

The menu allows to manage all other parameters used for additional services (diagnostic counters, FW updating, energy saving, etc.).

Parameter	Description
	<p>AI - Automation model ID Info It is read only parameter used by Ditec Service, it gives just info about the automation model identification number.</p>
	<p>CU - Visualization of the firmware version on the control panel</p> <p> → Release 1.1 (example)</p>
	<p>UP - Firmware update Activates the card bootloader in order to update the firmware. Contact after-sales service for more information</p> <p> → → </p>
	<p>AL - Alarm counter Used to view, in sequence, the counters of alarms that have been triggered at least once (alarm code + number of times triggered). With and buttons, you can scroll through all the counters and see all the alarms recorded..</p>
	<p>AH - Alarm log Used to view, in sequence, alarms that have been triggered (maximum 20). With and buttons, you can scroll through the entire alarm log. The display shows the alarm number and code, alternated. The highest number corresponds to the most recent alarm and the lowest number (0) corresponds to the oldest alarm.</p>
	<p>AR - Alarm reset Resets all the alarms in the memory (counters and log).</p> <p> → ⌚ 2"</p> <p>i NOTE: when the installation has been completed, you are advised to delete the alarms in order to facilitate future checks.</p>
	<p>CV - Display of total manoeuvres counter</p> <p> → 182 manoeuvres (example)</p>
	<p>CP - Display of partial manoeuvres counter</p> <p> → 716 manoeuvres (example)</p>
	<p>ZP - Reset of partial manoeuvres counter</p> <p> → ⌚ 2"</p> <p>For correct functioning, you are advised to reset the partial manoeuvres counter:</p> <ul style="list-style-type: none"> • after maintenance work; • after setting the maintenance alarm interval.





CA - Setting the maintenance alarm (factory setting - alarm deactivated: 0.0 00. 00)
 You can set the required number of manoeuvres (regarding the partial manoeuvres counter) for signaling the maintenance alarm.

WARNING: when the set number of operations is reached, the alarm message appears on the display .

OA - Selecting maintenance alarm display mode

- 00 - Visualization on display (alarm message)
- 01 - Visualization on flashing light (with the automation idle, 4 flashes are made and then repeated every hour) and on display (alarm message)

CH - Display of power supply hour counter

→ → → → → 215 manoeuvres (example)

BH - Visualization of counter for power supply hours via battery

→ → → → → 215 manoeuvres (example)

SV - Saving user configuration on control panel storage module

→ → → → → → → (esempio) ⌚ 2"

WARNING: if the display visualizes flashing, the memory module may not be installed.

RC - Configuration loading

→ → → → → → → (esempio) ⌚ 2"

It's possible to load the user configurations previously stored and on the memory module of the control panel.

RL - Loading of last configuration set

→ → ⌚ 2"

The control panel automatically saves the last configuration set, and keeps it memorized in the storage module. In the event of a fault or the replacement of the control panel, the last configuration of the automation can be restored by inserting the storage module and loading the last configuration set.

EU - Erasing of user configurations and last configuration set in the storage module

→ → → → ⌚ 2" ⌚ 2"

IM - Motor current visualization



BL - Visualization of Battery voltage level

The parameter shows the battery voltage level:

- Lo - Automation stopped. Battery voltage level is low (≤ 22 V)
- 22 - Battery voltage level ≥ 22 V and < 23 V
- 23 - Battery voltage level ≥ 23 V and < 24 V
- 24 - Battery voltage level ≥ 24 V and < 25 V
- 25 - Battery voltage level ≥ 25 V and < 26 V
- 26 - Battery voltage level ≥ 26 V and < 27 V
- 27 - Battery voltage level ≥ 27 V and < 28 V
- 28 - Battery voltage level ≥ 28 V



NOTE: the parameter is visible in the menu if the main power supply is missing and the battery kit is connected. In battery mode, when there is no power supply, the automation speed is reduced to a maximum of 15 cm/s

EL - Efficiency level of the automation

- This value can be used to evaluate the mechanical quality of the gate and to understand a suitable automation choice. In case of values lower than 90%, mechanical maintenance is recommended to restore efficiency or adoption of an automation with higher performance (e.g. motor with higher power).
- During normal use, this parameter monitors the efficiency of the automation, updating its degradation status in real time:
- 90-99% High efficiency level, automation in excellent condition.
- 50%-89% Medium efficiency level, performance starts to degrade.
- 10%-49% Low efficiency level, performance is degraded, and maintenance required.



EN - Enable force detection test according EN 13241-1



When enabled, the detection of consecutive obstacle is disabled to permit the execution of the force detection test according EN 13241-1.



WARNING: the activation of test mode has a timeout, after 60 minutes the test mode will be automatically disabled for safety reason.

This operation must be carried out by qualified personnel.

UB - Door unbalanced level

It shows the level of the displacement.

- from -99 to 99 with intervals of 1 unit.
- **Negative values**

Right dot on the display is switched on: indicate an unbalanced during the closing maneuver (i.e. more power is requested during the closing).

- **Positive values**

No dots switched on: indicate an unbalanced during the opening maneuver (i.e. more power is requested during the opening).

- **Acceptable door displacement**

from 45 to 45

Example:

• from 50 to 26 → Door slightly unbalanced in closing

• from 75 to 57 → Door unbalanced in closing

• from 99 to 76 → Door very unbalanced in closing

• from 26 to 50 → Door slightly unbalanced in opening

• from 57 to 75 → Door unbalanced in opening

• from 76 to 99 → Door very unbalanced in opening



WARNING: in case of unbalanced door, verify if there are some obstruction or damage along the rail, otherwise the spring requires a new calibration.

This action must be performed by qualified personnel.

RD - Resetting of factory settings





























18. Alarms and faults



NOTE: the visualization of alarms and faults is possible with any visualization selection. The signaling of alarm messages takes priority over all other displays.

Type of Alarm	Display	Description	Operation
Mechanical alarm		M0 - Automation is not properly selected	Replace the control panel
		M3 - Automation blocked	Check the mechanical parts
		M4 - Motor short circuit	Check connection of motor
		M8 - Stroke too long	Check the rack / chain belt
		M9 - Stroke too short	Manually check that the gate moves freely
		MB - Absence of motor during a manoeuvre	Check connection of motor
		MI - Detection of third consecutive obstacle	Check for the presence of permanent obstacles along the stroke of the automation. Switch off and switch on again the system to reset the alarm. If the alarm persists call assistance service
		OD- Obstacle during opening	Check for the presence of obstacles along the automation stroke
		OE - Obstacle during closing	Check for the presence of obstacles along the automation stroke
		OF - Automation blocked on opening	Check the mechanical parts and make sure there are no obstacles along the automation stroke
		OG - Automation blocked on closing	Check the mechanical parts and make sure there are no obstacles along the automation stroke
Service alarm		HD - Power supply voltage is too high. The system stops the motor to hold the door and avoid a falling during the closing	Check the spring and the mechanical, the door could be not more balanced
Internal control		V0 - Request for maintenance intervention	Proceed with the scheduled maintenance intervention

Internal control			
Panel alarm		I7 - Internal parameter error - value outside limits	Reset. If the problem persists, replace the control panel
		I8 - Program sequence error	Reset. If the problem persists, replace the control panel
		IA - Internal parameter error (EEPROM/FLASH)	Reset. If the problem persists, replace the control panel
		IB - Internal parameter error (RAM)	Reset. If the problem persists, replace the control panel
		IC Operation time-out error (>5 min or >7 min in learning mode)	Manually check that the gate moves freely. If the problem persists, replace the control panel.
		IE - Power supply circuit fault	Reset. If the problem persists, replace the control panel
		IM - MOSFET alarm Motor in short circuit or always ON	Reset. If the problem persists, replace the control panel
		IN - Interrupted motor power circuit (motor MOSFET open or always OFF)	Reset. If the problem persists, replace the control panel
		IR - Motor relay error	Reset. If the problem persists, replace the control panel
		IS - Error on motor current read circuit test	Reset. If the problem persists, replace the control panel
		TH - Intervention of high temperature safety device	Do not carry out any operations. If the problem persists, contact Technical Service
		VH - Automation blocked due to high temperature	Do not carry out any operations. If the problem persists, contact Technical Service
		XX - Firmware reset	
		WD - Firmware reset not commanded	
		EN - Error on the encoder during a manoeuvre	Check connection of motor

Radio operations alarm		R3 - Storage module not detected	Insert a storage module
		R4 - Storage module not compatible with the control panel	Insert a compatible storage module
		R5 - No serial communication with the storage module	Replace the storage module
Power supply alarm		P0 - No mains voltage	Check the control panel is powered correctly. Check the line fuse. Check the mains power supply
		P1 - Microswitch voltage too low	Check the control panel is powered correctly
Battery alarm		B0 - Battery almost flat	Check battery voltage. Replace battery
Accessory alarm		A7 - Incorrect connection of terminal 9 to terminal 1	Check that terminal 1 and 9 are correctly connected
		A9 - Overload on output +LP-	Check the device connected to output +LP- is working properly
		AB - Courtesy Light short circuit	Check the connection. If the error persists replace the courtesy light
		AP - Photocell short circuit or wires inverted	Check the connection
		PF - Photocell test failed	Check the connection. If the error persists replace the photocell
		AW - Wall station short circuit or wires inverted	Check the connection

19. Maintenance

Six-monthly maintenance activities

- Check the emergency release is working properly.
- Check the safety devices (if installed) are working properly.
- Check the obstacle detection function is working properly.
- Check the stability of the automation

Disconnect the power supply, 230 V-:

- Lubrication of mechanical parts must be performed with door down.
- Make sure that cable and spring breakage device is in perfect working order.
- Check lift-cable wear.
- Make sure that the cables run smoothly in the drums.
- Periodically grease the hinges, ball-bearings, wheel pins, and torsional springs.
- Check for any obstacles that may hinder the wheels from properly running in the guides.
- To check the correct balancing of the sectional automation.
- Make sure that the overhead sliding structure is firmly fastened to the ceiling and perfectly free from any defects, bending or buckling.
- Make sure that there are no loose bolts or screws.
- Absolutely avoid making any changes to the hoisting and/or sliding system.

Connect the power supply (230 V-) and check that:

- Limit switches are working properly.
- All control and safety functions are in good working order.

20. Installation of accessories

20.1 Installation of the adapter AIRSB for up-and-over doors

In applications for up-and-over doors, you must use the AIRSB adapter.

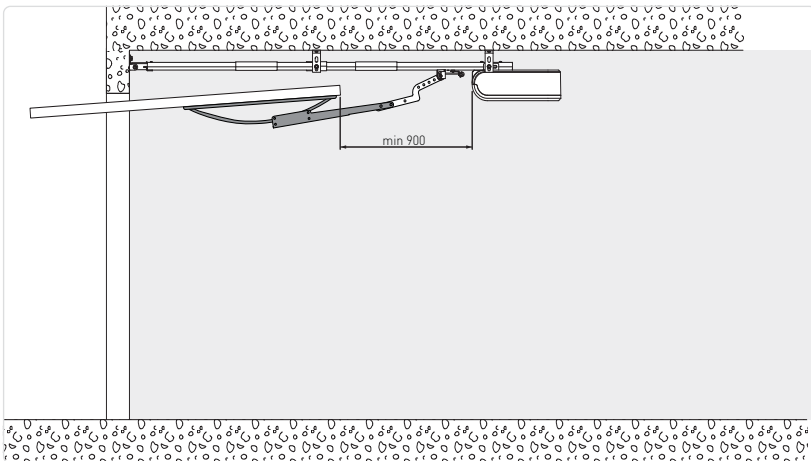
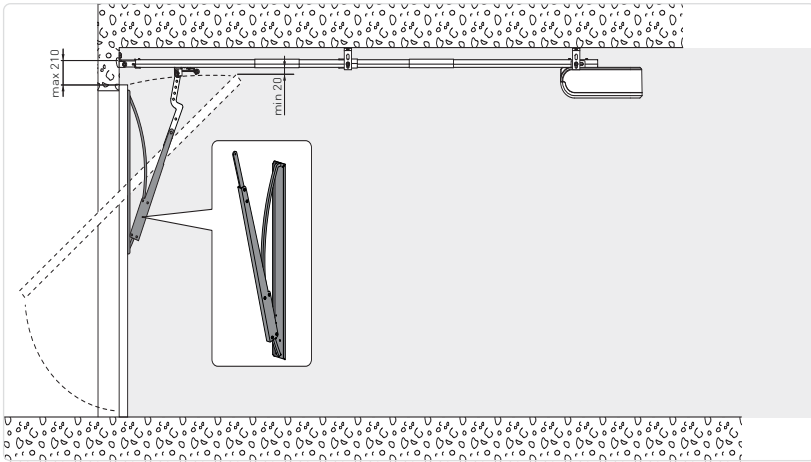

For complete instructions see manual:



AIRSB

IP2433EN

20.2 Installation of the high-brightness LED light 3500 lms (ref. LEDLGT4K35)

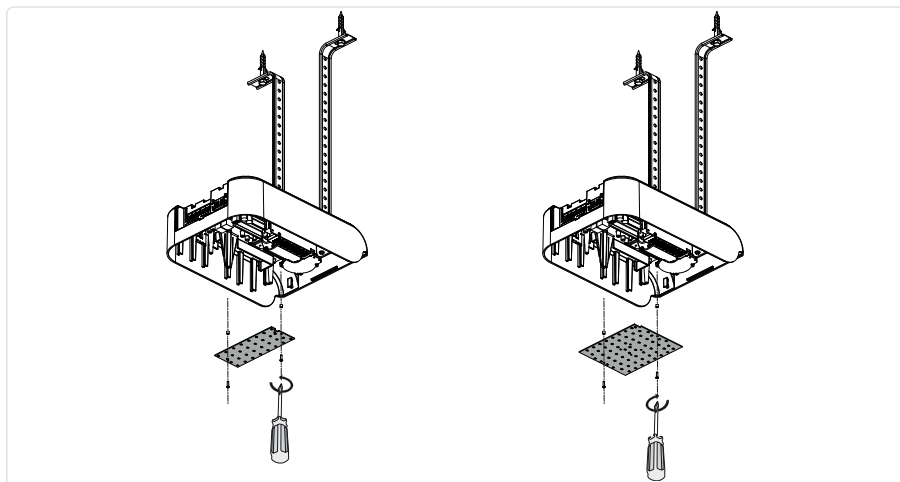

20.3 Installation of AIR motor on rail TOP803T3 - TOP803T4 (ref. TSRFK)

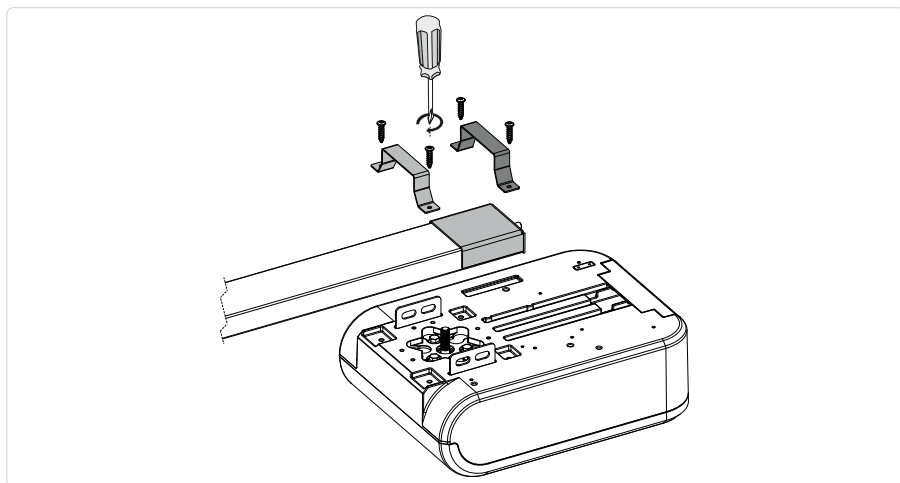

For complete instructions see manual:



LEDLGT4K35



TSRFK

The Bluetooth® word mark and logos are registered trademarks owned by Bluetooth SIG, Inc. and any use of such marks by ASSA ABLOY Entrance Systems AB is under license.

All the rights concerning this material are the exclusive property of ASSA ABLOY Entrance Systems AB. Although the contents of this publication have been drawn up with the greatest care, ASSA ABLOY Entrance Systems AB cannot be held responsible in any way for any damage caused by mistakes or omissions in this publication. We reserve the right to make changes without prior notice. Copying, scanning or changing in any way is expressly forbidden unless authorised in writing by ASSA ABLOY Entrance Systems AB.

 The crossed-out wheelie bin symbol indicates that the product should be disposed of separately from normal household waste. The product should be recycled in accordance with local environmental regulations for waste disposal. By separating a product marked with this symbol from household waste, you will help reduce the volume of waste sent to incinerators or land-fill and minimise any potential negative impact on human health and the environment.



ASSA ABLOY Entrance Systems AB
Lodjursgatan 10
SE-261 44, Landskrona
Sweden
© ASSA ABLOY