

PASP

PASSIVE INFRARED SENSOR FOR AUTOMATIC DOORS*

User's Guide for product version 0202 and higher
See product label for serial number.

DESCRIPTION

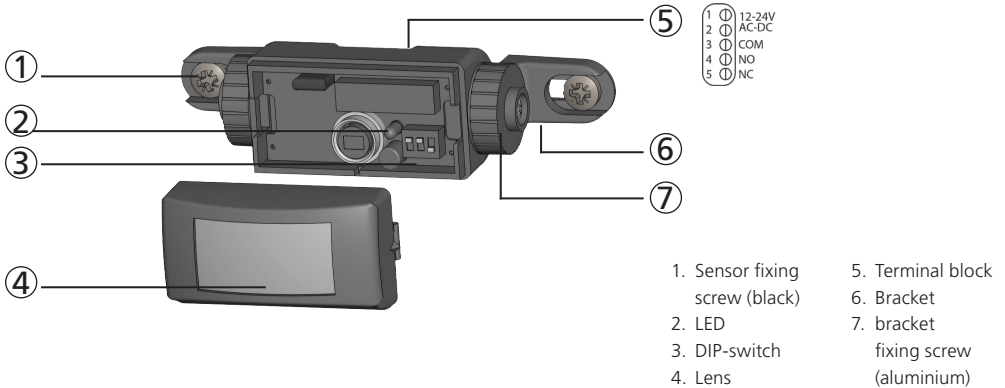

TECHNICAL SPECIFICATIONS

Technology :	passive infrared and microprocessor
Optical characteristics:	P.I.R. with 4 elements, 15 lenses with full independent masking possibilities
Maximum Detection area (mounting height: 2.2m):	2.5 m (W) x 1.5 m (D)
Minimum Detection area (mounting height: 2.2 m)	0.5 m (W) x 0.5 m (D)
Detection mode:	motion
Detection speed:	0.1 to 1.5 m/s
Light indicator:	1 red LED:flashes for a few seconds after power-on LED lights up: sensor detects motion
Warm up time:	10 s
Hold time:	0.5 s ou 2 s
Response time:	< 200 ms
Power supply:	12 VDC - 10% à 24VDC +30% /12 to 24 V AC ±10%
Frequency:	50/60 Hz
Power consumption:	< 1 W
Connection:	terminal block
Recommended cable section (terminal block):	< 0.5 mm ²
Standard output:	relay (free potential contact)
Max. contact voltage:	60 V DC / 42 V AC
Max. contact current:	1A (resistive)
Max. switching power:	30W (DC) / 42 VA (AC)
Mounting height:	3 m max
Temperature range:	from -30 °C to +55 °C
Dimensions:	
Sensor:	101 mm (W) x 41 mm (H) x 27 mm (D)
Entrematic PASP:	121 mm (W) x 51 mm (H) x 40 mm (D)
Color (Sensor-PASP):	anthracite grey
Length of cable:	2.5 m
Conformity:	EN 61000-6-2; EN 61000-6-3; EN 50581

Specifications are subject to changes without prior notice.
Measured in specific conditions.

* Other use of the device outside of the permitted purpose can not be guaranteed by the manufacturer.

1 OPENING AND CLOSING THE SENSOR

SENSOR

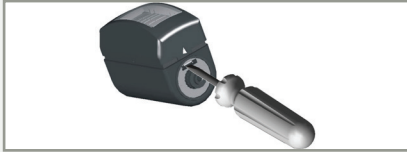

To open the sensor, insert a screwdriver in the hole under the bracket cam.



Consider the position of the guide pin when closing the sensor.

FRONT COVER



To remove the cover, insert a screwdriver as shown (left) or pinch off both sides of the front cover (right).



Insert the bottom of the front cover to the bottom clip of the base and push to close the sensor.

2 MOUNTING THE SENSOR

SENSOR

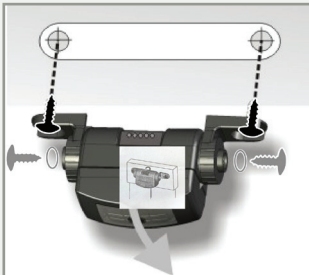

1. Stick the template to the internal profile.
2. Drill the 2 holes.
3. Fix the brackets to both sides of the sensor with the 2 aluminum screws.
4. Fix the sensor, with the connector facing you, to the profile with the 2 black screws.
5. Make the cut-out in the door profile.
6. Connect the sensor using the cable (See p. 1 for wiring).
7. Adjust the tilt angle using the brackets.

1. Stick the template to the wall.
2. Drill the 2 holes to fix the sensor and the hole for the cable.
3. Open the sensor and cut out a wire opening footprint.
4. Fix the sensor to the base with **the 2 aluminum screws** supplied with the PASP.
5. Connect the sensor using the cable.
6. Fix the sensor with the **2 black screws** and close the sensor.

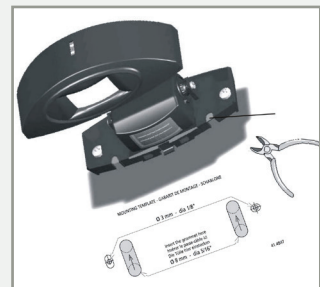

PASP



1. Stick the template to the ceiling and cut out the hole.
2. Clip the sensor on the FCA and fix it with **the 2 washers and the 2 aluminum screws**.
3. Connect the sensor using the cable.
4. Insert the complete assembly into the ceiling and fix it using **the 2 long, black screws**.

3 DIP SWITCH SETTINGS

	DIP SWITCH #1	DIP SWITCH #2	DIP SWITCH #3
ON	Sensitivity high	Passive output (NC)	Hold time: 2 s
OFF	Sensitivity low (mounting height < 2.2m)	Active output (NO)	Hold time: 0.5 s

4 SENSING FIELD SETTINGS

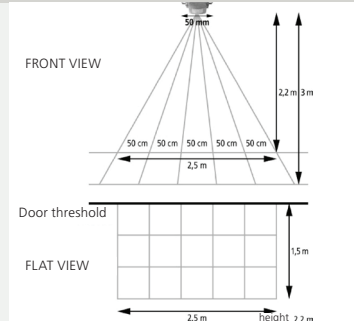
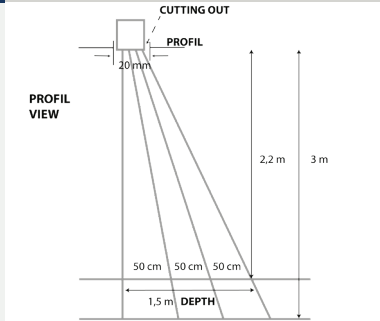

The drawings show the maximum sensing field dimensions. If you install the PASP without accessories, you can move the sensing field position by tilting the sensor to select the required vertical tilt angle. Otherwise, this adjustment is not possible.

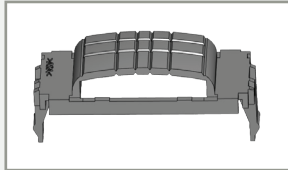

To adjust the sensing field, use the masking lens. To tailor the sensing field, cut the segments.

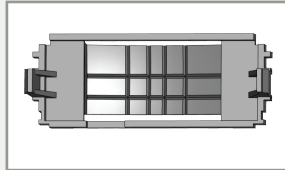

Use the guide pins to insert the masking lens on the front cover.

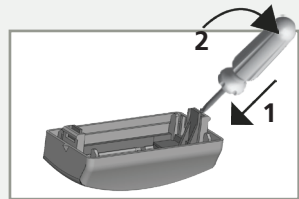

Position the screwdriver as shown to remove the masking lens.

EXAMPLES:

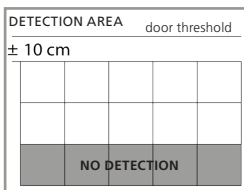
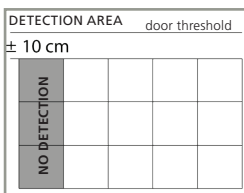

INSTALLATION TIPS

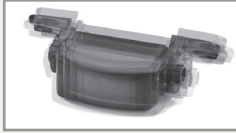

The sensor must be firmly fastened in order to avoid vibrations!



When mounting the PASP, make sure you apply the brackets before tightening the screws.

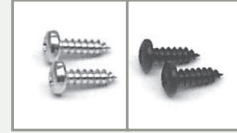

Always use the aluminium screws to fasten the accessories and the black screws to fix the sensor. Using the wrong screws could damage the sensor!

TROUBLESHOOTING



The door remains closed. The LED is OFF.

The sensor power is off.

1 Check the wiring and the power supply. check the supplied voltage.



The door will not open and the LED lights up.

The wiring of the relay output is not connected correctly.

1 Check the relay wiring.

The door opens when no detection occurs and closes during detection.

The mode of the relay output is not correct.

1 Change the position of dip-switch 2.

The sensing field does not correspond to your requirements.

The cut of the masking lens is wrong.

1 Cut out a new lens to meet the required sensing field size.

The detection is very bad.

The sensor might be installed upside down.

1 Check if the sensor is installed with its connector facing you.

