

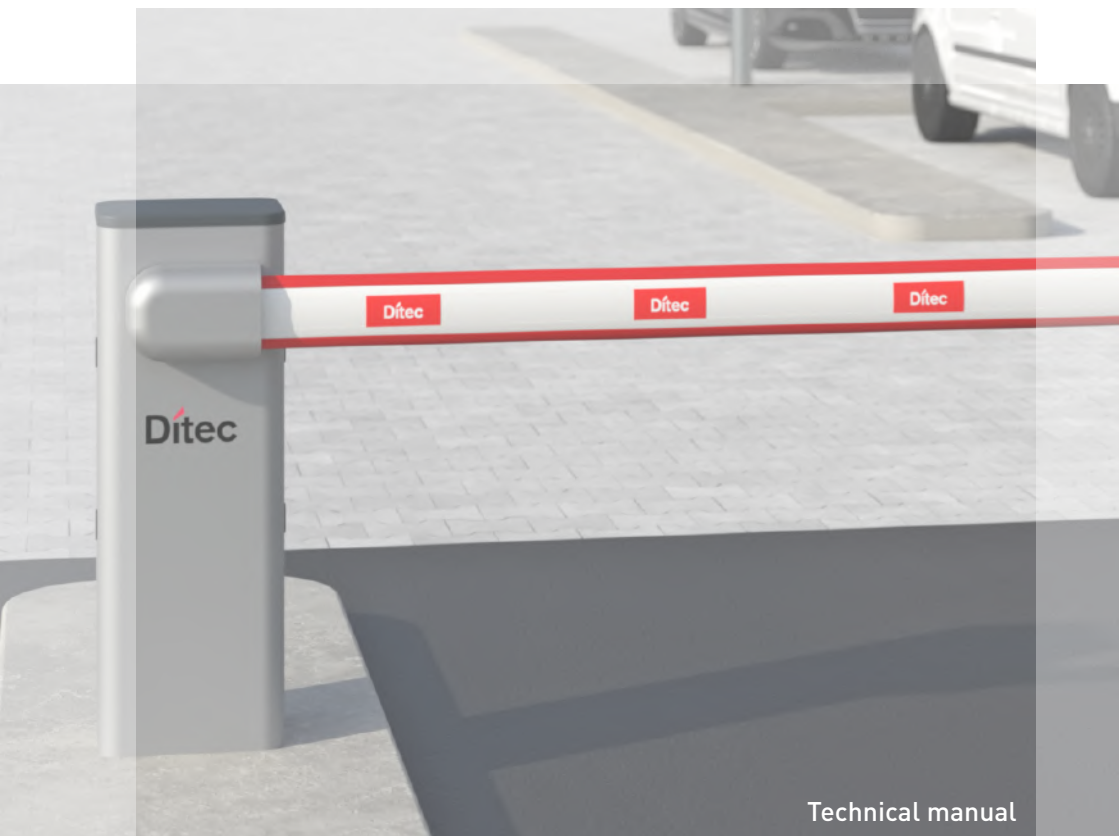

Latest version of this manual

Dítec

IP2458EN • 2026/01/26



Technical manual

Dítec SPID40B - SPID60B

Electromechanical barrier

(translation of the original instructions)

GENERAL SAFETY PRECAUTIONS

 **ATTENZIONE!** Important safety instructions • Follow the instructions carefully • Failure to observe the information given in this manual may lead to serious injury or serious damage to the equipment • Keep these instructions for future reference

 **ATTENZIONE!** Before carrying out any cleaning or maintenance operations, disconnect the power supply • This manual and the manuals of any accessories can be downloaded from the website: www.ditecautomations.com

SAFETY PRECAUTIONS FOR TECHNICAL PERSONNEL

 This installation manual is intended for qualified personnel only • Installation, electrical connections and adjustments must be carried out by qualified personnel, in accordance with the criteria of good technique and in compliance with current legislation • Read the instructions carefully before installing the product. Incorrect installation could be dangerous • Before installing the product, make sure it is in perfect condition • The packaging materials (plastic, polystyrene, etc.) must not be thrown into the environment or left within reach of children, as they are a potential source of danger • Do not install the product in explosive areas and atmospheres: the presence of gas or flammable fumes represents a serious safety hazard • Make sure that the temperature range indicated in the technical specifications is compatible with the place of installation • Before installing the motorised device, make sure that the existing structure, as well as all the support and guide elements, are compliant in terms of resistance and stability. Check the stability and smooth movement of the barrier and check that there is no risk of falling or derailment. Make all the necessary structural changes to create a safety clearance and to protect or isolate all areas with the risk of crushing, cutting, trapping and that are generally dangerous • The safety devices (photocells, safety edges, emergency stops, etc.) must be installed taking into account the applicable laws and directives, the criteria of good technique, the place of installation, the operating logic of the system and the forces developed by the motorised barrier •

The safety devices must protect against crushing, cutting, impact and general danger areas of the motorised barrier. Display the legally required signs to identify the danger areas • Each installation must display the visible indication of the motorised barrier

 identification data • Before connecting the power supply, make sure the data on the identification plate correspond to that of the mains power supply. An omnipolar disconnector with a contact opening distance of at least 3 mm must be mounted on the mains power supply. Check that upstream of the electrical system there is an adequate differential switch and a suitable overcurrent disconnector according to the criteria of good technique and current laws • If required, connect the motorised barrier

 to an operational earthing system that complies with current safety standards • The electrical components must be moved using earth-connected anti-static conductive arms. The manufacturer of the motorisation device declines all responsibility

 if parts of the components not compatible with safe and correct operation have been assembled • Only use original spare parts for the repair or replacement of the products • Before putting the system into service for the end user, make sure that the automation is properly adjusted in order to meet all the functional and safety requirements, and that all the control, safety and manual release devices are working correctly • The installer must provide all the information regarding the automatic, manual and emergency operation of the automation and must provide the user with the operating and safety instructions.

GENERAL SAFETY PRECAUTIONS FOR THE USER

These precautions are essential and an integral part of the product and must be provided to the end user. Read the instructions carefully because they contain important safety information for installation, use and maintenance. These instructions must be kept and transmitted to all possible future users of the product • This product must only be used for the specific purpose for which it was designed. Any other use should be considered improper and therefore dangerous. The manufacturer cannot be held responsible for any damage caused by incorrect, improper or unreasonable use • Do not work near hinges or moving mechanical parts. Do not enter within the operating range of the motorised barrier when moving. Do not hinder the movement of the motorised barrier, as this could cause a dangerous situation • Lock and unlock the barrier only when the motor is off • The motorised barrier can be used by children over the age of 8 and by people with reduced physical, sensorial or mental abilities, or with little experience or knowledge, as long as they are properly accompanied or have been instructed on the safe use of the device and its hazards • Children must be supervised to ensure that they do not play or remain in the area of action of the motorised barrier. Keep remote controls and/or any other control devices out of the reach of children, to avoid accidental activation of the motorised door • The cleaning and maintenance operations intended for the end user must not be carried out by children, unless they are supervised. In the event of a fault or malfunction of the product, disconnect the power supply cable. Do not attempt to repair or intervene directly. All repairs or technical interventions must be carried out by qualified personnel. Failure to comply with the above can cause dangerous situations • To ensure efficient and correct operation of the automation, the manufacturer's instructions must be respected and routine maintenance must be carried out by qualified personnel. In particular, it is recommended to carry out periodic checks to verify the correct operation of the safety devices • All installation, maintenance and repair work must be documented and made available to the user • This device may contain batteries that can only be replaced by authorised service personnel • If the power cable is damaged, it must be replaced by the specialised technicians of the manufacturer, the installer or similarly qualified persons, in order to avoid a hazard • Activation of the manual release may cause uncontrolled movement of the barrier due to a mechanical failure or a condition of mechanical imbalance • The A emission sound pressure level of the appliance must be less than or equal to 70 dB(A).

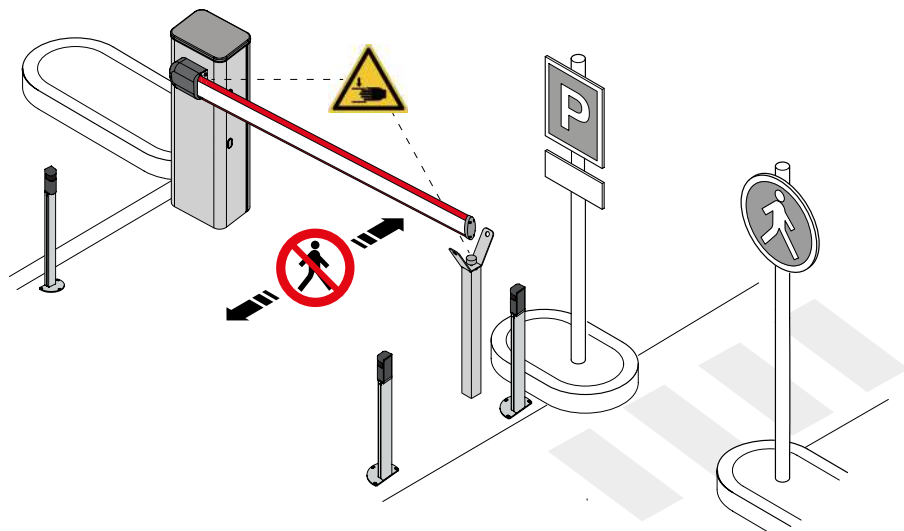



MANUAL RELEASE PROCEDURE

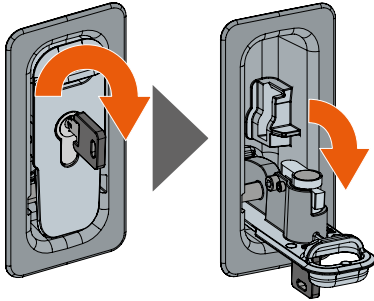

EXTERNAL MANUAL BARRIER RELEASE

Reference paragraph 12.1

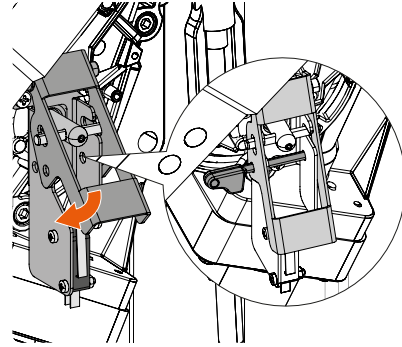

INTERNAL MANUAL BARRIER RELEASE

Reference paragraph 12.3



DO NOT RELEASE WITH THE SPRINGS TENSIONED WITHOUT THE ARM. PERFORM ARM LOCKING AND RELEASE WITH THE MOTOR SWITCHED OFF. WHEN THE BARRIER IS RELEASED, THE ARM MAY MOVE OF ITS OWN ACCORD.

Machinery Directive

Pursuant to the Machinery Directive (2006/42/EC), the installer who motorises a door or gate has the same obligations as the manufacturer of machinery and as such must:

- prepare the technical file that must contain the documents indicated in Annex V of the Machinery Directive (The technical file must be kept and placed at the disposal of competent national authorities for at least ten years from the date of manufacture of the motorised door);
- draw up the EC Declaration of Conformity in accordance with Annex II-A of the Machinery Directive and deliver it to the customer;
- affix the EC marking on the motorised door or gate, in accordance with point 1.7.3 of Annex I of the Machinery Directive;
- Ensure that the motorised door or gate complies with the safety regulations, installing the necessary safety devices.

INDEX

1. TECHNICAL SPECIFICATIONS	8
1.1 OPERATING INSTRUCTIONS	9
1.2 DIMENSIONS	9
1.3 MAIN COMPONENTS	10
2. INSTALLATION	11
2.1 STANDARD INSTALLATION	11
2.2 BASE INSTALLATION	12
2.3 CABINET OPENING	13
2.4 CABINET INSTALLATION	13
2.5 SELECTING THE OPENING DIRECTION	14
2.6 BOOM INSTALLATION	16
2.6.1 ANCHOR LEVER PRE-SETTING	16
2.6.2 Small Profile Boom	16
2.6.3 Elliptic Profile Boom	17
2.7 SPRING INSTALLATION	19
2.7.1 BALANCING	20
2.7.2 SPB - SPRING CONFIGURATION TABLES	20
2.7.3 EPB - SPRING CONFIGURATION TABLES	21
2.8 ADJUSTMENT OF MECHANICAL LIMIT STOPS	22
3. ELECTRICAL CONNECTIONS	23
4. LCU55 BOARD	25
4.1 LED SIGNALS	26
4.2 JUMPER SETTINGS	26
5. COMMANDS AND SAFETY DEVICES	27
5.1 INPUTS	27
5.2 SAFETY INPUTS	27
5.3 OUTPUTS AND ACCESSORIES	28
6. PRODUCT START-UP	29
6.1 SETTING THE OPENING DIRECTION	29
6.2 SETTING THE BOOM LENGTH	30
6.3 SETTING THE BOOM WEIGHT (installed accessories)	30
6.4 START-UP TEST	30

7.	LCU55 PARAMETERS	31
7.1	MAIN LEVEL MENU.....	31
7.2	FREQUENT USE MENU.....	31
7.3	COMPLETE MENU MAP	32
7.4	“FREQUENT USE” MENU – PARAMETER DESCRIPTION.....	34
7.5	FULL MENU – PARAMETER DESCRIPTION.....	37
8.	EXAMPLES OF INSTALLATION.....	53
8.1	PARALLEL WIRING DIAGRAM.....	53
9.	SIGNALS VISUALISED ON THE DISPLAY	55
9.1	DISPLAYING TEMPORARY SAFETY MESSAGES	55
9.2	DISPLAY OF ALARMS AND FAULTS.....	56
10.	TROUBLESHOOTING	59
11.	CABINET CLOSURE.....	61
12.	MANUAL RELEASE INSTRUCTIONS.....	62
12.1	EXTERNAL MANUAL BARRIER RELEASE	62
12.2	RIPRISTINO DEL FUNZIONAMENTO AUTOMATICO.....	62
12.3	INTERNAL MANUAL RELEASE OF THE BARRIER.....	63
12.4	RESET OF AUTOMATIC OPERATION	63
13.	ROUTINE MAINTENANCE PLAN.....	64



This symbol indicates notes and/or information useful or the correct operation of the product.







This symbol indicates a note regarding safety, to which special attention must be paid.



This symbol indicates the default value of the parameter.

1. TECHNICAL SPECIFICATIONS

	Ditec SPID40B	Ditec SPID60B
Power supply	100 - 240 V~, 50-60 Hz	
Power	100 W	150 W
Standby	< 0,6 W (accessories disconnected)	< 0.8 W (accessories disconnected)
Service class	VERY INTENSE (tested up to 2,500,000 cycles)	
Max. arm length	up to 4000 mm (net passage)	up to 6000 mm (net passage)
Intermittent operation*	CONTINUOUS OPERATION	
Cycles / hour*	320 Cycles/h	240 Cycles/h
Temperature of use (T)	 -20°C  +55°C	 -35°C  +55°C with NIO enabled
Opening time	2,5 s – 6 s/90° (2 s - 5,5 s/80° + 0,5 s slowdown)	3,5 s – 6 s/90° (3 s - 5,5 s/80° + 0,5 s slowdown)
Closing time	2,5 s – 6 s/90° (2 s - 5,5 s/80° + 0,5 s slowdown)	3,5 s – 6 s/90° (3 s - 5,5 s/80° + 0,5 s slowdown)
Control panel	LCU55	
Protection rating	IP54	
Motor output	24V ≡ 10A max	
Accessories power supply	24V ≡ 0,3A max	
Radio Frequency	433.92 MHz (RO → FQ → 43) 868.35 MHz (RO → FQ → 86)	 RCB100E receiver module included.
Radio codes storable	cod. BIXMR2 100= (RO → FQ → MU / 10) 200= (RO → FQ → MU / 20)	
Noise level L _{pA}	≤70 dB (A)	

A cycle is defined as an opening movement → pause → closing movement → pause. (T = 25°C)

*SPID40B: Indicative cycles considering a 4.2 m boom with default opening/closing speed.

*SPID60B: Indicative cycles considering a 6.2 m boom with default opening/closing speed.

1.1 OPERATING INSTRUCTIONS

Applications: VERY INTENSE (for apartment block, industrial and commercial entrances and car parks with vehicle access or access for very intense pedestrian use). Service class, running times, and the number of consecutive cycles are to be taken as indicative. They have been statistically determined under average operating conditions and therefore not necessarily applicable to specific conditions of use.



Each automatic system has variable elements such as: friction, balancing and environmental factors, all of which may substantially alter the service life and performance of the system or its components, including the spring. The installer should adopt suitable safety conditions for each particular installation.



Tests have shown that the average spring lifespan is around 500,000 cycles, so you are advised to check its state of wear when this limit is reached. If there are clear signs of wear, or it is difficult to balance the arm correctly, replace the spring.

1.2 DIMENSIONS

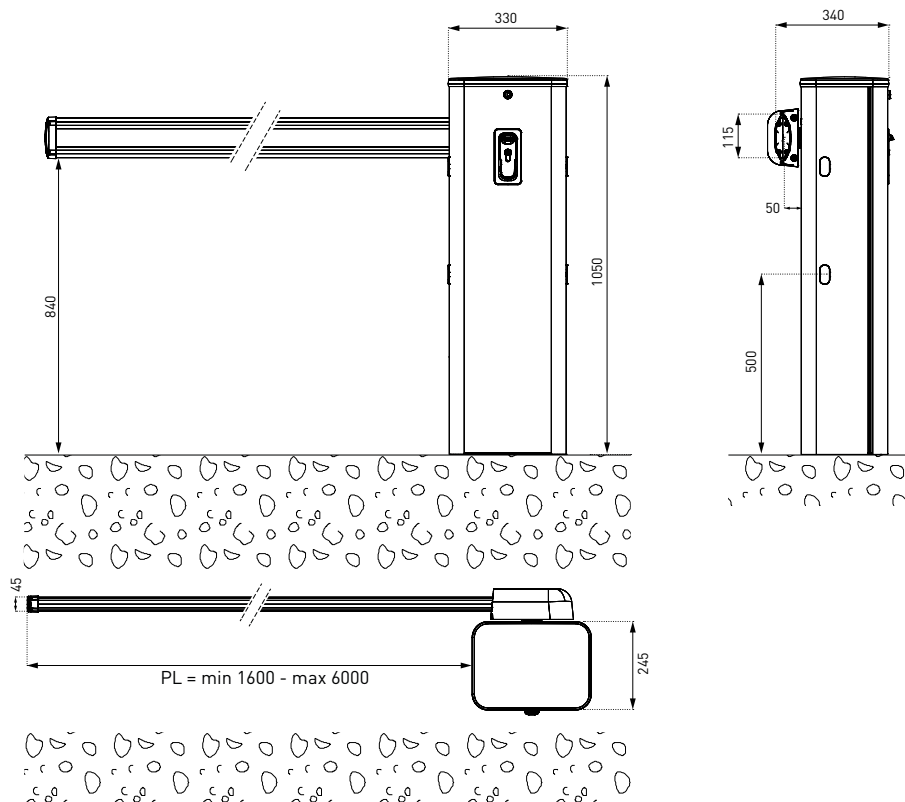

IP2458EN

1.3 MAIN COMPONENTS

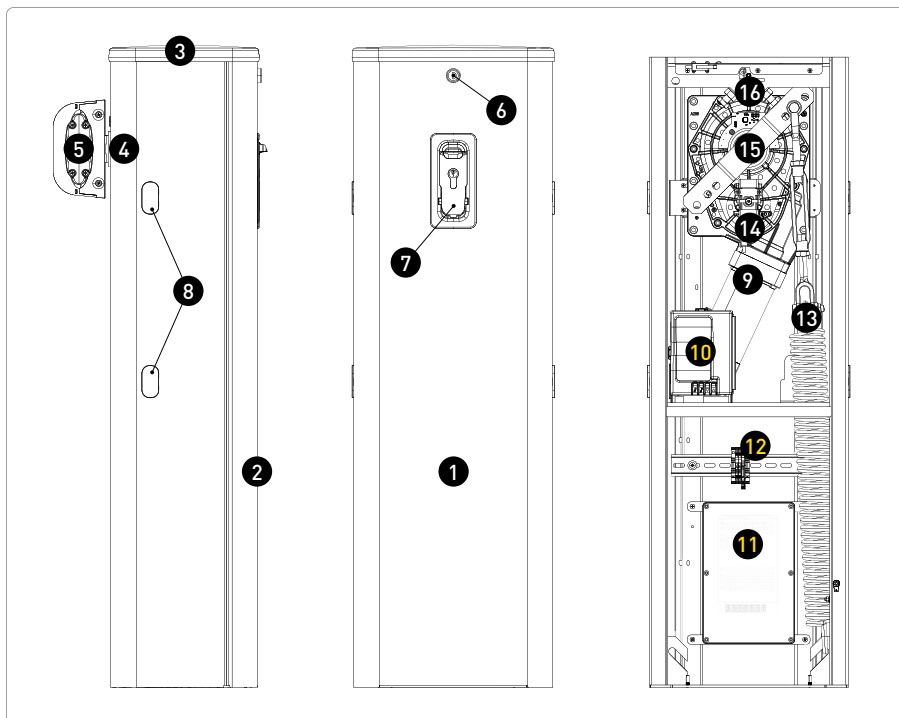

Ref.	Code	Description
1		Cabinet (machine body)
2		Front door
3		Top cover
4		Transmission shaft
5		Elliptical arm
6		Front door locking
7		Manual barrier release
8		Photocell seats
9		24 V = Motor
10	LCU55	Control panel
11		Transformer - power supply unit
12		230 V DIN terminal block
13	BSP1 BSP2 BSP3 BSP4	Gray spring (Φ6 mm) Green spring (Φ7 mm) Yellow spring (Φ8.5 mm) Red spring (Φ10.5 mm)
14		Internal manual release of the barrier
15		Anchor lever
16		Mechanical limit switches

2. INSTALLATION



Carry out the following installation operations with the power supply disconnected.

2.1 STANDARD INSTALLATION

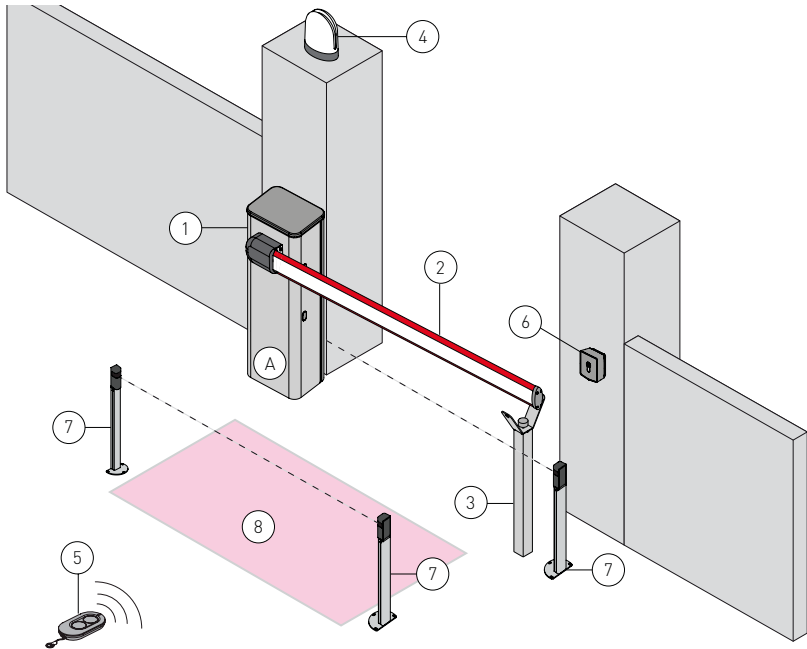

Code	Description	Code	Description		
1	SPID40B Barrier cabinet + built-in control panel SPID60B	AXK4	Digital combination wireless keypad		
2	SPB	Special profile boom	AXK5M	Wall-mounted key-operated selector switch with European cylinder	
	EPB	Elliptic profile boom	AXK5N	Semi-recessed key-operated selector switch with European cylinder	
	EPBJT	Elliptical boom joint	AXK5NM	Wall-mounted key-operated selector switch without cylinder	
	BART	Articulated joint for elliptical boom	AXK5NI	Semi-recessed key-operated selector switch without cylinder	
	LEDSRG	Boom lighting kit	AXR7	RFID reader unit	
	DRS10	Boom reflectors	7	LIN2-LIN2B	Photocells
	BALSK20	Aluminum fence 2000 mm		AXP2-LAB4	Photocell support
3	BFIS	Fixed support	8	LAB9	Magnetic loop detector for passage control
	BFISE	Fixed support with electromagnetic lock			
4	FL24 - FLM	Flashing light	Connect the power supply to a certified omnipolar switch with a contact opening distance of at least 3 mm (not supplied). The connection to the mains must be made in an independent conduit, separate from the wiring of control and safety devices.		
5	ZEN	Transmitter - remote control			
A					

IP2458EN



The given operating and performance features can only be guaranteed with the use of DITEC devices.

2.2 BASE INSTALLATION

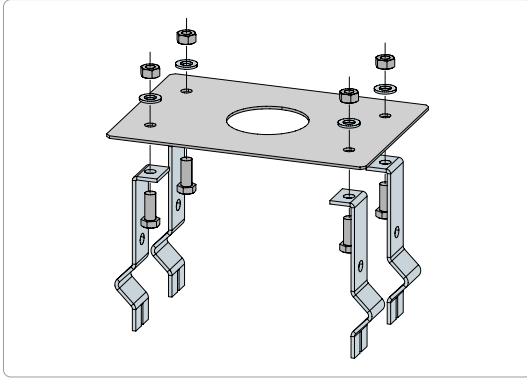

Prepare a concrete base:

1. Dig a trench for the counter frame and prepare the necessary corrugated pipes for the connections coming from the connector chamber;
2. Insert the iron grid to reinforce the concrete that will fill the counter frame;
3. Fill the counter frame with cement and drown the anchor ties of the base plate;
4. Pass the cable ducts through the central hole of the plate, which must be level and clean;
5. Wait for the concrete to consolidate (at least 24 hours) Subsequently, remove the counter frame and use excavation material to fill around the base;
6. Remove the nuts from the fixing screws of the ties and insert the electrical cables into the pipes until they come out about 1500 mm.

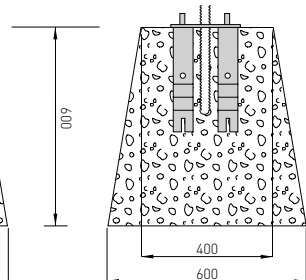
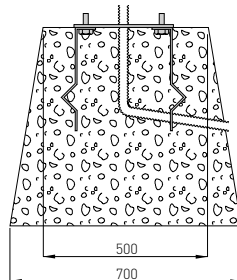
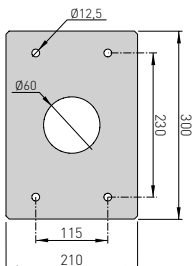
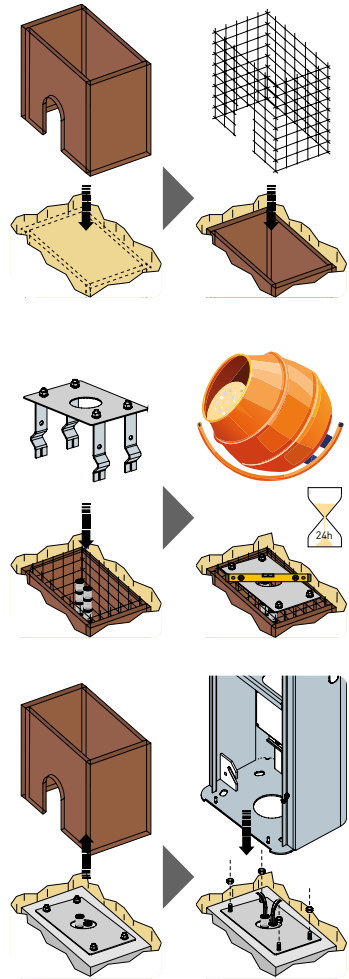

2.3 CABINET OPENING

1. Insert and turn the key **A** clockwise until it stops.
2. Remove the upper cover **B**.

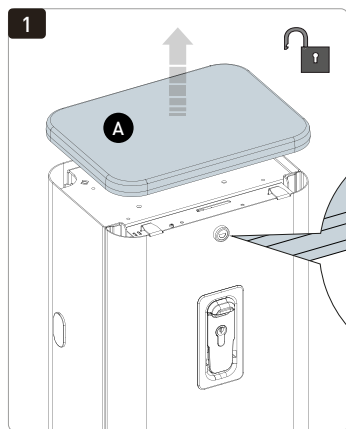

3. Remove the door, first removing it from the upper slots **C** with an upward push, tilting it and removing it from the lower guides **D**.

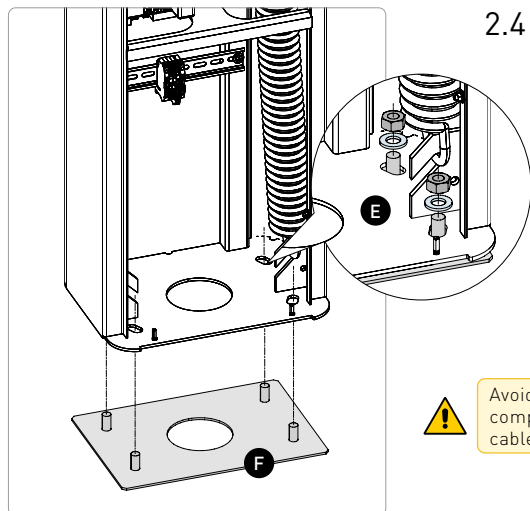
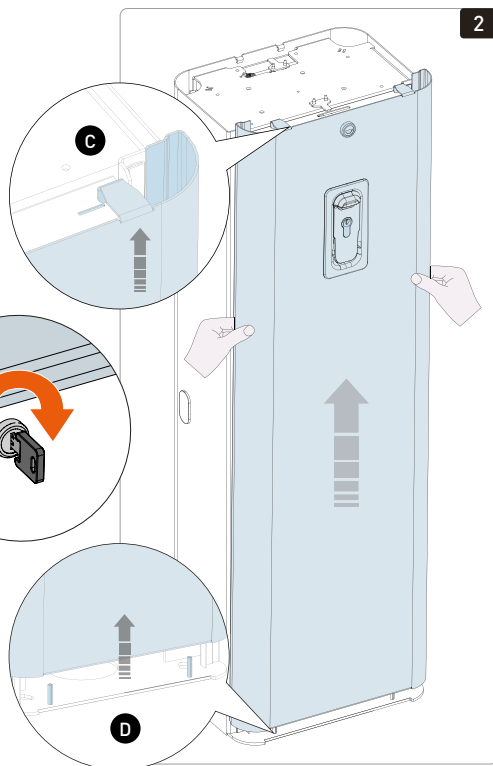

2.4 CABINET INSTALLATION

Place the barrier body **E** on the base plate, in correspondence of the 4 fixings, being careful not to damage the pipes of the electrical cables.

Fix the barrier body using the nuts with the relative washer on each fixing of the base plate **F**.





Avoid ergonomic risks due to the weight of the components and do not damage the electrical cable pipes.

2.5 SELECTING THE OPENING DIRECTION

The barrier is normally supplied in the right version. Conventionally, a right barrier is defined as one which, when viewed from the front from the side of the opening door, opens the passage by raising the arm to the right. In any case, it is possible, with a few simple operations, to modify a right barrier to obtain a left barrier.

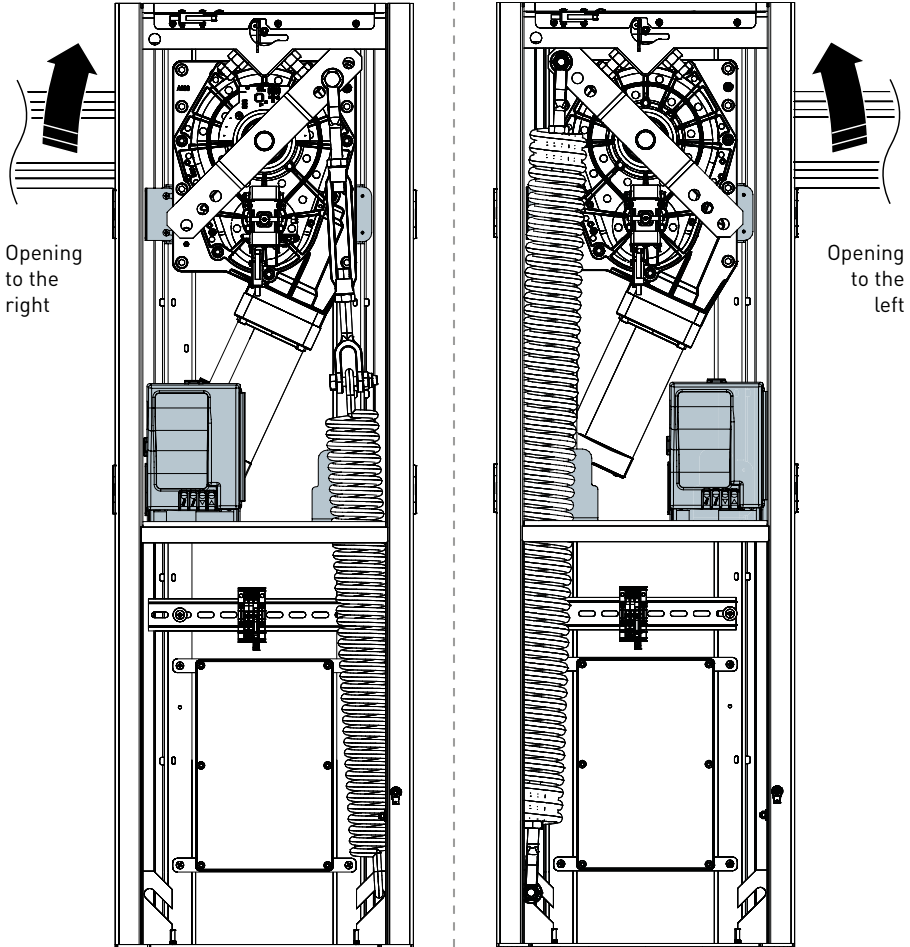
Choose the direction of opening of the barrier by carrying out the following operations:



- Manually release  the barrier (see paragraphs 12) and position the arm in the vertical opening position;
- Completely release the spring, manually unscrewing the tie rod and removing it from the anchoring lever (ref. paragraph 2.7);
- Position the springin (ref. paragraph 2.7);



The reversal of the opening direction requires the modification of some parameters, as indicated in paragraph 7.

- Based on the chosen opening direction, prepare the position of the electrical panel **B** and any accessories inside the cabinet **A** (ex. photocell mounting brackets).

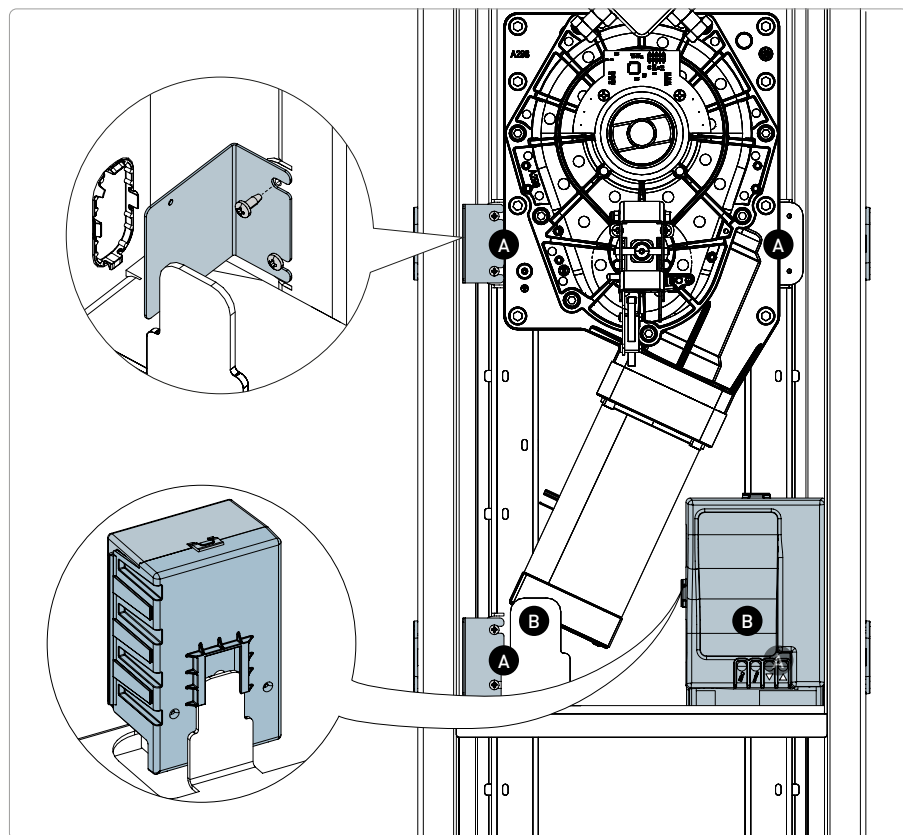

Before installing the boom, check the fixing of the barrier body and the integrity of the various elements that compose it. Any accessories (protective profiles, lights, sensitive edge, rack, etc.) must be installed before fixing it.

LEDSR-SRG

BALSK20

EPBJT



BART

BMOS

BFISE

2.6 BOOM INSTALLATION

2.6.1 ANCHOR LEVER PRE-SETTING

- Carry out the manual release  operation of the barrier (ref. paragraph 12);
- Rotate the shaft to bring the anchoring lever up against the mechanical limit switch, according to the opening direction (ref. paragraph 2.5).
- Once the boom has been installed, restore automatic operation  (ref. paragraph 12.4).



To make installation easier, use one or more end support stands.

2.6.2 Small Profile Boom

According to the desired net passage (PL):

1. Cut the boom, if necessary, to the specified length (PL+250mm).
2. Press-fit the lower bumper.
3. Cut the bumper, if necessary, to the specified length (PL+70mm).
4. Secure the end cap using the corresponding 2.9x9.5 TYPE-F screws.

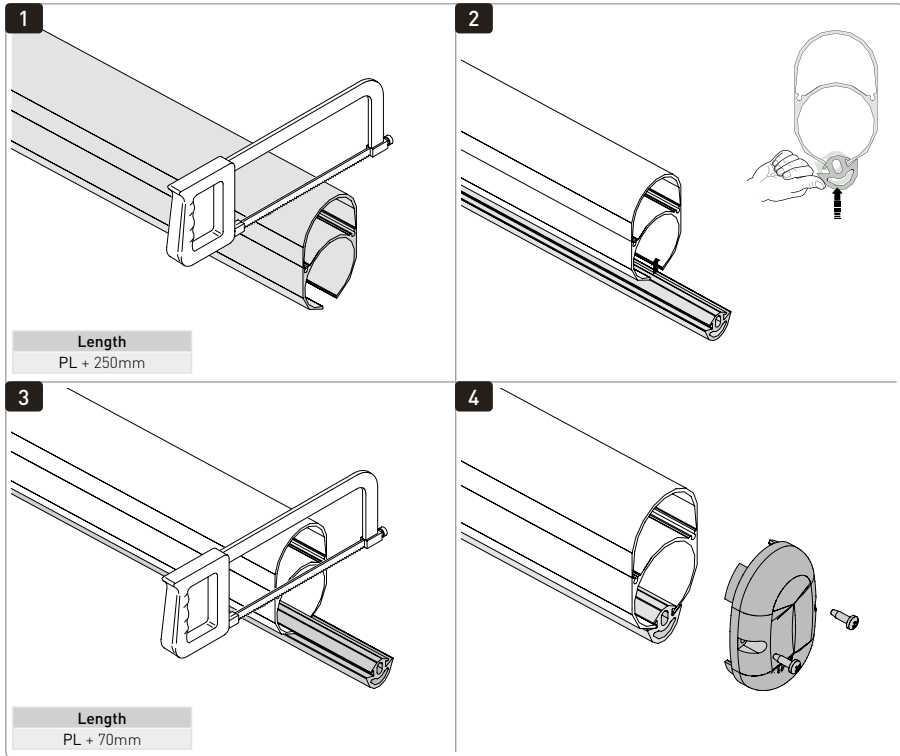

5. Position the rear clamp, aligning it with the threaded holes on the drive shaft and, using the M12_R120 washers, fasten it with the four M12x25 screws.
6. Bring the boom into position and secure it to the assembly using the front clamp. Use the four M8x25 screws to fasten the clamps.

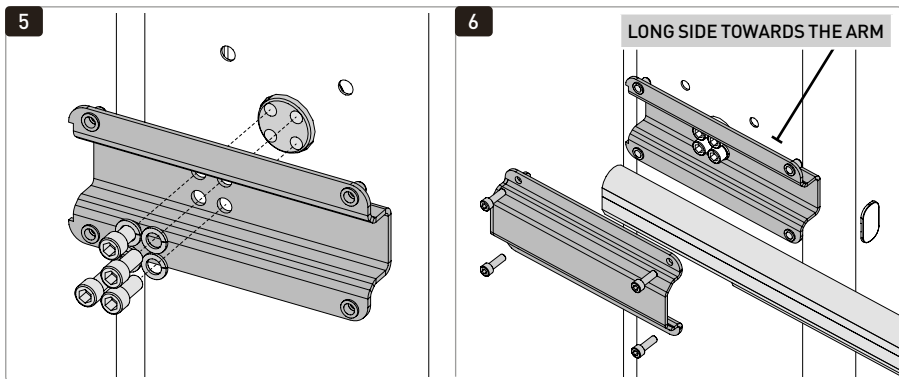

2.6.3 Elliptic Profile Boom

According to the desired net passage (PL):

1. Cut the boom, if necessary, to the specified length (PL+250mm).
2. Press-fit the bumpers.
3. Cut the bumpers, if necessary, to the specified length (PL+70mm).
4. Secure the end cap using the corresponding 4.8x16 TYPE-C screws.

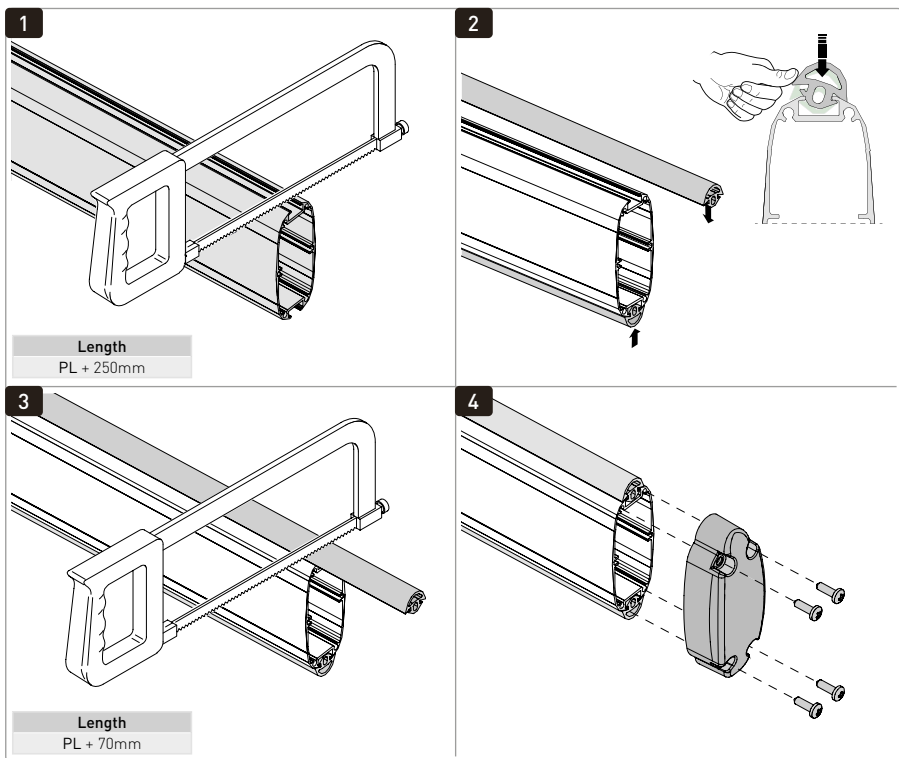

IP2458EN

5. Position the rear clamp, aligning it with the threaded holes on the drive shaft and, using the M12_R120 washers, fasten it with the four M12x25 screws.
6. Insert the fixing tabs into the boom, sliding them into their respective seats.
7. Secure the front clamp to the boom by tightening the four M6x10 screws onto the fixing tabs.
8. Fasten the assembly to the rear clamp, in the correct position, using the four M8x25 screws.

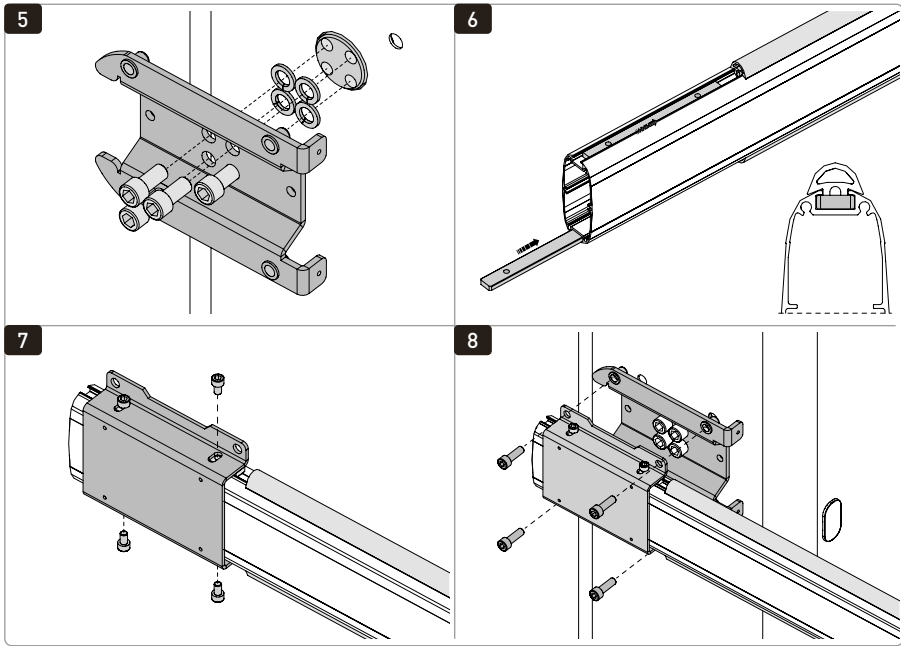

9. Insert the outer cover, matching the centering fins with the edges of the clamp.
10. Hook the closing cover by carefully inserting the tabs into the appropriate slots until fully engaged, then tighten the two 4,2x9,5 screws.

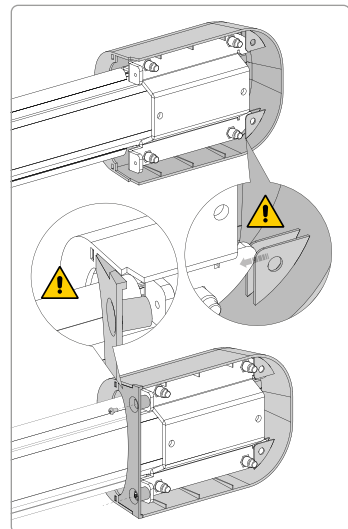
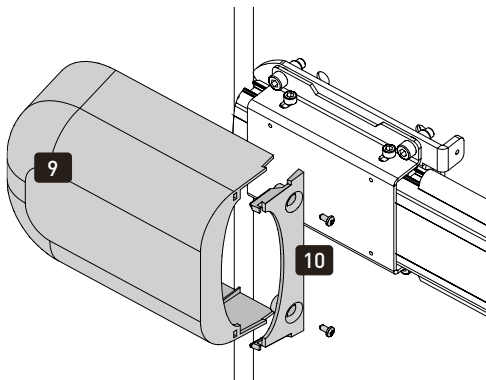

2.7 SPRING INSTALLATION

Carry out the manual release of the barrier • Lengthen the rod or the spring by manually unscrewing it to facilitate the operation • Attach the spring **1** to the tie rod and the appropriate slot on the base of the barrier body, in the correct position, based on the chosen opening direction (X/Y) • Align the rod with the appropriate hole on the rocker lever, insert the bushing **2** and fasten it using the M10x45 screw with thread-locker **3**, tightening firmly **4**.

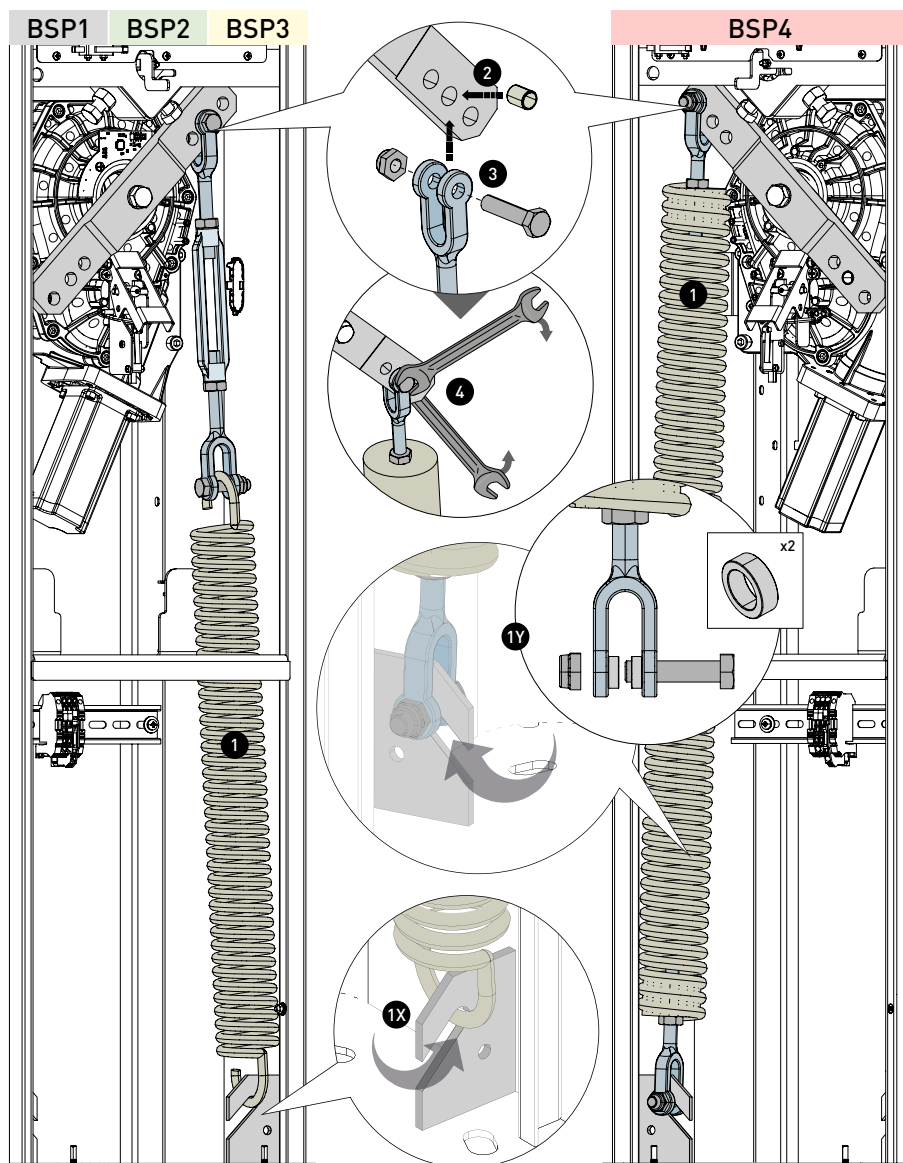

2.7.1 BALANCING



Loosen the locking nuts on the rod **A** • By manually screwing in the rod **B** (BSP1/2/3) or the spring **C** (BSP4), adjust the spring tension and balance the boom in a position between 5° and 30° from the ground: the boom is balanced when it maintains its position.

- If the boom tends to open, the rod must be lengthened.
- If the boom tends to close, the rod must be shortened.

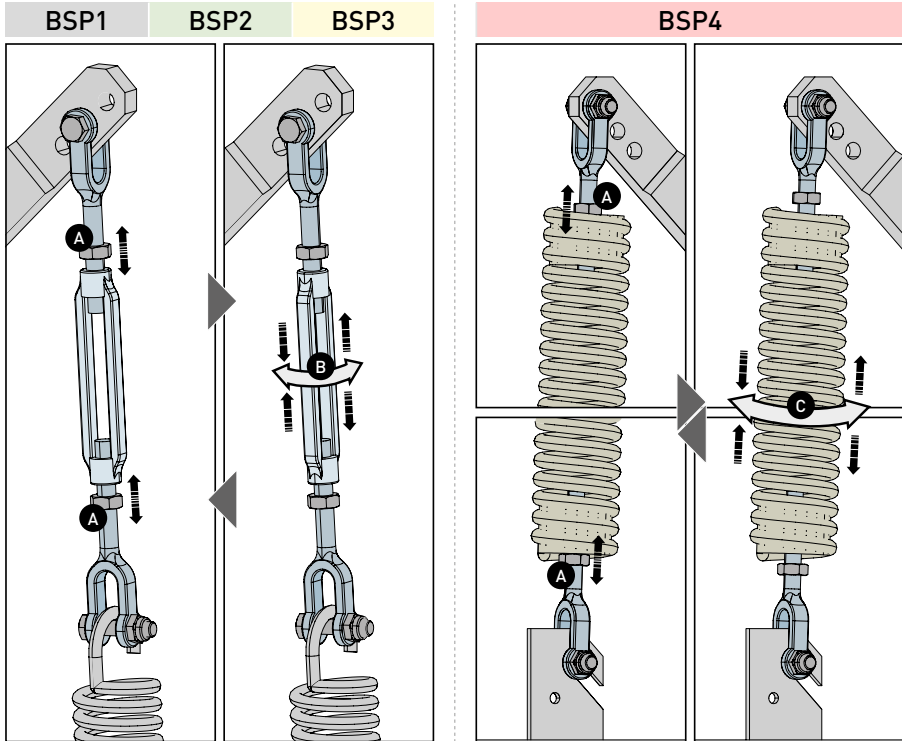
Repeat the adjustment, if necessary, until proper balancing of the boom is achieved • Tighten the rod's locking nuts **A**.



2.7.2 SPB - SPRING CONFIGURATION TABLES



PL (mm)			
2000 - 2499	BSP1	/	/
2500 - 3099	/	BSP1	/
3100 - 3299	/	/	BSP1
3300 - 3599	BSP2	/	/
3600 - 4000	/	BSP2	/







Respect the rocker-lever attachment holes indicated. Never use the motor force to support the weight of the boom. Any accessories installed on the boom must be mounted before balancing the boom and must be taken into account when selecting the appropriate balancing spring.

2.7.3 EPB - SPRING CONFIGURATION TABLES

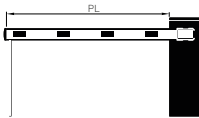



PL (mm)			
1600 - 1999	BSP1	/	/
2000 - 2399	/	BSP1	/
2400 - 2699	BSP2	/	/
2700 - 2999	/	BSP2	/
3000 - 3699	/	/	BSP2
3700 - 4499	/	BSP3	/
4500 - 5099	/	/	BSP3
5100 - 5699	/	BSP4	/
5700 - 6000	/	/	BSP4



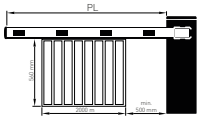

PL (mm)			
1900 - 2099	/	BSP1	/
2100 - 2399	/	/	BSP1
2400 - 2599	BSP2	/	/
2600 - 2899	/	BSP2	/
2900 - 3499	/	/	BSP2
3500 - 4299	/	BSP3	/
4300 - 4999	/	/	BSP3
5000 - 5199	/	BSP4	/
5200 - 6000	/	/	BSP4

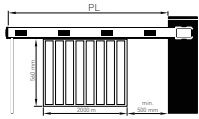

PL (mm)			
2500 - 2599	BSP2	/	/
2600 - 3199	/	BSP2	/
3200 - 3699	BSP2	/	BSP2
3700 - 4399	/	BSP2	/
4400 - 4499	/	/	BSP3
4500 - 5000	/	BSP4*	/





PL (mm)			
2700 - 2799	/	BSP2	/
2800 - 3199	/	/	BSP2
3200 - 3899	/	BSP3	/
3900 - 4399	/	/	BSP3
4400 - 4499	/	BSP4*	/
4500 - 5000	/	/	BSP4*

BSP4* - Use 2 aluminum fences BALSJK20.

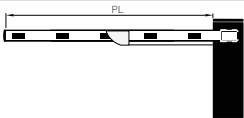
BSP4* - Use 2 aluminum fences BALSJK20.



PL (mm)			
2000 - 2499	BSP2	/	/
2500 - 3500	/	BSP2	/
3600 - 4199	/	BSP3	/
4200 - 5000	/	/	BSP3

*2000 - 3500 → L1 = 1200 mm - Hmax = 2100 mm

*3600 - 5000 → L1 = 2100 mm - Hmax = 3000 mm

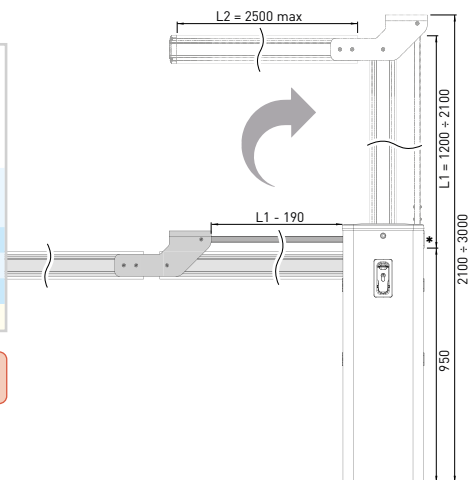

2.8 ADJUSTMENT OF MECHANICAL LIMIT STOPS

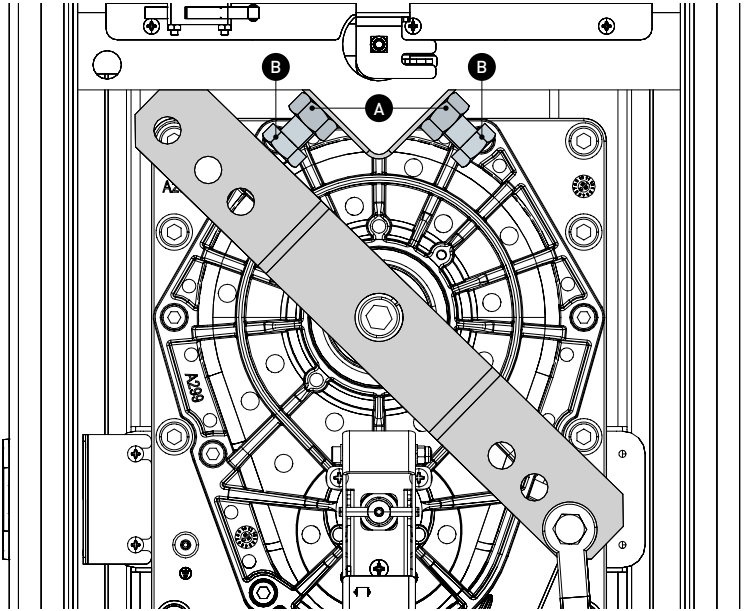

The inertial movement of the arm after stopping the motor is blocked using two adjustable mechanical stops up against the anchoring lever.

Perform the following operations for their safe adjustment:

- Perform the internal manual release  of the barrier (ref. paragraph 12.3);
- Simultaneously loosen the lock nut **A** and the screw **B**;
- Hold the lock nut **A** still and manually adjust the stop with the screw **B**;
- Lock the lock nut **A** and tighten the screw **B**;
- Check the correct adjustment of the limit switch.

If necessary, repeat the sequence.

It is possible to intervene on the limit switches to adjust the horizontality or verticality of the arm, depending on the chosen opening direction (ref. paragraph 2.5).

It is suggested to keep the arm parallel to the road surface when it is in the closed position and at about 90° when it is in the open position.

3. ELECTRICAL CONNECTIONS

 Before connecting the power supply, make sure the plate data correspond to those of the mains power supply. An omnipolar disconnection switch with a contact opening distance of at least 3 mm must be fitted on the mains supply. Check there is an adequate residual current circuit breaker and overcurrent cut-out upstream of the electrical system. Connection to the mains power supply, in the section outside the automation, is made on an independent channel and separated from the connections to the control and safety devices. The channel must penetrate the automation through the holes on the base plate at least 50 mm. Make sure there are no sharp edges that may damage the power supply cable.

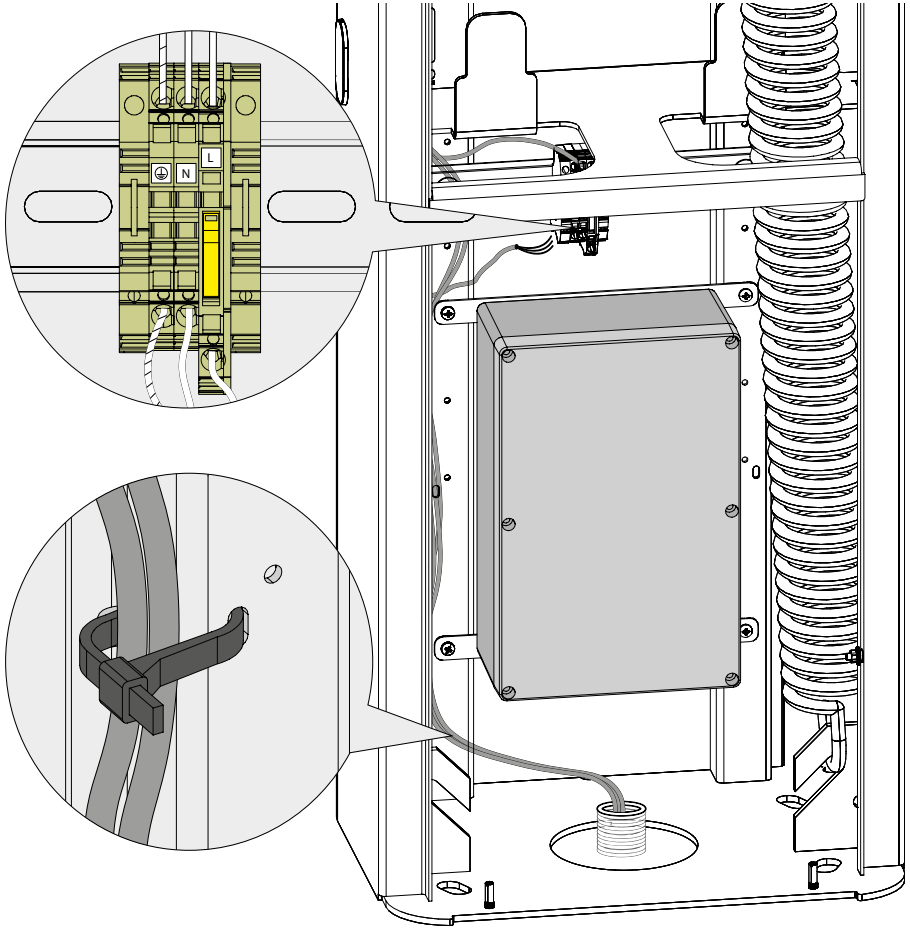

IP2458EN



Make sure that the mains connection cables, any other low voltage cables (120 Vac - 230 Vac), as well as the extra-low voltage accessory connection cables in the portion located inside the product, are kept well separated.

Use a H05RN-F 3G1.5 type electric cable and connect it to the terminals L (brown) and N (blue) inside the automation. Connect the earth wire (⊕) (yellow/green) to the appropriate terminal.

MORSETTI CON SISTEMA DI CONNESSIONE A MOLLA AUTOBLOCCANTE

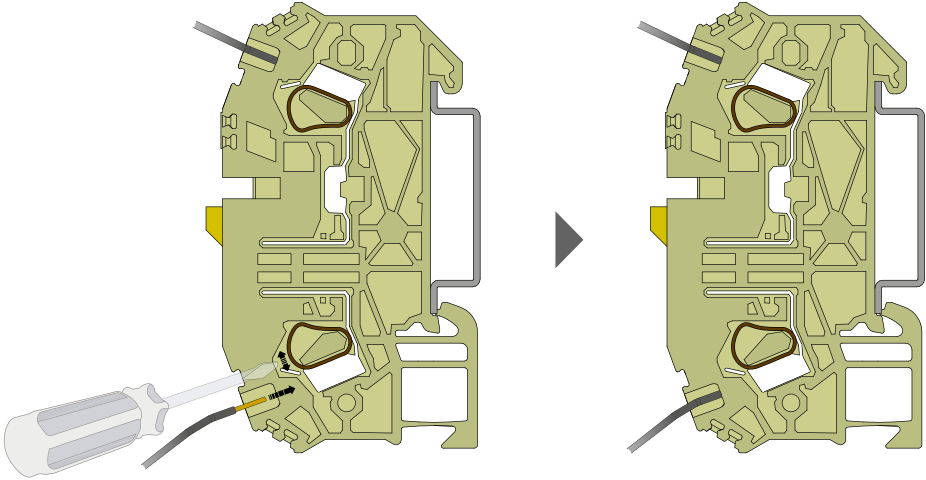

- Remove a portion of the insulation sheath from the conductor to the length specified by the manufacturer (usually 8–12 mm).
- Insert the appropriate tool and open the self-locking spring connection system.
- Insert the conductor into the terminal block until it reaches the stop.
- Check that the conductor is properly secured (pull gently).

It is possible to disconnect the phase cable L (brown) using the dedicated switch on the terminal block.

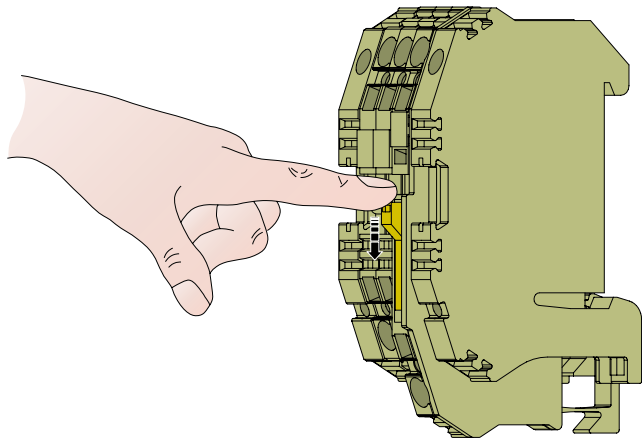

4. LCU55 BOARD

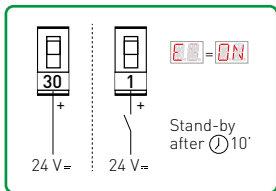
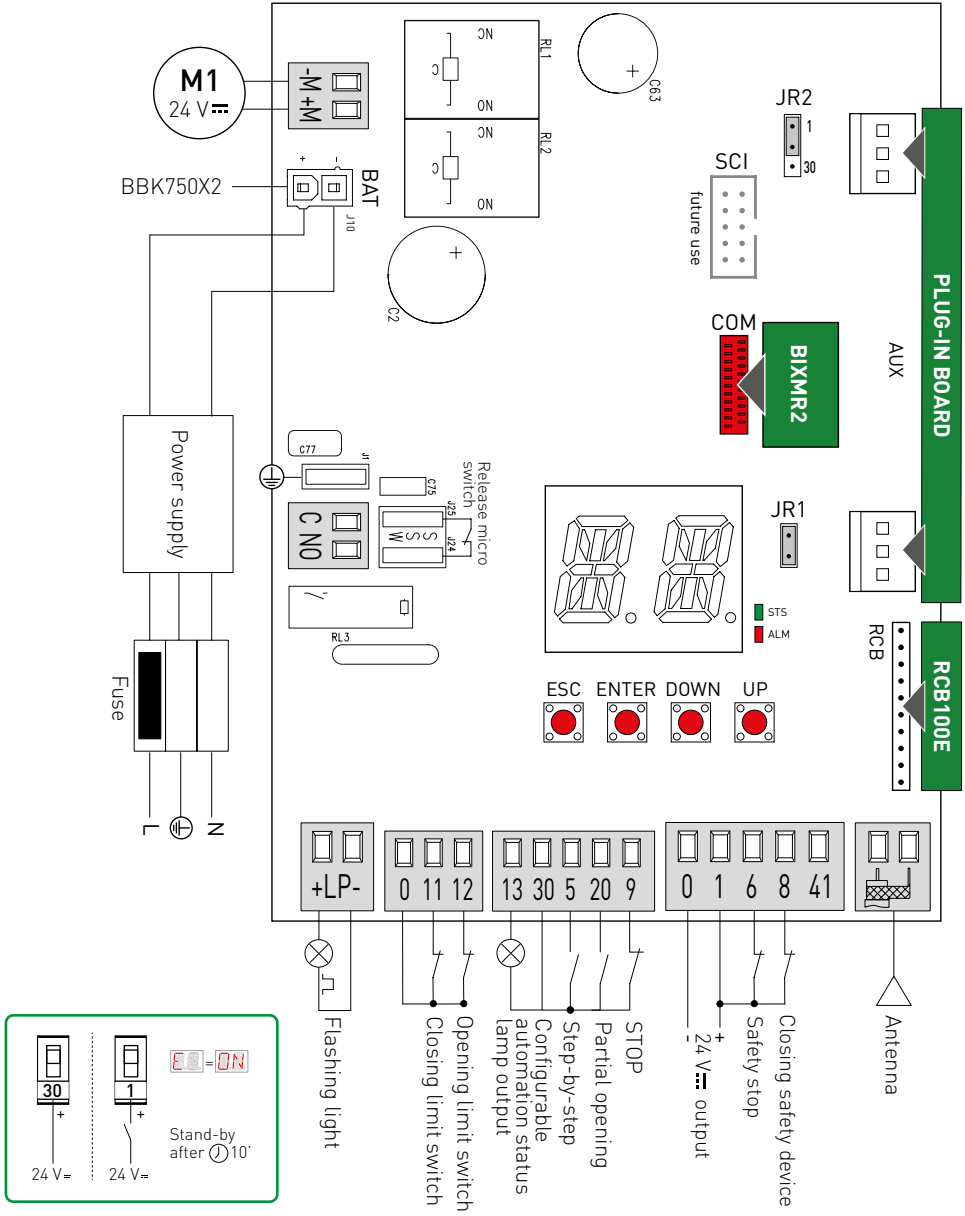



! Always respect the L-N polarity in the connection to the mains and close all unused terminals.

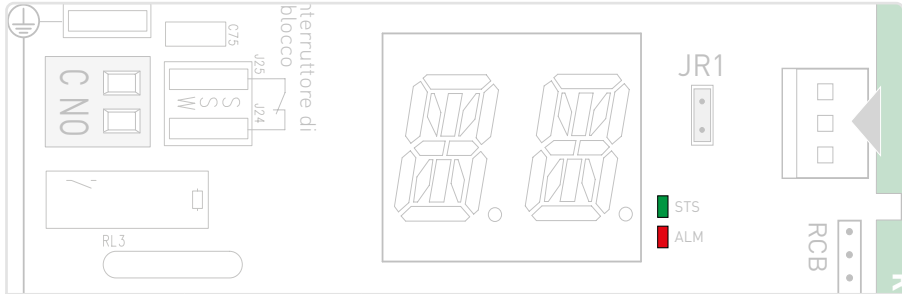

N3872PI



4.1 LED SIGNALS



Red LED 	Green LED 	Description
OFF	OFF	Board off or not working.
1 flash every second	OFF	LCU board on and working. RCB board (radio/BLE/WiFi) absent or not working.
OFF	1 flash every second	LCU board on and working. RCB50E board (radio) present and working.
OFF	2 flashes every second	LCU board on and working. RCB100E board (radio/BLE) present and working
OFF	3 flashes every second	LCU board on and working. RCB200E board (WiFi) on SCI present and working
OFF	4 flashes every second	LCU board on and working. RCB50E (Radio) + RCB200E (WiFi) board present and working
OFF	5 flashes every second	LCU board on and working. RCB100E board (Radio/BLE) + RCB200E (WiFi) present and working

4.2 JUMPER SETTINGS

Jumper	Description	OFF 	ON 
JR1	Display mode selection.	Display mode. Only the values and parameters present can be displayed.	Maintenance mode. Only the values and parameters present can be displayed and modified. Activated maintenance mode is indicated by the permanent switching on of the right-hand point on the display.

Jumper	Description		
JR2	Selection of power supply - auxiliary board.	AUX1 powered from 0-1 (default). With ES → ON it turns off during power saving mode.	AUX1 powered from 0-30. Always supplied.

5. COMMANDS AND SAFETY DEVICES



Terminal 30 (common positive for controls) has the same functions as terminal 1 and consequently, the commands displayed on the display are indicated with **I-3**, **I-4**, **I-5**, etc. It is different from terminal 1, however, because of the maximum current that it can deliver and is also active with the control panel in standby **ES** → **ON**. Create a jumper for all NC contacts if not used, or deactivate them through the relevant menu. Terminals with the same number are the same.





5.1 INPUTS

Function	Command	Description
NO		<p>When selecting IO → TS → I-5, the closure of the contact activates a sequential opening or closing operation: OPENING → STOP → CLOSING → OPENING.</p> <p> If automatic closing is enabled, the stop mode is selected via OM → SS.</p> <p>The "opening-stop-closing-opening" sequence can be changed to "opening-stop-closing-stop-opening" by selecting OM → PP.</p>
		<p>Selecting IO → TS → I-3, the closure of the contact activates an opening operation</p>
NC		<p>The opening of the safety contact causes the current operation to stop. If IO → R9 → 9P, automatic closing is disabled when contact 30-9 closes. If IO → R9 → 9T, automatic closing is activated when contact 30-9 closes.</p> <p> The flashing light blinks.</p>
NO		<p>The closure of the contact activates a partial opening operation. Once the automation stops, the partial opening command performs the opposite operation to the one performed before the stop.</p>
NC		<p>Selecting IO → 20 → I-2, the permanent closure of the contact enables automatic closing if OM → AC → I-2.</p>

5.2 SAFETY INPUTS



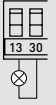

Function	Command	Description
		<p>Place the GOPAVRS device in its seat for AUX plug-in cards. To activate the safety test, configure parameters IO → DB and IO → DB. If the test fails, an alarm message appears on the display.</p>
NO		<p>Selecting IO → 64 → I-4, the closure of the contact activates a closing operation.</p>
NC		<p>Selecting IO → 64 → I-6, the opening of the safety contact stops and prevents any movement.</p> <p> To set different safety contact functions, refer to the settings of parameter IO → SM.</p>
NC		<p>The opening of the safety contact triggers a reversal of the movement (reopening) during the closing operation.</p> <p>Selection IO → 50 → DN, with the automation idle (gate closed or partially open), prevents any operation.</p> <p>Selection IO → 50 → DF, with the automation idle (gate closed or partially open) it is possible to activate the opening operation.</p>
NC		<p>The opening of the safety contact stops and prevents any movement.</p> <p> During the closing operation, the opening of the safety contact stops and reverses the movement. During the opening operation, the opening of the safety contact stops the movement.</p>

5.3 OUTPUTS AND ACCESSORIES

Function	Output	Accessories	Description
Accessories power supply		24V \approx	Output for powering external accessories. Accessories connected to this output will be switched off when ES \rightarrow ON (after 10 minutes).  The maximum absorption is the sum of all terminals 1.
Accessories power supply		24V \approx	Output for powering external accessories. All accessories connected to this output will remain powered when ES \rightarrow ON
Output configurable		24V \approx 2W 0.1A Max	Output 30-13 is factory-configured 13 \rightarrow 06 as an open barrier proportional indicator. To modify the operating mode of output 13, refer to selection 10 \rightarrow 13 .  If connecting larger loads, it is recommended to use an interface relay with an external power supply (ex. EL lock).

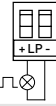
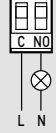

The total current supplied by outputs 24 V 1, 13 and 30 must not exceed **0.5 A**.

Output configurable		24V \approx 24W	Factory configured output LP as flashing ON-OFF LP \rightarrow 03 . The preflashing settings can be selected from the menu DM \rightarrow W0 and/or DM \rightarrow WC . To modify the operating mode of the LP output, refer to the selection 10 \rightarrow LP .
Output configurable		230V~ 2A Max	E' possibile collegare in serie al contatto NO un dispositivo esterno. Per modificare la modalità di funzionamento dell'uscita C-NO fare riferimento alla selezione 10 \rightarrow 63 . Factory configured output 10 \rightarrow 63 \rightarrow 00 as courtesy light.  The output does not supply power; it requires an external power source to drive the load.
Radio antenna			433 MHz - 868 MHz Use an RG-58 coaxial cable (50 Ω) to connect an external antenna (ref. GOL148REA)
Seat for plugin accessories	AUX	BIXR2 BIXPR2 BIXLR42 LAB9 LAN7S GOPAVRS	The action of the control card can be selected by selecting 10 \rightarrow AM . When using slot-in radio boards, remove the RX module. The display will show RK .
Radio receiver module			RCB100E radio receiver module (standard) configurable from the control panel: - 433.92 MHz (RO \rightarrow F0 \rightarrow 43) - default - 868.35 MHz (RO \rightarrow F0 \rightarrow 06) RCB50E compatible radio receiver module (option).
Radio control memory module		BIXMR2	This allows the functioning configurations to be saved using the function DF \rightarrow 5K . Saved configurations can be recalled using the function DF \rightarrow RC . The storage module allows the remote controls to be stored. If the control panel is replaced, the storage module being used can be inserted in the new control panel.



The storage module must be inserted and removed with the power supply disconnected, and paying attention to the positioning direction.

DC power supply		<p>Power supply: 36 V DC. With the power supply off, the power supply is reduced to 24 V DC in battery mode. The batteries are kept charged when the power supply is on. If the power supply is off, the panel is powered by the batteries until the power is re-established or until the battery voltage drops below the safety threshold. The control panel turns off in the last case. To check the voltage level of the batteries, refer to the menu BF → BL. (visible only in the absence of the mains and with batteries connected)</p> <p> The operating temperature of the rechargeable batteries is between +0°C and 40°C.</p>
------------------------	--	---

6. PRODUCT START-UP

- The display shows the central dot by default.
- Press the **ENTER** button.
- The display turns on for a functionality check.
- The **MAIN LEVEL** menu is displayed.

MAIN LEVEL

- Press **UP** or **DOWN** to scroll through the menu
- Press **ENTER** to access the **PARAMETERS LEVEL**
- Press **ESC** to exit a submenu

PARAMETERS LEVEL

- Press **UP** or **DOWN** to scroll through the parameters within the submenu
- To set a parameter, select the desired **VALUE** and save it by pressing **ENTER** for 2 seconds or with a prolonged double confirmation.

Pressing the keys can be quick (less than 2 s) or prolonged (longer than 2 s). Unless specified otherwise, quick pressure is intended. To confirm the setting of a parameter, prolonged pressing or prolonged double pressing is necessary.

To perform a quick configuration of the product, use the parameter menu **FU** (Frequent Use). In particular, configure the following parameters to ensure correct operation of the automation system:

6.1 SETTING THE OPENING DIRECTION

- Press **UP** or **DOWN** to scroll through the parameters within the submenu **DM**
- To set the correct opening direction, select the desired **VALUE** (**RT** / **LF**) and save it by pressing **ENTER** for 2 seconds.

If the direction is changed, the system will restart.

6.2 SETTING THE BOOM LENGTH



- Press **UP** or **DOWN** to scroll through the parameters within the submenu **LN**
- To set the correct opening direction, select the desired VALUE (**2M / 3M / 4M / 6M**) and save it by pressing **ENTER** for 2 seconds.

6.3 SETTING THE BOOM WEIGHT (installed accessories)



- Press **UP** or **DOWN** to scroll through the parameters within the submenu **WG**
- To set the correct opening direction, select the desired VALUE (**NO / 01 / 02 / 03**) and save it by pressing **ENTER** for 2 seconds.

6.4 START-UP TEST

Based on the selection of the two parameters **LN** and **WG** the system will optimize the stroke parameters (accelerations/decelerations, slowdowns, etc.) and will set the obstacle detection thresholds (**R1** and **R2**) as well as the release values for opening and closing (**B0** e **BC**). These latter values can still be adjusted according to installation requirements.

Continue from the menu **FU** and its related submenus, setting the parameter values according to the installation that has been carried out.

Once the configuration is completed, perform an initial calibration cycle of opening/closing (the speed will be reduced and a message will appear on the display: **M0**), followed by several additional cycles at the set speed (**VR / VC**).



Before closing the cabinet, always check the manual release. If it feels stiff, increase the release values **B0 / BC**. If the release movement of the arm during opening and/or closing is excessive, you can reduce the value for opening **B0** and/or closing **BC** while always ensuring that the release remains smooth.

The display shutdown procedure is as follows:



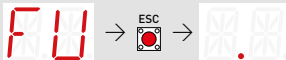



MAIN LEVEL



The display switches off automatically after 60 seconds of inactivity.













7. LCU55 PARAMETERS















7.1 MAIN LEVEL MENU

Display	Description
	Frequent use The menu allows you to manage the most frequently used parameters to customise the automation functions.
	Operating modes The menu allows you to set all the parameters used for the automation operating modes (type of automation installed, default settings, automatic closing, etc.)
	Stroke adjustment The menu allows you to set all movement parameters (opening/closing speed, slowdown positions, sensitivity of thrust on obstacles, etc.)
	Input/output configuration The menu allows you to set the automation input/output functions (selection of devices connected to the terminals, photocells, flashing light/electric lock setting, etc.)
	Radio operations and connectivity The menu allows you to manage all the parameters of the radio/wireless functions of the control unit
	Diagnostic functions The menu allows you to manage all the other parameters used for the additional services (diagnostic meters, FW update, energy saving, etc.).

Full menu

7.2 FREQUENT USE MENU

MAIN LEVEL	
	FU - Frequent use
PARAMETER LEVEL	
	AS - Automation selection
	DM - Opening direction
	LN - Boom length selection
	WG - Boom weight selection based on installed accessories
	EP - Encrypted radio-control transmission protocol settin (AES 128-bit and PROTECTED mode)
	SR - Radio control memorization
	RM - Radio receiver operating mode
	T5 - Terminal 5 operating mode
	AC - Automatic closing enable
	TC - Automatic closing time setting [s]
	RP - Partial opening adjustment [%]

	TP - Automatic closing time after partial opening [s]
	R1 - Obstacle force adjustment and opening current
	R2 - Obstacle force adjustment and closing current
	VA - Opening speed [cm/s]
	VC - Closing speed [cm/s]
	PP - Step-by-step sequence configuration
	R9 - Input 30-9 configuration
	D6 - Selection of the device connected to terminals 1-6 with safety test
	SM - Operating mode of terminals 1-6
	D8 - Selection of the device connected to terminals 1-8 with safety test
	S0 - Operating mode of terminals 1-8 when automation is stopped
	LP - output function +LP-
	FA - Opening limit-switch mode selection
	FC - Closing limit-switch mode selection

IP2458EN

7.3 COMPLETE MENU MAP

MAIN LEVEL	
OM	OM - Operating mode
PARAMETER LEVEL	
AS	AS - Automation selection
DM	DM - Opening direction
LN	LN - Boom length selection
WG	WG - Boom weight selection based on installed accessories
AC	AC - Automatic closing enable
TC	TC - Automatic closing time setting [s]
RP	RP - Partial opening adjustment [%]
TP	TP - Automatic closing time after partial opening [s]
PP	PP - Step-by-step sequence configuration
S9	S9 - STOP mode in the step-by-step sequence from terminal 1-5
SS	SS - Automation status at power-on
TS	TS - Automatic closing time reset after safety device release [%]
WO	WO - Opening pre-flashing time setting [s]
WC	WC - Closing pre-flashing time setting [s]
NI	NI - NIO anti-freeze system activation
TN	TN - NIO intervention temperature and automatic ramps
TH	TH - High-temperature protection enable
HF	HF - Heavy Traffic function
DS	DS - Display visualization mode
PS	PS - Default settings

RA	RA - Stroke adjustment
PARAMETER LEVEL	
VA	VA - Opening speed [cm/s]
VC	VC - Closing speed [cm/s]
R1	R1 - Obstacle force adjustment and opening current
R2	R2 - Obstacle force adjustment and closing current

DT	DT - Obstacle detection time adjustment
OB	OB - Opening slowdown distance [cm]
CB	CB - Closing slowdown distance [cm]
OO	OO - Opening obstacle detection threshold
OC	OC - Closing obstacle detection threshold
DO	DO - Opening end-stop disengagement adjustment [mm]
DC	DC - Closing end-stop disengagement adjustment [mm]
DE	DE - Safety edge disengagement adjustment [cm]
ST	ST - Starting boost time adjustment
OT	OT - Obstacle type selection

IO	IO - Input/output configuration
PARAMETER LEVEL	
FA	FA - Opening limit-switch mode selection
FC	FC - Closing limit-switch mode selection
R9	R9 - Input 30-9 configuration
T5	T5 - Terminal 5 operating mode
64	64 - Safety stop / closing command operating mode
AM	AM - AUX board operating mode
20	20 - Partial opening command on terminals 30-20
PT	PT - Fixed partial opening
D6	D6 - Selection of the device connected to terminals 1-6
SM	SM - Operating mode of terminals 1-6
D8	D8 - Selection of the device connected to terminals 1-8
S0	S0 - Operating mode of terminals 1-8 when open
68	68 - Selection of the device connected to terminals 1-6 and 1-8
LP	LP - output function +LP-
G3	G3 - relay output function G3







13	13 - output function 13
LU	LU - Courtesy light activation time [s]
LG	LG - Activation time of independently controlled light
BR	BR - Brightness level of courtesy light / LED strip
LR	LR - Electric lock release time
PV	PV - Solar panel power supply
ES	ES - Energy-saving mode
LB	LB - Low-battery warning
LL	LL - Voltage threshold for low-battery warning
BO	BO - Battery mode









WF	WF - Wi-Fi functionality setup
MA	MA - Access management mobile app

RO	RO - Radio operations and connectivity
↓	PARAMETER LEVEL
EP	EP - Encrypted message setup
SR	SR - Remote controls memorization
RM	RM - Radio receiver operation
TX	TX - Display of the number of memorized remote controls
MU	MU - Maximum number of remote controls storable in the integrated memory
ER	ER - Deletion of a remote control
EA	EA - Full memory wipe
C1	
C2	C1, C2, C3, C4 - Function selection: CH1, CH2, CH3, CH4 of the memorized remote control
C3	
C4	
RE	RE - Setup for opening memory via remote transmitter
MS	MS - Backward compatibility with older-generation remote controls
RK	RK - Menu navigation via keypad
FQ	FQ - Radio frequency selection
VL	VL - Vacation mode lock/unlock
BT	BT - Bluetooth® mode

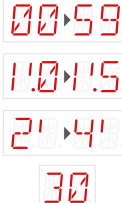
DF	DF - Diagnostic functions
↓	PARAMETER LEVEL
SP	SP - Password setup
CU	CU - Control board firmware version
UP	UP - Firmware update
AL	AL - Alarm counter
AH	AH - Alarm history
AR	AR - Alarm reset
CV	CV - Total number of cycles
CP	CP - Partial number of cycles
ZP	ZP - Reset of partial cycle counter
CA	CA - Maintenance alarm setting (factory default – alarm disabled: 0.0 00. 00)
OA	OA - Maintenance alarm mode display
CH	CH - Power-on hours
BH	BH - Battery-powered operating hours
SV	SV - Save configuration
RC	RC - Load configuration
RL	RL - Load last saved configuration
EU	EU - Clear user settings
IM	IM - Motor current display
TB	TB - Internal automation temperature display
TT	TT - Visualizzazione delle temperature max. e min. registrate
TF	TF - Limit switch test. Displays FA / FC (N.O./NO if not configured)
BL	BL - Battery voltage level display
EL	EL - Automation efficiency level
RD	RD - Reset factory settings

7.4 “FREQUENT USE” MENU – PARAMETER DESCRIPTION

FU - Frequent use		Available selections
Parameter	Description	
AS	<p>AS - Automation selection Allows the user to select the type of automation (factory-preset)</p> <ul style="list-style-type: none"> • NO - None • S4 - SPID40 • S6 - SPID60 • BX - BOX <p> The control board performs a reboot and a factory reset after selecting a new value.</p> <p> If a replacement control board is installed, the alarm M0 flashes on the display. In this condition, no operation is allowed. The parameter AS must be configured first. This procedure must be carried out by qualified personnel.</p>	<p>NO BX</p> <p>(SPID40) (SPID60)</p> <p>S4 S6</p>
DM	<p>DM - Opening direction</p> <ul style="list-style-type: none"> • RT - Right opening • LF - Left opening 	RT LF
LN	<p>LN - Boom length selection The selected value automatically configures the stroke parameters.</p> <ul style="list-style-type: none"> • 2M - between 0 and 2m • 3M - between 2m and 3m • 4M - between 3m and 4m • 6M - between 4m and 6m (SPID60 only) 	<p>2M 3M</p> <p>(SPID40) (SPID60)</p> <p>4M 6M</p>
WG	<p>WG - Selection of boom weight based on installed accessories</p> <ul style="list-style-type: none"> • NO - No accessory installed (default) • 01 - Mobile support or BFISE • 02 - Aluminum fence • 03 - Aluminum fence + Mobile support or BFISE 	NO 01 02 03
EP	<p>EP - Encrypted message setup for remote-control transmission (AES-128-bit mode and Protected mode) If the option to receive encrypted messages is enabled, the control panel will be compatible with “ENCRYPTED” or “Protected” type transmitters.</p> <ul style="list-style-type: none"> • 0N - Enabled • 0F - Disabled 	0N 0F
SR	<p>SR - Remote controls memorization</p> <p></p> <p>By pressing , the indicator begins to flash SR and the desired buttons can be associated. After OK, is displayed, the indicator continues to flash SR, allowing another button to be memorized. To exit, press  or  for 2 seconds to move to the next menu item.</p> <p> If the display shows a flashing SR, the remote control may already be memorized.</p>	
RM	<p>RM - Radio receiver operation This is the function associated with the radio command when only one channel is memorized (regardless of which one it is).</p> <ul style="list-style-type: none"> • 1-5 - Step-by-step • 1-3 - Opening 	1-5 1-3
T5	<p>T5 - Terminal 5 operating mode</p> <ul style="list-style-type: none"> • 1-5 - Step-by-step • 1-3 - Opening 	1-5 1-3

FU	AC	AC - Automatic closing enable <ul style="list-style-type: none"> • 0F - Disabled • 0N - Enabled • 1-2 - Depends on the status of terminal 20 (the parameter 20 must be set to 1-2) 	
	TC	TC - Automatic closing time setting [s] The adjustment is performed with different sensitivity intervals: <ul style="list-style-type: none"> • From 0" to 59" steps of 1 second • From 1'0" to 1'5" steps of 10 second During this range, the display will show values such as: <ul style="list-style-type: none"> - 1'1 → 1 minute and 10 seconds - ... - 1'5 → 1 minute and 50 seconds • From 2' to 4' steps of 1 minute 	
	RP	RP - Partial opening adjustment [%] Adjusts the percentage of movement relative to the system's full opening. <ul style="list-style-type: none"> • From 10 to 99 % in 1% increments 	
	TP	TP - Set automatic closing time after partial opening [s] The adjustment is performed with different sensitivity intervals: <ul style="list-style-type: none"> • From 0" to 59" steps of 1 second • From 1'0" to 1'5" steps of 10 second During this range, the display will show values such as: <ul style="list-style-type: none"> - 1'1 → 1 minute and 10 seconds - ... - 1'5 → 1 minute and 50 seconds • From 2' to 4' steps of 1 minute 	
	R1	R1 - Adjustment of obstacle-force threshold and motor current during opening [%] The control board is equipped with a safety device that, in the presence of an obstacle: <ul style="list-style-type: none"> - stops the movement, and if outside the obstacle-detection limit area, performs a disengagement maneuver. <div style="border: 1px solid blue; padding: 5px; margin: 5px 0;">  The obstacle detection limit in opening is determined by the type of limit switch installed; if no limit switch is present, it is determined according to the selected setting RA → 00. </div> <ul style="list-style-type: none"> • 00 - Minimum force (minimum current-delta for obstacle detection) • 99 - Maximum force (maximum current-delta for obstacle detection) The threshold is dynamically calculated as a delta based on the motor current measured during the opening cycle.	
	R2	R2 - Adjustment of obstacle-force threshold and motor current during closing [%] The control board is equipped with a safety device that, in the presence of an obstacle: <ul style="list-style-type: none"> - During closing, outside the obstacle-detection limit area, the movement is reversed; - During closing, inside the obstacle-detection limit area, the movement is stopped. <div style="border: 1px solid blue; padding: 5px; margin: 5px 0;">  The obstacle detection limit in closing is determined by the type of limit switch installed; if no limit switch is present, it is determined according to the selected setting RA → 00. </div> <ul style="list-style-type: none"> • 00 - Minimum force (minimum current-delta for obstacle detection) • 99 - Maximum force (maximum current-delta for obstacle detection) The threshold is dynamically calculated as a delta based on the motor current measured during the closing cycle.	
	VA	VA - Opening speed [V] <ul style="list-style-type: none"> • 01 - Slow • 02 - Normal (default) • 03 - Fast • 04 - Maximum speed 	

FU	VC	VC - Closing speed [V] <ul style="list-style-type: none"> • 01 - Slow • 02 - Normal (default) • 03 - Fast • 04 - Maximum speed <p> The speed values are automatically calculated based on the barrier configuration (LN and WG).</p>	01 02 03 04
R9		R9 - Operating mode of terminal 9 <ul style="list-style-type: none"> • NO - Disabled • 9P - Opening of the input activates a permanent stop • 9T - Opening of the input activates a temporary stop. When the contact closes, the automatic closing time is triggered, if enabled • HR - With the input open, the automation operates in hold-to-run mode 	NO 9P 9T HR
D6		D6 - Selection of the device connected to terminals 1–6 <ul style="list-style-type: none"> • NO - None • PH - Photocells • P41 - Photocells with safety test • SE - Safety edge (if the 1–6 contact opens, after stopping, a 10-cm disengagement is performed). • S41 - Safety edge with safety test (if the 1–6 contact opens, after stopping, a disengagement is performed with a duration depending on the selection RA → DE) 	NO PH P41 SE S41
SM		SM - Operating mode of terminals 1–6 <ul style="list-style-type: none"> • 00 - During movement, opening of the safety contact stops the motion (with disengagement if parameter D6 → SE / S41). • 01 - During movement, opening of the safety contact stops the motion (with disengagement if parameter D6 → SE / S41). Once the contact is closed again, the interrupted movement resumes. • 02 - During movement, opening of the safety contact stops the motion (with disengagement if parameter D6 → SE / S41). Once the contact is closed again, an opening cycle is performed. • 03 - During the closing cycle, opening of the safety contact reverses the movement. During the opening cycle, the safety device is ignored. • 04 - During the opening cycle, opening of the safety contact stops the movement (with disengagement if parameter D6 → SE / S41). When the contact closes again, the opening cycle resumes. During the closing cycle, the safety device is ignored. • 05 - During the closing cycle, opening of the safety contact stops and reverses the movement. During the opening cycle, opening of the safety contact stops the movement (with disengagement if parameter D6 → SE / S41). • 06 - During a movement, opening of the safety contact stops the motion. When the contact closes again, automatic closing is disabled. 	00 01 02 03 04 05 06
D8		D8 - Selection of the device connected to terminals 1–8 <ul style="list-style-type: none"> • NO - None • PH - Photocells • P41 - Photocells with safety test • SE - Safety edge (if the 1–8 contact opens, after stopping, a 10-cm disengagement is performed) • S41 - Safety edge with safety test (if the 1–8 contact opens, after stopping, a disengagement is performed with a duration depending on the selection RA → DE) 	NO PH P41 SE S41
S0		S0 - Operating mode of terminal 1–8 when open <ul style="list-style-type: none"> • ON - Enabled • OF - Disabled <p>If enabled (ON) when the automation is stopped (barrier closed or partially open), any movement is prevented.</p> <p>If enabled (OF) when the automation is stopped (barrier closed or partially open), an opening command is allowed.</p>	ON OF

FU FA	FA - Selection of the opening limit-switch mode <ul style="list-style-type: none"> • NO - None • SX - Stop limit switch (after activation, the boom stops moving) • PX - Proximity limit switch (after activation, the boom continues until it reaches the mechanical stop, and any obstacle is considered a stop point) 	NO SX PX
FC	FC - Selection of the closing limit-switch mode <ul style="list-style-type: none"> • NO - None • SX - Stop limit switch (after activation, the boom stops moving) • PX - Proximity limit switch (after activation, the boom continues until it reaches the mechanical stop, and any obstacle is considered a stop point) 	NO SX PX

7.5 FULL MENU – PARAMETER DESCRIPTION



Parameter	Description	Available selections
OM	OM - Operating mode The menu allows the management of all parameters used for the automation's operating modes (installed automation type, default settings, automatic closing, etc.).	
AS	AS - Automation selection Allows the user to select the type of automation (factory-preset) <ul style="list-style-type: none"> • NO - None • S4 - SPID40 • S6 - SPID60 • BX - BOX <div style="border: 1px solid blue; padding: 2px; margin: 5px 0;"> The control board performs a reboot and a factory reset after selecting a new value. </div> <div style="border: 1px solid yellow; padding: 2px; margin: 5px 0;"> If a replacement control board is installed, the alarm M0 flashes on the display. In this condition, no operation is allowed. The parameter AS must be configured first. This procedure must be carried out by qualified personnel. </div>	NO BX SPID40 SPID60 S4 S6
DM	DM - Opening direction <ul style="list-style-type: none"> • RT - Right opening • LF - Left opening 	RT LF
LN	LN - Boom length selection The selected value automatically configures the stroke parameters. <ul style="list-style-type: none"> • 2M - between 0 and 2m • 3M - between 2m and 3m • 4M - between 3m and 4m • 6M - between 4m and 6m (SPID60 only) 	2M 3M SPID40 SPID60 4M 6M
WG	WG - Selection of boom weight based on installed accessories <ul style="list-style-type: none"> • NO - No accessory installed (default) • 01 - Mobile support or BFISE • 02 - Aluminum fence • 03 - Aluminum fence + Mobile support or BFISE 	NO 01 02 03
AC	AC - Automatic closing enable <ul style="list-style-type: none"> • 0F - Disabled • 0N - Enabled • 1-2 - Depends on the status of terminal 20 (the parameter 20 must be set to 1-2) 	0F 1-2 0N
TC	TC - Automatic closing time setting [s] The adjustment is performed with different sensitivity intervals: <ul style="list-style-type: none"> • From 0" to 59" steps of 1 second • From 1'0" to 1'5" steps of 10 second During this range, the display will show values such as: <ul style="list-style-type: none"> - 1'1" → 1 minute and 10 seconds - ... - 1'5" → 1 minute and 50 seconds • From 2' to 4' steps of 1 minute	00 ▶ 59 1'0 ▶ 1'5 2' ▶ 4' 1'0

OM

RP	RP - Partial opening adjustment [%] Adjusts the percentage of movement relative to the system's full opening. • From 10 to 99% in 1% increments	10▶99 30
TP	TP - Set automatic closing time after partial opening [s] The adjustment is performed with different sensitivity intervals: • From 0" to 59" steps of 1 second • From 1'0 to 1'5 steps of 10 second During this range, the display will show values such as: - 1'1 → 1 minute and 10 seconds - ... - 1'5 → 1 minute and 50 seconds • From 2' to 4' steps of 1 minute	00▶59 11▶15 21▶41 30
PP	PP - Step-by-step sequence configuration • 00 - Open-Stop-Close-Open • 01 - Open-Stop-Close-Stop-Open	00 01
S9	S9 - STOP mode in the step-by-step sequence from terminal 1-5 ON - Permanent OF - Temporary	ON OF
SS	SS - Automation state selection at power-up OP - Open CL - Closed Indicates how the control panel considers the automation at power-up or after a POWER RESET command.	OP CL
TS	TS - Set automatic closing time renewal after safety release [%] • From 0 to 99% in 1% increments The countdown starts when the barrier is fully open (and the closing operation is carried out even if automatic closing (AC) is disabled). <div style="border: 1px solid black; padding: 2px; background-color: #ffffcc;"> Automatic closing is not disabled after the third consecutive direction reversal. </div>	00▶99
WO	WO - Opening pre-flashing time setting [s] Adjusts the advance time between the activation of the flashing light and the start of the opening movement triggered by a voluntary command. • From 0" to 5" in 1-second increments.	00▶05
WC	WC - Closing pre-flashing time setting [s] Adjusts the advance time between the activation of the flashing light and the start of the closing movement triggered by a voluntary command. • From 0" to 5" in 1-second increments.	00▶05
NI	NI - NIO electronic anti-freeze system enable • ON - Enabled • OF - Disabled When enabled (ON), it maintains motor efficiency even at low ambient temperatures. <div style="border: 1px solid black; padding: 2px; background-color: #e0f0ff;"> For correct operation, the control panel must be at the same ambient temperature as the motors. </div> The intervention temperature HS can be set by selecting OM → TN.	ON OF
TN	TN - Intervention temperature setting for the NIO electronic anti-freeze system and automatic ramps HS [°C] The value does not refer to the ambient temperature but to the internal temperature of the control panel.	-9▶50 20
TH	TH - High-temperature protection enable • ON - Abilitato • OF - Disabilitato When enabled (ON), upon reaching the maximum allowable internal temperature of the control panel (80°C), the maximum automatic-closing time is applied to allow the system to return to acceptable operating temperatures.	ON OF



<p>HF</p>	<p>HF - Heavy Traffic function</p> <ul style="list-style-type: none"> • 0N - Enabled • 0F - Disabled <p>When enabled, the automatic-closing time is automatically set to 3 minutes if several consecutive operations occur due to frequent opening requests (e.g., during peak hours in residential or condominium environments). This reduces user waiting times while also limiting motor overheating and wear.</p>	<p>0N 0F</p>
<p>DS</p>	<p>DS - Display mode setting</p> <ul style="list-style-type: none"> • 00 - No display • 01 - Commands, safety devices, and radio test. Displays the automatic-closing countdown. <p>i Setting 01 allows the display of radio-transmission reception for range-verification tests (RX and NX – see section 16.2).</p>	<p>00 01</p>
<p>PS</p>	<p>PS - Default settings Used to load the default settings for a number of parameters:</p> <p>DF DF- Default configuration</p> <ul style="list-style-type: none"> • AC - Automatic closing enable 0N • TC - Automatic closing time setting 11 • T5 - Operating mode of terminal 5 1-5 • RM - Radio receiver operation 1-5 • AM - Operation of the AUX plug-in control board 1-5 • SS - Automation state selection at power-up CL <p>H0 H0 - Default configuration for residential use 0</p> <ul style="list-style-type: none"> • AC - Automatic closing enable 1-2 • T5 - Operating mode of terminal 5 1-5 • RM - Radio receiver operation 1-5 • AM - Operation of the AUX plug-in control board 1-5 • SS - Automation state selection at power-up 0P <p>H1 H1 - Configurazione predefinita uso residenziale 1</p> <ul style="list-style-type: none"> • AC - Automatic closing enable 0N • TC - Automatic closing time setting 11 • T5 - Operating mode of terminal 5 1-5 • RM - Radio receiver operation 1-5 • AM - Operation of the AUX plug-in control board 1-5 • SS - Automation state selection at power-up CL <p>C0 C0 - Configurazione predefinita uso condominiale 0</p> <ul style="list-style-type: none"> • AC - Automatic closing enable 0N • TC - Automatic closing time setting 11 • T5 - Operating mode of terminal 5 1-3 • RM - Radio receiver operation 1-3 • AM - Operation of the AUX plug-in control board 1-3 • SS - Automation state selection at power-up CL 	<p>DF</p> <p>H0</p> <p>H1</p> <p>C0</p>



RA - Stroke adjustment

The menu allows you to adjust all movement parameters (opening/closing speed, slow-down positions, sensitivity to obstacle thrust, etc.)

Parameter	Description	Selections available
 VA	VA - Opening speed [V] <ul style="list-style-type: none"> 01 - Slow 02 - Normal (default) 03 - Fast 04 - Maximum speed <p> The speed values are automatically calculated based on the barrier configuration (LN and WG).</p>	
 VC	VC - Closing speed [V] <ul style="list-style-type: none"> 01 - Slow 02 - Normal (default) 03 - Fast 04 - Maximum speed <p> The speed values are automatically calculated based on the barrier configuration (LN and WG).</p>	
 R1	R1 - Adjustment of obstacle-force threshold and motor current during opening [%] <p>The control board is equipped with a safety device that, in the presence of an obstacle:</p> <ul style="list-style-type: none"> - stops the movement, and if outside the obstacle-detection limit area, performs a disengagement maneuver. <p> The obstacle detection limit in opening is determined by the type of limit switch installed; if no limit switch is present, it is determined according to the selected setting RA → 00.</p> <ul style="list-style-type: none"> 00 - Minimum force (minimum current-delta for obstacle detection) 99 - Maximum force (maximum current-delta for obstacle detection) <p>The threshold is dynamically calculated as a delta based on the motor current measured during the opening cycle.</p>	
 R2	R2 - Adjustment of obstacle-force threshold and motor current during closing [%] <p>The control board is equipped with a safety device that, in the presence of an obstacle:</p> <ul style="list-style-type: none"> - During closing, outside the obstacle-detection limit area, the movement is reversed; - During closing, inside the obstacle-detection limit area, the movement is stopped. <p> The obstacle detection limit in closing is determined by the type of limit switch installed; if no limit switch is present, it is determined according to the selected setting RA → 00.</p> <ul style="list-style-type: none"> 00 - Minimum force (minimum current-delta for obstacle detection) 99 - Maximum force (maximum current-delta for obstacle detection) <p>The threshold is dynamically calculated as a delta based on the motor current measured during the closing cycle.</p>	
 DT	DT - Obstacle recognition time adjustment [s/100] <ul style="list-style-type: none"> from 10 to 60 s/100 in steps of 1 s/100 <p> The parameter is adjusted in hundredths of a second.</p>	
 OB	OB - Adjustment of slowdown distance during opening [%] <p>It indicates the deceleration distance before reaching the opening position.</p> <ul style="list-style-type: none"> from 10 to 50 The value is expressed as a percentage of the total stroke. <p> The value is automatically set whenever the barrier configuration is changed (LN and WG).</p>	



	<p>CB - Adjustment of slowdown distance during closing [%] t indicates the deceleration distance before reaching the closing position. • from 10 to 50 The value is expressed as a percentage of the total stroke. The value is automatically set whenever the barrier configuration is changed (LN and WG).</p>	<p>10 ▶ 50 <u>30</u></p>
	<p>OO - Obstacle detection limit during opening [%] Sets the obstacle detection range that triggers a reversal of movement. Beyond this limit, any obstacle is interpreted as a mechanical end-of-stroke stop (with no reversal). • from 02 to 50 The value is expressed as a percentage of the total stroke. The value is automatically set whenever the barrier configuration is changed (LN and WG).</p>	<p>02 ▶ 50 <u>10</u></p>
	<p>OC - Obstacle detection limit during closing [%] Sets the obstacle detection range that triggers a reversal of movement. Beyond this limit, any obstacle is interpreted as a mechanical end-of-stroke stop (with no reversal). • from 05 to 99 The value is expressed as a percentage of the total stroke. The value is automatically set whenever the barrier configuration is changed (LN and WG).</p>	<p>05 ▶ 99 <u>07</u></p>
	<p>DO - Space of disengagement at the stop during opening [degrees] Regulates the space of disengagement at the mechanical opening stop. • from 2 to 99 degrees with intervals of 1 degree The value is automatically set whenever the barrier configuration is changed (LN and WG). Check the manual release before closing the cabinet.</p>	<p>02 ▶ 99 <u>15</u> (SPID40B) 20 (SPID60B)</p>
	<p>DC - Space of disengagement at the stop during closing [degrees] Regulates the space of disengagement at the mechanical closing stop. • from 2 to 99 degrees with intervals of 1 degree The value is automatically set whenever the barrier configuration is changed (LN and WG). Check the manual release before closing the cabinet.</p>	<p>02 ▶ 99 <u>12</u> (SPID40B) 20 (SPID60B)</p>
	<p>DE - Obstacle disengagement space in opening [degrees] Adjusts the disengagement space in case an obstacle is detected during opening. • 00 - Disabled • 99 - Maximum value</p>	<p>00 ▶ 99 <u>30</u></p>
	<p>ST - Adjustment of start time [s] • from 0.5 to 3.0s with intervals of 0.1 s During start-up, the obstacle detection function is inhibited.</p>	<p>0.5 ▶ 3.0 <u>0.8</u></p>
	<p>OT - Selection of type of obstacle • 00 - Overcurrent or boom locked • 01 - Overcurrent only • 02 - Locked arm only</p>	<p>00 01 02 <u>01</u></p>



IO - Input/Output configuration

The menu allows you to configure the automation input/output functions.

Parameter	Description	Available selections
FA	FA - Selection of the opening limit-switch mode <ul style="list-style-type: none"> • NO - None • SX - Stop limit switch (after activation, the boom stops moving) • PX - Proximity limit switch (after activation, the boom continues until it reaches the mechanical stop, and any obstacle is considered a stop point) 	NO SX PX
FC	FC - Selection of the closing limit-switch mode <ul style="list-style-type: none"> • NO - None • SX - Stop limit switch (after activation, the boom stops moving) • PX - Proximity limit switch (after activation, the boom continues until it reaches the mechanical stop, and any obstacle is considered a stop point) 	NO SX PX
R9	R9 - Operating mode of terminal 9 <ul style="list-style-type: none"> • NO - Disabled • 9P - Opening of the input activates a permanent stop • 9T - Opening of the input activates a temporary stop. When the contact closes, the automatic closing time is triggered, if enabled • HR - With the input open, the automation operates in hold-to-run mode 	NO 9P 9T HR
T5	T5 - Terminal 5 operating mode This parameter is associated with the functionality of terminal 30-5 <ul style="list-style-type: none"> • 1-5 - Step-by-step • 1-3 - Opening 	1-5 1-3
64	64 - Functioning of the safety stop/close command <ul style="list-style-type: none"> • 1-4 - Closing. NO contact • 1-6 - Safety stop. NC contact 	1-4 1-6
AM	AM - Operation of AUX plug-in control card <ul style="list-style-type: none"> • 1-5 - Step-by-step • 1-3 - Opening 	1-5 1-3
20	20 - Partial opening command (terminal 30-20) <ul style="list-style-type: none"> • P3 - Partial opening command • 1-2 - Enabling automatic closing • 1-4 - Closing. NO contact 	P3 1-2 1-4
PT	PT - Fixed partial opening <ul style="list-style-type: none"> • ON - Enabled • OF - Disabled If enabled (ON), a partial opening command given on the partial opening position is ignored. With contact 30-20 closed (for example with the timer or manual selector), the gate will open partially. If it is then fully opened (opening command) and reclosed (even with automatic closing), it will stop at the partial opening position.	ON OF
D6	D6 - Selection of the device connected to terminals 1-6 <ul style="list-style-type: none"> • NO - None • PH - Photocells • P41 - Photocells with safety test • SE - Safety edge (if the 1-6 contact opens, after stopping, a 10-cm disengagement is performed). • S41 - Safety edge with safety test (if the 1-6 contact opens, after stopping, a disengagement is performed with a duration depending on the selection RA → DE) 	NO PH P41 SE S41
SM	SM - Operating mode of terminals 1-6 <ul style="list-style-type: none"> • 00 - During movement, opening of the safety contact stops the motion (with disengagement if parameter D6 → SE / S41). • 01 - During movement, opening of the safety contact stops the motion (with disengagement if parameter D6 → SE / S41). Once the contact is closed again, the interrupted movement resumes. 	00 01 06

→ → → → → → → →



















<p>SM</p>	<ul style="list-style-type: none"> • 02 - During movement, opening of the safety contact stops the motion (with disengagement if parameter D6 → SE / S41). Once the contact is closed again, an opening cycle is performed. • 03 - During the closing cycle, opening of the safety contact reverses the movement. During the opening cycle, the safety device is ignored. • 04 - During the opening cycle, opening of the safety contact stops the movement (with disengagement if parameter D6 → SE / S41). When the contact closes again, the opening cycle resumes. During the closing cycle, the safety device is ignored. • 05 - During the closing cycle, opening of the safety contact stops and reverses the movement. During the opening cycle, opening of the safety contact stops the movement (with disengagement if parameter D6 → SE / S41). • 06 - During a movement, opening of the safety contact stops the motion. When the contact closes again, automatic closing is disabled. 	<p>00 <u>00</u></p> <p>01</p> <p>02</p> <p>03</p> <p>04</p> <p>05</p> <p>06</p>
<p>D8</p>	<p>D8 - Selection of the device connected to terminals 1-8</p> <ul style="list-style-type: none"> • NO - None • PH - Photocells • P41 - Photocells with safety test • SE - Safety edge (if the 1-8 contact opens, after stopping, a 10-cm disengagement is performed) • S41 - Safety edge with safety test (if the 1-8 contact opens, after stopping, a disengagement is performed with a duration depending on the selection RA → DE) 	<p>NO</p> <p>PH <u>PH</u></p> <p>P41</p> <p>S41 <u>S41</u></p> <p>SE</p>
<p>S0</p>	<p>S0 - Operating mode of terminal 1-8 when open</p> <ul style="list-style-type: none"> • ON - Enabled • OF - Disabled <p>If enabled (ON) when the automation is stopped (barrier closed or partially open), any movement is prevented.</p> <p>If enabled (OF) when the automation is stopped (barrier closed or partially open), an opening command is allowed.</p>	<p>ON <u>ON</u></p> <p>OF</p>
<p>68</p>	<p>68 - Selection of the device simultaneously connected to terminals 1-6 and 1-8</p> <ul style="list-style-type: none"> • NO - None • SE - Safety edge • S41 - Safety edge with safety test <p>If different from NO, the simultaneous opening of inputs 1-6 and 1-8 causes:</p> <ul style="list-style-type: none"> • movement stop and reversal during a closing operation. • stop and disengagement of a duration depending on the selection RA → DE during an opening operation. 	<p>NO <u>NO</u></p> <p>S41</p> <p>SE</p>
<p>LP</p>	<p>LP - Function of output +LP-</p> <ul style="list-style-type: none"> • 00 - courtesy light • 01 - electric lock (activated for a time defined by the parameter) • 02 - electric lock + release stroke (time defined by the parameter) • 03 - ON/OFF flashing without oscillator (active with motor in action) • 04 - ON/OFF flashing LED without oscillator (with motor in action) • 05 - ON for flashing LED with internal oscillator • 06 - Proportional indicator light for open gate (with battery operating signal) • 07 - Fixed indicator light for open gate (automation not closed) • 08 - Automation closed (activated with the gate completely closed) • 09 - Automation open (activated with gate completely open) • 10 - Automation in motion (also used for electromagnets powered for the entire operation) • 11 - Automation opening • 12 - Automation closing • 13 - Maintenance alarm • 14 - Batteries almost flat signal • 15 - LED strip (flashing during movement) • 16 - QIKAFE electromagnetic blocking • ON - Output always active 	<p>00</p> <p>01</p> <p>02</p> <p>03 <u>03</u></p> <p>04</p> <p>05</p> <p>06</p> <p>07</p> <p>08</p> <p>09</p> <p>10</p> <p>11</p> <p>12</p> <p>13</p> <p>14</p> <p>15</p> <p>16</p> <p>ON</p>



	<p>G3 - Relay G3 output function (C - NO)</p> <ul style="list-style-type: none"> • 00 - courtesy light • 04 - ON/OFF flashing LED without oscillator (with motor in action) • 05 - ON for flashing LED with internal oscillator • 06 - Proportional indicator light for open gate (with battery operating signal) • 07 - Fixed indicator light for open gate (automation not closed) • 08 - Automation closed (activated with the gate completely closed) • 09 - Automation open (activated with gate completely open) • 10 - Automation in motion (also used for electromagnets powered for the entire operation) • 11 - Automation opening • 12 - Automation closing • 13 - Maintenance alarm • 14 - Batteries almost flat signal • ON - Output always active 	
	<p>13 - Function of output 13</p> <ul style="list-style-type: none"> • 06 - Proportional indicator light for open gate (with battery operating signal) • 07 - Fixed indicator light for open gate (automation not closed) • 08 - Automation closed (activated with the gate completely closed) • 09 - Automation open (activated with gate completely open) • 10 - Automation in motion (also used for electromagnets powered for the entire operation) • 11 - Automation opening • 12 - Automation closing • 13 - Maintenance alarm • 14 - Batteries almost flat signal • ON - Output always active 	
	<p>LU - Setting switch-on time for the courtesy light</p> <p>The courtesy light can be driven through the LP/C - NO/13 outputs by setting the parameter IO → LP → 00 or IO → G3 → 00 or IO → 13 → 00. The adjustment is performed with different sensitivity intervals.</p> <ul style="list-style-type: none"> • NO - Disabled. The courtesy light does not switch on at the beginning of the maneuver. • from 01" to 59" with intervals of 1 second • from 1' to 2' with intervals of 10 seconds At each interval the display will show the following values: <ul style="list-style-type: none"> - 1'1 → 1 minute and 10 seconds... - 1'5 → 1 minute and 50 seconds • from 2' to 4' with intervals of 1 minute • ON - Permanently ON (switched OFF with remote control) <p> The courtesy light switches on at the beginning of each maneuver. To make it independent, set LU → NO</p>	
	<p>LG - Switch-on time for independently commanded courtesy light</p> <p>The courtesy light can be driven through the LP/C - NO/13 outputs by setting the parameter IO → LP → 00 or IO → G3 → 00 or IO → 13 → 00. The adjustment is performed with different sensitivity intervals.</p> <ul style="list-style-type: none"> • NO - Disabled. It is not possible to switch on the courtesy light with an independent control. • from 01" to 59" with intervals of 1 second • from 1' to 2' with intervals of 10 seconds At each interval the display will show the following values: <ul style="list-style-type: none"> - 1'1 → 1 minute and 10 seconds... - 1'5 → 1 minute and 50 seconds • from 2' to 4' with intervals of 1 minute • ON - Permanently ON (switched OFF with remote control) <p> The activation can be made independent (LU → NO) and controlled separately using the dedicated button on the remote control.</p>	













	BR – Courtesy Light / LED Strip Brightness Level Allows you to set the brightness level of the courtesy light or LED strip assigned to the LP output (IO → LP → 00 or IO → LP → 15). <ul style="list-style-type: none"> • LO - Low brightness • MI - Medium brightness • HI - High brightness 	
	LR - Electric lock release time [s] If enabled, this indicates the electric lock activation time at the start of every opening operation with the automation closed. <ul style="list-style-type: none"> • from 0.1 to 3.0 s with intervals of 0.1 s 	
	PV - Power supply via solar panels (for future use) <ul style="list-style-type: none"> • ON - Enabled • OF - Disabled 	
	ES - “Green Mode” [disconnection of accessories connected to terminals 0-1] ON - Enabled (the red dot to the right of the display flashes every 5 s). OF - Disabled Power supply disconnection mode is activated after 5 minutes with the gate closed, or when the gate is idle and automatic closure is not enabled. <div data-bbox="311 542 887 598" style="border: 1px solid blue; padding: 2px;">  The automation resumes its normal operation when a command is received on the radio board or after a terminal 30-5 / 30-20. </div> <div data-bbox="311 606 887 662" style="border: 1px solid yellow; padding: 2px;">  The installer, in the case of the installation of an accessory that requires power to always be on, can set the selection to OFF and deactivate the function. </div>	
	LB - Indication that batteries are almost flat <ul style="list-style-type: none"> • 00 - Visualisation on the display (alarm message 00) • 01 - Visualisation on flashing light (with the automation idle, 2 flashes are made and repeated every hour) and on display (alarm message 00) • 02 - Visualisation on “open barrier” indicator light (with automation closed, 2 flashes are made and repeated every hour) and on display (alarm message 00) 	
	LL - Voltage threshold for indicating that batteries are almost flat (V) 22 - Minimum 28 - Maximum <div data-bbox="311 893 887 949" style="border: 1px solid blue; padding: 2px;">  It is set with an interval of sensitivity of 0.5 V shown when the decimal point on the right lights up. </div>	
	B0 - Battery mode <ul style="list-style-type: none"> • 00 - Anti-panic (performs the opening operation following a mains supply failure. The automation opens but does not accept any other commands until the mains supply has been restored). • 01 - Continuous operation - the last operation performed before control panel switch-off with dead batteries will be an opening. • 02 - Continuous operation - the last operation performed before control panel switch-off with dead batteries will be a closure. 	



RO

RO - Radio operations and connectivity

The menu allows you to manage all the parameters of the radio/wireless functions of the control panel.

Parameter	Description	Available selections
EP	<p>EP - Encrypted message setup for remote-control transmission (AES-128-bit mode and Protected mode)</p> <p>If the option to receive encrypted messages is enabled, the control panel will be compatible with "ENCRYPTED" or "Protected" type transmitters.</p> <ul style="list-style-type: none"> • OF - Disabled • ON - Enabled. 	ON OF
SR	<p>SR - Remote controls memorization</p>  <p>By pressing , the indicator begins to flash SR and the desired buttons can be associated. After OK is displayed, the indicator continues to flash SR, allowing another button to be memorized. To exit, press  or  for 2 seconds to move to the next menu item.</p> <p> If the display shows a flashing SR, the remote control may already be memorized.</p>	
RM	<p>RM - Radio receiver operation</p> <p>This is the function associated with the radio command when only one channel is memorized (regardless of which one it is).</p> <ul style="list-style-type: none"> • 1-5 - Step-by-step • 1-3 - Opening 	1-5 1-3
TX	<p>TX - Visualisation of counter showing remote controls stored</p> 	
MU	<p>MU - Indication of maximum number of remote controls that can be stored in the integrated memory</p> <p>You can store a maximum of 100 or 200 remote control codes.</p>  <ul style="list-style-type: none"> • 20 - 200 remote controls that can be stored • 10 - 100 remote controls that can be stored <p> Selecting MU → 20 (200 remote controls), the configurations U1 and U2 saved with the command DF → SR will be lost. This also applies to the last configuration reloaded with RL. In addition, new configurations cannot be saved on U1 and U2.</p>	10 20
ER	<p>ER - Deletion of a single remote control</p> 	
EA	<p>EA - Total memory deletion</p>  <p>Requires double confirmation. Press  for 2 seconds, release and press for another 2 seconds.</p>	



	<p>C1, C2, C3, C4 - Selection of CH function of stored remote control</p> <ul style="list-style-type: none"> • NO - No setting selected • 1-3 - Opening command • 1-4 - Closing command • 1-5 - Step-by-step command • P3 - Partial opening command • LG - Courtesy light 	
	<p>If even just one (any) CH key of the remote control is stored, the opening or step-by-step command is implemented.</p>	
	<p> The 1-3 (opening) and 1-5 (step-by-step) options are available as alternatives, and depend on the selection RM.</p>	
	<p>If 2-4 CH keys of a single remote control are stored, the functions matched in the factory with the CH keys are as follows:</p> <ul style="list-style-type: none"> • CH1 = opening/step-by-step command • CH2 = partial opening command • CH3 = courtesy light on/off command • CH4 = STOP command 	
	<p>RE - Setting memory opening from remote control</p> <ul style="list-style-type: none"> • OF - Disabled • ON - Enabled. <p>When enabled the remote programming is activated. To store new remote controls without using the control panel, refer to the remote control instructions.</p>	
	<p>Make sure you do not accidentally memorise unwanted remote controls.</p>	
	<p>MS - Setting of backward compatibility with old remote control units</p> <ul style="list-style-type: none"> • OF - Compatible with GOL4 and new ZEN remote controls. • ON - Compatible with ZEN series remote controls. <p> It is recommended to use MS = ON if only ZEN series remote controls are used on the system.</p>	
	<p>RK - Menu navigation using remote control keyboard</p> <ul style="list-style-type: none"> • ON - Enabled • OF - Disabled <p>With the display turned off, quickly type in the sequence of keys 3 3 2 4 1 from the stored remote control that is to be used. Make sure all the CH keys are stored.</p> <p> During navigation with a remote control keyboard, ALL the stored remote controls are inactive.</p> <p>To aid vision and adjustment (avoiding the need to continuously press the remote control unit), press the key or once begin slowly scrolling through the parameters. Pressing the or key twice starts fast parameter scrolling. To stop the scrolling, press . To confirm your choice of parameter, press again. To test any new setting, switch off the display and issue an opening command using key 3. Navigation using a remote control keyboard is automatically disabled after 4 minutes of inactivity or by setting RK → OF.</p>	
	<p>FQ - Radio frequency selection</p> <p>The visible parameters depend on the inserted Remote Connectivity Board (RCB) [connector J9].</p> <ul style="list-style-type: none"> • NO - no RCB connected • 43 - Radio 433MHz (RCB50E or RCB100E connected) • 86 - Radio 868MHz (RCB50E or RCB100E connected) 	



	VL - Holiday mode lock/release The radio controls transmitted by the radio frequency devices (remote controls and digital radio keyboard) are deactivated. <ul style="list-style-type: none">• ON - Enable holiday mode. Blocks all remote controls (radio frequency devices)• OF - Disable holiday mode. Unlocks all the remote controls (radio frequency devices) <p> If enabled, the display shows each time a radio command is received.</p>	
	BT - Bluetooth® mode <ul style="list-style-type: none">• ON - Enabled• OF - Disabled	
	WF - Setting WiFi functionality (for future use) Used to activate or deactivate the WiFi functionality. <ul style="list-style-type: none">• ON - WiFi enabled• OF - WiFi disabled <p> Enabling WiFi will increase power consumption; in this case, keep in mind that compliance with the standby consumption limits is not guaranteed.</p>	
	WR - Request to restart the connected WiFi device (for future use) → 2" <p> The parameter is only present if a WiFi device is connected.</p>	

MA - Mobile App access management

Allows you to view, grant and reset access permissions for the Mobile App:

DITEC GATE CONNECT PRO (installer version App)

To view the type of operator access, briefly press Enter 



The type of operator access will be displayed:

00 – No access configured.

01 – Temporary access (duration: 1 hour)



The 1-hour duration restarts each time the power supply is removed and restored, in order to facilitate maintenance and configuration operations.

02 – PIN access (user, without physical confirmation on the operator)

03 – PIN access (user) + temporary access enabled by the user to allow installer access

If there is no permission (**MA** = **00**), when the App requests temporary access on the display, the message **MA** will flash, confirm the request by keeping  pressed until **OK** appears.



The **MA** value will become **01**. If necessary, press  to exit the menu.

To set up PIN access follow the instructions on the Mobile App:

MA

DITEC GATE CONNECT (user version App)

USER ACCESS

To set up permanent access, the user can configure a unique PIN in the Ditec App: **GATE CONNECT** by following the procedure provided within the App. Temporary access must still be active (**MA** = **01**).

If maintenance is required and the automation is configured **MA** = **02**, the user can authorize temporary access for the installer from the **DITEC GATE CONNECT** App. In this case, **MA** will switch to **03** (active PIN + temporary access for the installer).

Temporary installer access will remain active until the user revokes it in the **DITEC GATE CONNECT** App. After revoking temporary access, the parameter returns to **MA** = **02** and the automation will only be accessible using a PIN.

Important: To grant or revoke temporary access to the automation, the user must be connected to the automation via Bluetooth.

CHANGES AND RESET PERMISSIONS WITH MA=02/03

Press ENTER for 2 seconds; the display will flash. Release and press again for another 2 seconds. The value of **MA** will change to **00**.



The RESET procedure must be completed on every smartphone on which a PIN has been configured, and the Bluetooth device must be unpaired. The device will appear as 'AUTOMATION_NAME_XX:XX' (ex: AIR1000B_6B:B6), or 'Ditec_GAP', depending on the installed iOS version.



DF

Diagnostic functions

The menu allows you to manage all the other parameters used for the additional services (diagnostic counters, FW update, energy saving, etc.).

Parameter	Description	Available selections
SP	<p>SP - Setting the password</p> <p>[example] 2"</p> <p>i This can only be selected when the password is not set.</p> <p>Setting the password prevents unauthorised personnel from accessing selections and adjustments. You can delete the set password by selecting the sequence JR1= ON, JR1= OFF, JR1= ON.</p>	
CU	<p>CU - Displaying the control panel firmware version</p> <p>→ Release 1.1 [example]</p>	
UP	<p>UP - Firmware update</p> <p>Activates the card bootloader in order to update the firmware. Contact after-sales service for more information</p>	
AL	<p>AL - Alarm counter</p> <p>Used to view, in sequence, the counters of alarms that have been triggered at least one time (alarm code + number of events). With and you can scroll through all the counters and see all the alarms recorded.</p>	
AH	<p>AH - Cronologia allarmi</p> <p>With and you can scroll through the entire alarm log. Used to view, in sequence, alarms that have been triggered (up to a maximum of 20). The display shows the alarm number and code, alternated. The highest number corresponds to the most recent alarm and the lowest number (0) corresponds to the oldest alarm.</p>	
AR	<p>AR - Alarm reset</p> <p>Resets all the alarms in the memory (counters and log).</p> <p>2"</p> <p>i At the end of installation, you are advised to delete the alarms in order to facilitate future checks.</p>	
CV	<p>CV - Display of total operations counter</p> <p>→182 operations [example]</p>	
CP	<p>CP - Display of partial operations counter</p> <p>→716 operations [example]</p>	
ZP	<p>ZP - Reset of partial operations counter</p> <p>2"</p> <p>For correct functioning, you are advised to reset the partial operations counter:</p> <ul style="list-style-type: none"> • after maintenance work; • after setting the maintenance alarm interval. 	



	<p>CA - Setting the maintenance alarm (factory setting - alarm deactivated: 0.0 00. 00) You can set the required number of operations (regarding the partial operations counter) for signalling the maintenance alarm.</p> <p> When the set number of operations is reached, the alarm message appears on the display .</p>
	<p>OA - Selecting maintenance alarm display mode 00 - Visualisation on display (alarm message 01 - Visualisation on flashing light (with the automation idle, 4 flashes are made and then repeated every hour) and on display (alarm message).</p> <p> </p>
	<p>CH - Visualizzazione contatore ore di alimentazione</p> <p> → → → → → 215 hours (example)</p>
	<p>BH - Visualisation of counter for power supply hours via battery</p> <p> → → → → → 215 hours (example)</p>
	<p>SV - Saving user configuration on control panel storage module</p> <p> → → → → → </p> <p> If the display shows a flashing NO, it is possible that the memory module is not be installed.</p> <p> </p>
	<p>RC - Configuration loading</p> <p> → → → → → </p> <p>It is possible to load the user configurations previously stored U1 and U2 on the memory module of the control panel.</p> <p> </p>
	<p>RL - Loading of last configuration set</p> <p> → → </p> <p>The control panel automatically saves the last configuration set, and keeps it memorised in the storage module. In the event of a fault or the replacement of the control panel, the last configuration of the automation can be restored by inserting the storage module and loading the last configuration set.</p>
	<p>EU - Deletion of user configurations and last configuration set in the storage module</p> <p> → → → </p>
	<p>IM - Motor current display</p>
	<p>TB - Permanent display of the internal control panel temperature [°C] ON - Enabled OF - Disabled</p> <p> </p>
	<p>TT - Display of minimum and maximum temperatures recorded press for 2 seconds to reset the values minimum value with RH limit switch active</p>
	<p>TF - Limit switch test When the limit switches are configured and active, only FA/FC. If the limit switches are active but not configured: FA= NO (both limit switches active) FC= NO (no limit switch active)</p> <p> </p>



BL - Display of the battery voltage level

This parameter shows the battery voltage level:

- Lo** - Automation idle. The battery voltage level is low (< 22 V)
- 22** - Battery voltage level > 22 V and < 23 V
- 23** - Battery voltage level > 23 V and < 24 V
- 24** - Battery voltage level > 24 V and < 25 V
- 25** - Battery voltage level > 25 V and < 26 V
- 26** - Battery voltage level > 26 V and < 27 V
- 27** - Battery voltage level > 27 V and < 28 V
- 28** - Battery voltage level > 28 V



The parameter is only visible in the menu if the main power supply is missing and the battery kit is connected. In battery mode, without a network, the automation speed is reduced to a maximum of 15 cm/s.

EL - Automation efficiency level

- This value can be used to evaluate the mechanical quality of the gate and to understand if the chosen automation is adequate. In case of values below 90%, mechanical maintenance is recommended to restore efficiency or the adoption of automation with higher performance (e.g. motor with higher power).
- During normal use, this parameter indicates the efficiency of the automation, updating its state of degradation in real time:
 - **90%-99%** - High level of efficiency, automation in excellent condition.
 - **50%-89%** - Average efficiency level, performance starts to degrade.
 - **10%-49%** - Low level of efficiency, degraded performance and maintenance necessary.



RD - Resetting factory settings

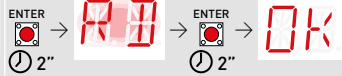

8. EXAMPLES OF INSTALLATION

8.1 PARALLEL WIRING DIAGRAM

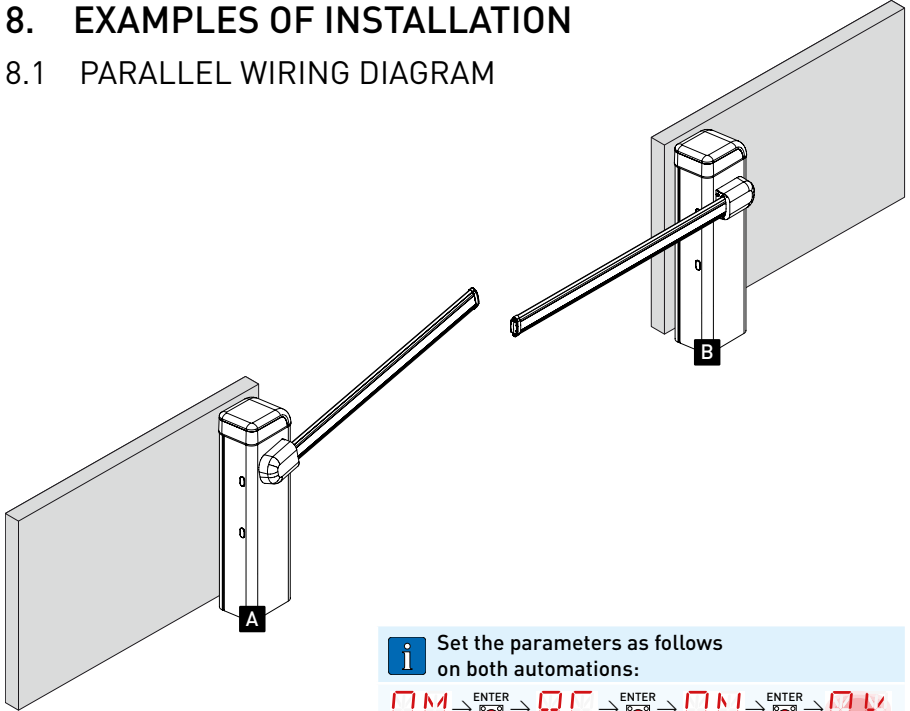

i Set the parameters as follows on both automations:

`OM` → ENTER → `AC` → ENTER → `ON` → ENTER → `OK`
`IO` → ENTER → `ES` → ENTER → `OF` → ENTER → `OK`
`IO` → ENTER → `TS` → ENTER → `1-3` → ENTER → `OK`
`RO` → ENTER → `VL` → ENTER → `ON` → ENTER → `OK`

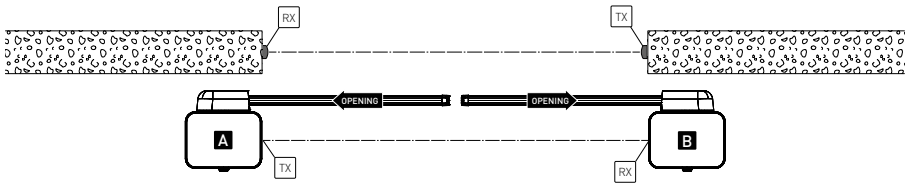

! Keep the RCB100E receiver installed on both barrier control units to maintain the Bluetooth functions, which are useful for maintenance and configuration via the app. Set parameter `VL = ON` to disable radio command reception and use only the BIXR2 receiver.

9. SIGNALS VISUALISED ON THE DISPLAY

9.1 DISPLAYING TEMPORARY SAFETY MESSAGES

• OM → DS → 01 / OM → DS → 03			
Display	Description	Display	Description
1-2	1-2 - Enable command automatic closing	68	68 - Device selection simultaneously connected at terminals 1-6 and 1-8
1-3	1-3 - Opening command	1-6	1-6 - Safety device with stop when opening and closing
1-4	1-4 - Closing command	S1	S1 - Detection of stop during closure
1-5	1-5 - Step-by-step command	1-8	1-8 - Safety with reversal during closure
P3	P3 - Partial opening command	1-9	1-9 - STOP command
4P	4P - Closing command with a person present	3P	3P - Opening command with Person present
RX	RX - Radio reception (of any memorised key of a transmitter stored in the memory)	S2	S2 - Detection of stop during opening
RV	RV - Rolling-code radio reception out of sequence	00	00 - Reaching the limit of obstacle detection during opening
NX	NX - Radio reception (from any non-memorised key)	0C	0C - Reaching limit of obstacle detection during closure
 With the selection: OM → DS → 01 it is also visualised when a command is received from a non-stored transmitter			
EX	EX - Radio reception rolling-code out of sequence	MQ	MQ - Operation for learning mechanical stops in progress
EP	EP - Radio reception not compliant with configuration of parameters RD → EP	HT	HT - Heating of the motors (NIO function) in progress
CX	CX - Receipt of command from AUX card	HS	HS - Sharp NIO start-up
J1	JR1 - Change in JR1 jumper status	FC	FC - Closure limit switch (only for BOX3BH)
VL	VL - Enable/disable holiday mode The radio controls transmitted by the radio frequency devices (remote controls and digital radio keyboard) are deactivated.	FA	FA - Opening limit switch (only for BOX3BH)
SW	SW - Release door open When the release door is closed, the control panel runs a RESET (alarm XX). The reset can be ignored by pressing  +  keys for 3 seconds until it stops flashing SW .	 If RESET is disabled, make sure not to move the barrier boom manually. If you re-enter the menu, the reset function is re-enabled.	

9.2 DISPLAY OF ALARMS AND FAULTS

Alarm type	Display	Description	Operation
Mechanical alarm	M0	M0 - Automation not configured	Check the configuration of the parameter P5
	M3	M3 - Automation blocked	Check the mechanical parts
	M4	M4 - Motor short circuit	Check connection of motor
	M8	M8 - Stroke too long	Check the rack / transmission chain
	M9	M9 - Stroke too short	Manually check that the gate moves freely
	MB	MB - Motor failure during an operation	Check connection of motor
	MD	MD - Irregular operation of the opening limit switch If the limit switch is configured but can't be found, from the deceleration start point OB each stop is seen as an obstacle and indicated with MD .	Check connection of the opening limit switch
	ME	ME - Irregular operation of the closing limit switch If the limit switch is configured but can't be found, each stop (from the deceleration start point CB) is seen as an obstacle and indicated with ME .	Check connection of the closing limit switch
	MI	MI - Detection of fifth consecutive obstacle	Check for the presence of permanent obstacles along the stroke of the automation
	ML	ML - Inverted limit switches	Check the positioning and connection of the limit switches. Also check connection of motor
	OD	OD - Obstacle during opening	Check for the presence of obstacles along the automation stroke
	OE	OE - Obstacle during closure	Check for the presence of obstacles along the automation stroke
	OF	OF - Automation blocked on opening	Check the mechanical parts and make sure there are no obstacles along the automation stroke.
	OG	OG - Automation blocked on closure	Check the mechanical parts and make sure there are no obstacles along the automation stroke.
	Alarm Settings	S6	S6 - Incorrect setting of safety device test

Internal control panel alarm		I5 - No voltage 0-1 (faulty voltage regulator or short-circuit on accessories)	Check there is no short circuit in connection 0-1. If the problem persists, replace the control panel.
		I6 - Excessive voltage 0-1 (faulty voltage regulator)	Replace the control panel
		I7 - Internal parameter outside limits error	Reset. If the problem persists, replace the control panel.
		I8 - Program sequence error	Reset. If the problem persists, replace the control panel.
		IA - Internal parameter error (EEPROM/FLASH)	Reset. If the problem persists, replace the control panel.
		IB - Internal parameter error (RAM)	Reset. If the problem persists, replace the control panel.
		IC - Operation time out error (>5 min or >7 min in acquisition mode)	Manually check that the barrier moves freely. If the problem persists, replace the control panel.
		IE - Power supply circuit fault	Reset. If the problem persists, replace the control panel.
		IM - Motor MOSFET alarm in short circuit or always ON	Check the settings / operating of any limit switches. Reset. If the problem persists, replace the control panel.
		IO - Interrupted motor power circuit (motor MOSFET open or always off)	Reset. If the problem persists, replace the control panel.
		IR - Motor relay error	Reset. If the problem persists, replace the control panel.
		IS - Error on motor current read circuit test	Reset. If the problem persists, replace the control panel.
		IU - Error on motor voltage read circuit test	Reset. If the problem persists, replace the control panel.
		TH - Intervention of high temperature safety device	Do not carry out any operations. If the problem persists, contact Technical Service
		VH - Automation blocked due to high temperature	Do not carry out any operations. If the problem persists, contact Technical Service
		XX - Firmware reset commanded by the simultaneous pressing +	
		WD - Firmware reset not commanded	
Power supply alarm		P0 - No mains voltage	Check that the control panel is powered correctly. Check the line fuse. Check the mains power supply.
		P1 - Microswitch voltage too low	Check that the control panel is powered correctly.

Radio operations alarm	R0	R0 - Insertion of a storage module containing a number of stored remote controls above 100 The setting is made automatically R0 → MU → 20	To save the system configurations on the storage module, delete any stored remote controls and bring the total to less than 100. Set R0 → MU → 10
	R3	R3 - Storage module not detected	Insert a storage module
	R4	R4 - Storage module not compatible with the control panel	Insert a compatible storage module
	R5	R5 - No serial communication with the storage module	Replace the storage module
	R6	R6 - Insertion of a specific storage module for testing	
	RV	RV - Insertion of slot-in radio cards	
Battery alarm	B0	B0 - Battery almost flat	Check battery voltage. Replace battery
Accessories alarm	A0	A0 - Test of safety sensor on contact 6 failed	Check that the device SOFA1-A2 is working properly If the supplementary SOF card is not inserted, check that the safety test is disabled
	A1	A1 - Test of safety sensor on simultaneous contacts 6 and 8 failed	Check the wiring and correct operation of the safety sensor
	A3	A3 - Test of safety sensor on contact 8 failed	Check that the device SOFA1-A2 is working properly If the supplementary SOF card is not inserted, check that the safety test is disabled
	A7	A7 - Incorrect connection of contact 9 to terminal 41	Check that terminal 1 and 9 are correctly connected
	A9	A9 - Overload on output +LP-	Check that the device connected to output +LP- is working properly



Alarms and faults can be displayed with any display selection.
The signalling of alarm messages takes priority over all other displays.

10. TROUBLESHOOTING

Problem	Possible cause	Signal Alarm	Operation
The control panel does not switch on	No power supply		Check the power supply cable and the relative wiring
The automation does not open or close	No power		Check the power supply cable
	Short circuited accessories	I5	Disconnect all the accessories from terminals 0-1 (a voltage of 24V  must be present) and then reconnect them one at a time. Contact Technical Service.
	Blown line fuse		Replace the fuse
	The safety contacts are open	I6 I8 68	Check that the safety contacts are closed correctly (NC)
	Safety contacts not correctly connected or self controlled safety edge not functioning correctly	A0 A1 A3 I6 I8 68	Check connections to terminals 6-8 on control panel and connections to the self-controlled safety edge
	The photocells are activated	I6 I8	Check that the photocells are Clean and working properly
	The automatic closure does not work		Issue any command. If the problem persists, contact Technical Service
	Motor fault	M3 M4	Check motor connection, if the problem persists, contact Technical Service
	Mechanical fault	M3 M8	Check the mechanical parts
	Release microswitch open	SW	Check that the door is closed correctly and the contact of the microswitch
	Control panel fault	I7 I8 IE IM IA IB IO IR	Contact Technical Service
Both limit switches are active	FA FC	Check the connection of the limit switches	

Problem	Possible cause	Signal Alarm	Operation
External safety devices not activating	Incorrect connections between photocells and control panel		<p>Check the display of I-6 / I-8. Connect the NC safety contacts together in series and remove any jumpers on the terminal board of the control panel</p> <p>Check the setting of IO → 06 and IO → 08.</p>
The automation opens / closes briefly and then stops	There is a presence of friction	MI MG IC	<p>Manually check that the automation moves freely and check the R1 / R2 adjustment. Contact Technical Service</p>
The remote control has limited range and does not work with the automation moving.	The radio transmission is impeded by metal structures and reinforced concrete walls		<p>Install the antenna outside</p> <p>Replace the batteries of the transmitters</p>
The remote control does not work	No storage module or incorrect storage module	R0 R5 R3	<p>Switch the automation off and plug in the correct storage module</p> <p>Check the correct memorisation of the transmitters on the built-in radio.</p> <p>If there is a fault with the radio receiver that is built into the control panel, the remote control codes can be read by removing the storage module.</p>
The flashing light is not working	The wires of the flashing light are detached or have short circuited	AG	<p>Check the connections. If the problem persists, contact Technical Service.</p>

11. CABINET CLOSURE

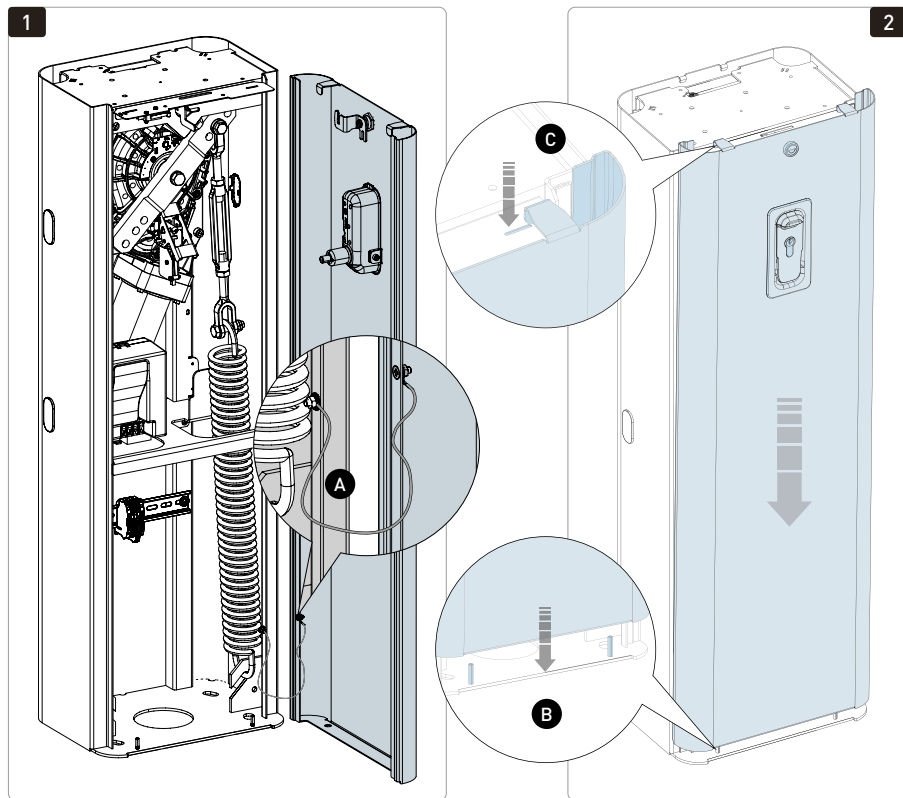

1. Fasten the grounding cable (supplied) **A** using the corresponding toothed washer and nut to the base of the cabinet and to the door.

2. Insert the door by tilting it and using the lower guides **B** as reference. Hook the door in position with reference to the upper slots **C**.

3. Insert the upper cover **D**. Insert the key **E** and turn it anticlockwise until it stops.

- Check that the cover is closed.



It is mandatory to close the door before performing any operation, even in manual mode. Handle the door carefully so as not to damage the electrical components.

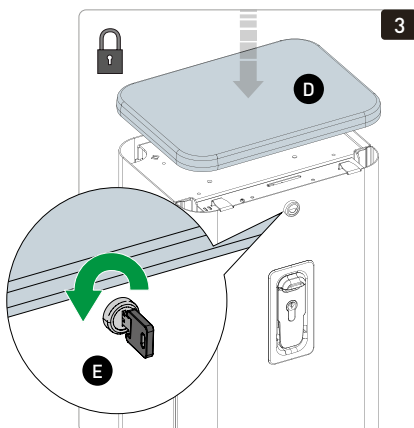

12. MANUAL RELEASE INSTRUCTIONS

In the event of: fault, power failure, ordinary or extraordinary maintenance, the procedure for manual release of the barrier is indicated below.

12.1 EXTERNAL MANUAL BARRIER RELEASE

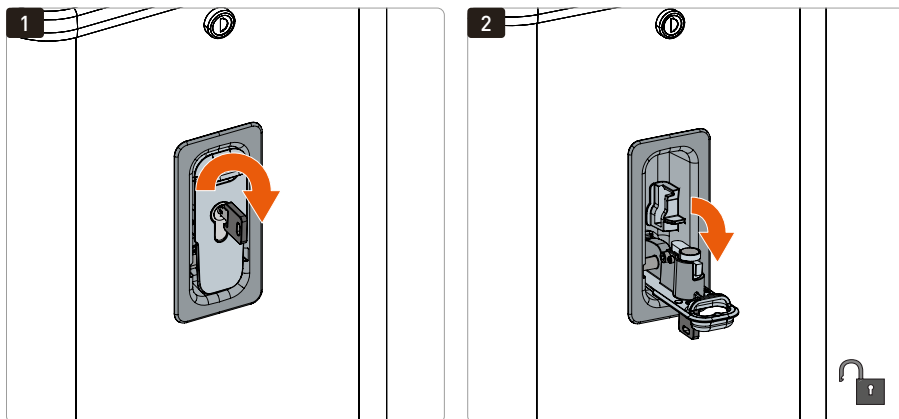

1. Insert the key and turn it anticlockwise until it stops.
2. Open the release door completely to perform the manual release of the automation.

12.2 RIPRISTINO DEL FUNZIONAMENTO AUTOMATICO

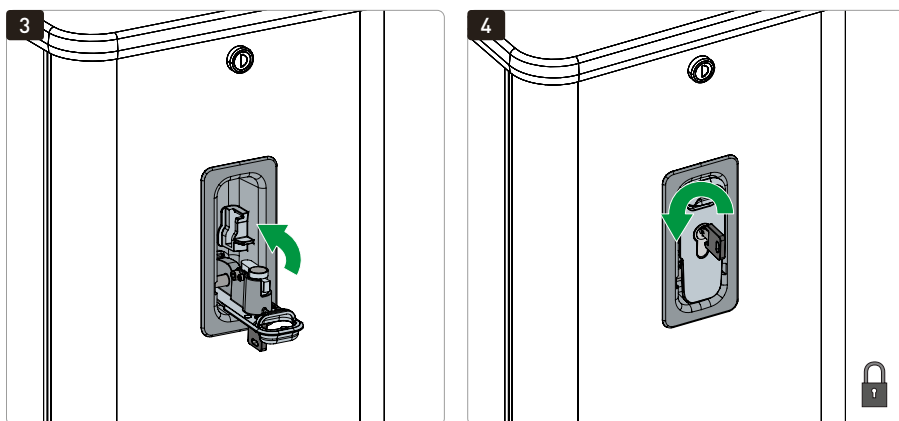

3. Close the door until it couples to perform the lock and restore the automatic operation of the automation.
4. Turn the key clockwise until it stops and then remove the key.



When the door is closed but the key is still horizontal, the release microswitch is open and all manoeuvres are prevented. To deactivate the barrier, the power supply must be removed and the batteries disconnected (if present).

In case of installation or extraordinary maintenance below is the procedure for internal manual unlocking of the barrier with open cabinet (this unlocking is indicated in cases where the European cylinder key of the external unlocking is not available).

12.3 INTERNAL MANUAL RELEASE OF THE BARRIER

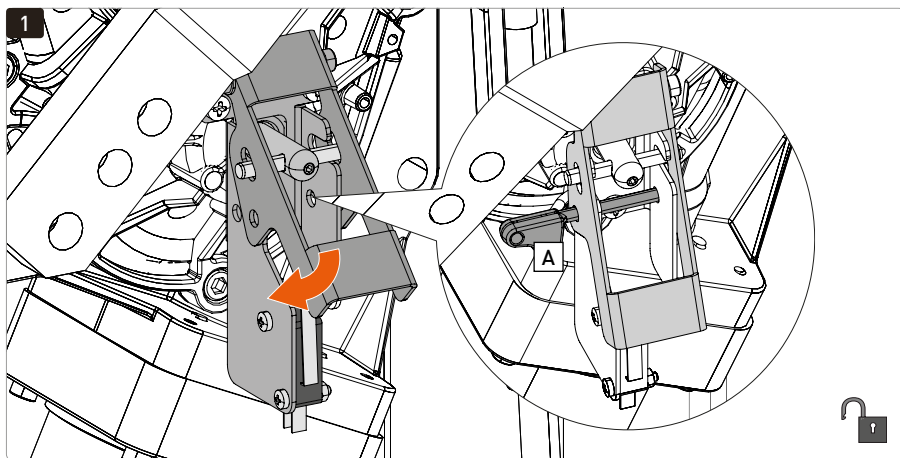

1. Push the lever to perform the manual release of the automation. It is advisable to use a pin (A) to be inserted in the holes indicated to keep the lever in position during operations.

12.4 RESET OF AUTOMATIC OPERATION

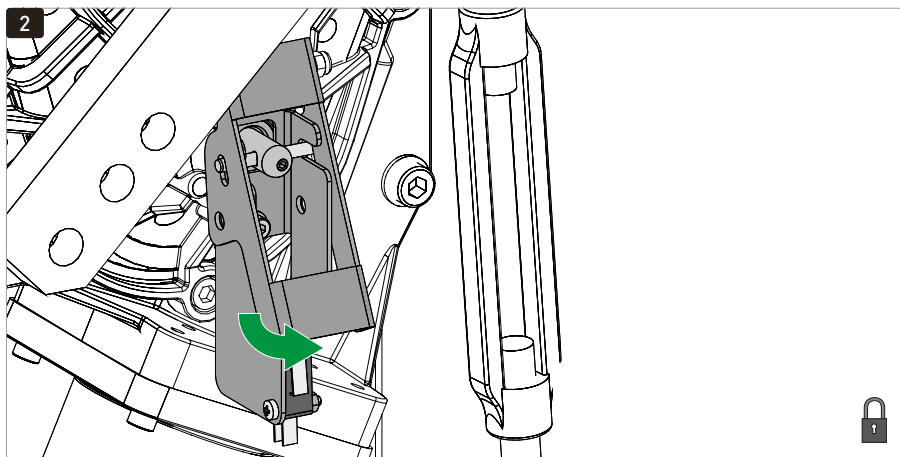

2. To perform locking and restore automatic operation of the automation: remove the pin (A) if inserted and pull the lever. Bring the rod to the use position and perform the sequeunte procedure to restore automatic operation of the automation.



Do not release with the springs tensioned without the arm. Perform arm locking and release with the motor switched off. When the barrier is released, the arm may move of its own accord.

13. ROUTINE MAINTENANCE PLAN

Perform the following operations and checks every 6 months, according to the intensity of use of the automation.

Disconnect the power supply and batteries (if present):

- Clean and oil the levers and check the nuts and screws are all well tightened.
- Clean and grease the articulated joint and spring tie rod as shown in the figure.
- Check the electrical connections.
- Check that the manual release functions correctly.
- Check that the arm is balanced correctly.
- Check the capacity value of the motor condenser.
- Check the state of wear of the mechanical parts, in particular the spring after about 500,000 work cycles.

Restore the power supply and reconnect the batteries (if present):

- Make sure the limit switches are working correctly.
- Check that the obstacle detection function is working correctly.
- Check that all control and safety functions are working correctly.

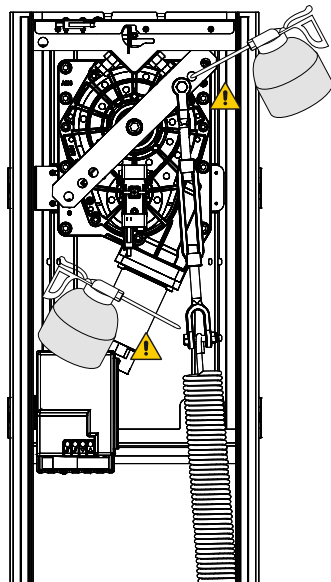

For spare parts, refer to the spare parts price list.

The Bluetooth® mark and logos are registered trademarks owned by Bluetooth SIG, Inc. and any use of such marks by ASSA ABLOY Entrance Systems AB is under license.

The Ditec brand is owned by ASSA ABLOY. All the rights relating to this material are the exclusive property of ASSA ABLOY Entrance Systems AB. Although the contents of this publication have been drawn up with the greatest care, ASSA ABLOY Entrance Systems AB cannot be held responsible for any damage caused by mistakes or omissions. We reserve the right to make changes without prior notice. Copying, scanning or changing the publication in any way is expressly forbidden without the prior written authorisation of ASSA ABLOY Entrance Systems AB.

 The crossed-out wheelee bin symbol indicates that the product should be disposed of separately from normal household waste. The product should be recycled in accordance with local environmental regulations for waste disposal. By separating a product marked with this symbol from household waste, you will help reduce the volume of waste sent to incinerators or land-fill and minimise any potential negative impact on human health and the environment.

