

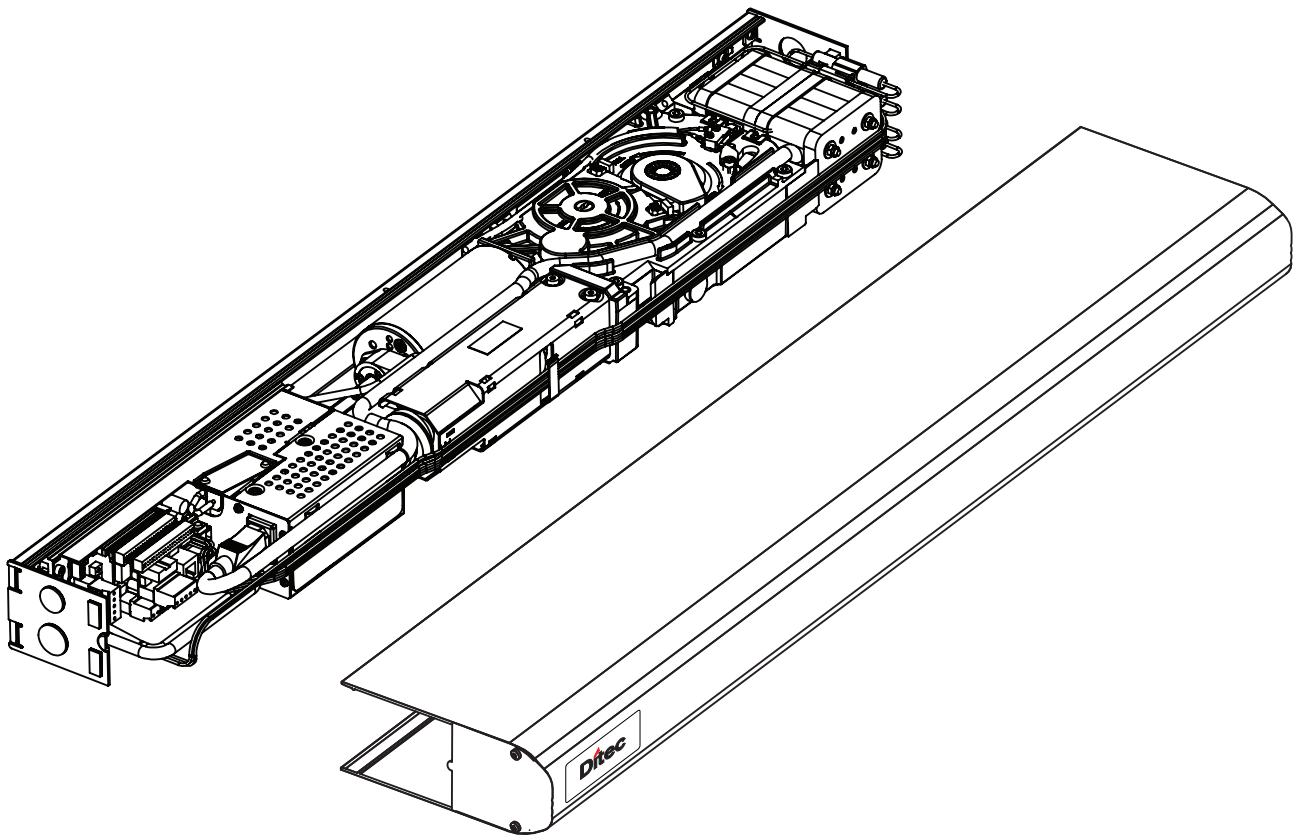

Swing Door Operator Ditec DAB305



Installation and Service Manual Original instructions

Original instructions

CONTENTS

1	Revision	7
2	Presentation of notes and warning signs	8
3	WARNING: Important safety instructions. Follow all instructions since incorrect installation can lead to severe injury.	9
4	Important information	12
4.1	Intended use	12
4.2	Safety precautions	12
4.3	Electronic equipment reception interference	12
4.4	Environmental requirements	13
5	Technical specifications	14
5.1	Permitted door weight and door width for Ditec DAB305	15
6	How the Ditec DAB305 works	16
6.1	Opening	17
6.2	Closing	17
6.3	Control switch	17
6.3.1	OFF/AUTO/OPEN switch	17
6.4	Functions on the basic control unit CUS7 (DAB305CU)	17
6.4.1	Power failure	17
6.4.2	Closing torque	18
6.4.3	Extended closing torque (CLTQ)	18
6.4.4	Power assist (POAS)	18
6.4.5	Push and go (PAG)	18
6.4.6	inverse (INV)Inverse (INV)	18
6.4.7	Activation delay (AD)	18
6.4.8	Overhead presence detector (OPD), frame mounted	18
6.4.9	Mat	19
6.4.10	Double acting	19
6.5	Functions on the extension unit DAB905ESE	19
6.5.1	KILL or FIRE function	19
6.5.2	Function of locks	19
6.5.3	Program selector (wall mounted)	20
6.5.4	Impulses	20
6.5.5	OPEN/CLOSE impulse	20
6.5.6	Power failure mode (backup batteries are installed) – optional	20
6.5.7	Nurse and bed functionality	21
6.6	Functions on the extension unit DAB905ESA	21
6.6.1	Presence impulse approach, door mounted	21
6.6.2	Presence detection swingpath, door mounted	22
6.6.3	Monitored safety sensors	22
6.6.4	FIRE input	22
6.6.5	Relay output	22
7	Models	23
7.1	Cover for single operator, surface mounted	23
7.2	Cover for double operator, surface mounted	24
8	Part identification	25
9	Arm systems	27
9.1	Pushing installation with PUSH-arm	27
9.2	Pulling installation with PULL-arm	28
9.3	20 mm extension	28
9.4	Pushing installation with PULL-arm	29
9.5	Double acting kits	31
9.6	Drive shaft extension kits	32
10	Options	33
10.1	Program selector	33
10.1.1	4-position switch COM400MHB/MKB (operates the electric lock)	33

10.2	Elbow switches	33
10.3	Sync cable for double doors (synchronizing of 2 operators)	33
10.4	Coordination unit	34
10.5	LED Cable	34
10.6	Battery backup unit	34
10.7	Cover piece kit	35
10.8	Closing time board kit	35
10.9	Fire kit	35
10.10	Labels	36
11	Pre-installation	37
11.1	General tips/Safety concerns	37
11.2	Operator/Door handing	38
11.3	Installation examples	38
11.4	Fastening requirements (but not included)	39
11.5	Tools required	40
12	Mechanical installation	41
12.1	PUSH arm system	44
12.2	PULL arm system	50
12.3	Operator with sliding PUSH arm system	56
12.4	INVERSE installation with PUSH arm system	57
12.5	INVERSE installation with PULL arm system	62
12.6	Installation of COORDINATOR UNIT on rebating double door and Fire Door installations	66
13	Electrical connection	74
13.1	Control units	75
13.1.1	CUS7 (DAB305CU)	75
13.1.2	Arm system selection	75
13.1.3	Extension units DAB905ESE / DAB905ESA	76
13.1.4	Extension unit DAB905ESE	77
13.1.5	Extension unit DAB905ESA	78
13.1.6	Installation on double doors	79
13.2	How to cut the jumper on the sync cable for double doors	79
13.3	Double door installations	80
13.4	Settings for double doors	80
13.5	Sensor cable inlet	81
13.6	Reset and indication device for Fire Doors	82
14	Start-up	84
14.1	Spring pre-tension	84
14.2	Micro switch	85
14.3	Adjusting the door stop	85
14.4	Auto-learn-automatically sets back and latch check (recommended)	87
14.4.1	Push the LEARN BUTTON (LRN)	88
14.4.2	Double doors	88
14.5	General adjustment	88
14.6	Connection of activation units and accessories	89
15	Cover	90
15.1	Fitting and removing the cover	90
15.2	Cover piece kit DAB05CMP1	90
16	Signage	91
17	Advanced settings	92
17.1	Learn with advanced setting of "back-check and latch-check"	92
17.2	Revert to default values for "back-check and latch-check" (Level 1)	92
17.3	Changing group of parameters (Level 2)	93
17.4	Classification (Level 3)	96
17.5	Overhead Presence Detection and Interlock (Level 4)	98
17.6	Enhanced Lock Kick, Fire Input and Extended Arm Selection (Level 5)	99
18	Guide for installation and adjustments	100
18.1	Complementary Safety Devices Swing Doors	100

18.2	Swing Doors Opening and Closing Time	100
18.2.1	How to find the correct opening and closing time	100
18.3	Diagrams for Door weight	101
18.3.1	Aluminum frame with glass	101
19	Troubleshooting	102
19.1	LED indication	103
20	Service/Maintenance	104

1 Revision

Following pages have been revised:

Page	Revision 7.0 → 8.0
76	Updated and added text.

2 Presentation of notes and warning signs

Various symbols and texts are used in this manual for easier understanding and identification.

Note! When you see **Note!** it contains useful advice and information to ensure correct and compliant usage of the system.



Potential hazardous situation that can lead to either minor or severe injuries or death and cause either minor or substantial property damage.



Potential hazardous situation that could lead to danger of electric shock and cause serious injury or death.

3 **WARNING: Important safety instructions. Follow all instructions since incorrect installation can lead to severe injury.**



- Failure to observe the information in this manual may result in personal injury or damage to equipment.
- To reduce the risk of injury to persons - use this operator with single or double pedestrian swinging or folding doors only.
- The mains power supply shall be installed with protection (fuse, circuit breaker) and an all-pole mains switch with isolating capability of Category III, shall be installed according to local regulations.
- Frequently examine the installation for imbalance where applicable and signs of wear or damage to cables, springs and mounting. Do not use if repair or adjustment is necessary.
- For indoor use only
- Make sure the ambient temperature is in the range specified on page [Technical specifications](#).
- Before installing the drive, check that the driven part is in good mechanical condition, correctly balanced and opens and closes properly.
- After installation, ensure that the mechanism is properly adjusted and that the protection system and any manual release function correctly.
- Do not use the equipment if repair or adjustment is necessary.
- **WARNING:** the drive shall be disconnected from its power source during cleaning, maintenance and when replacing parts.
- The operator can be used by children over 8 years of age if they have been instructed by a person in charge of their safety concerning use of the appliance in a safe way and understand the hazards involved.
- The operator can be used by children 8 years of age or younger if they are supervised by a person responsible for their safety.

- The operator can be used by persons with impaired physical, sensory or mental capacity if they have been instructed by a person in charge of their safety concerning use of the appliance in a safe way and understand the hazards involved.
- Cleaning and user maintenance shall not be made by children.
- Do not let children or anyone climb on or play with the door or the fixed/remote controls.
- Risk of battery explosion if wrong type of battery is used.
- The door has no safety during auto-learn cycle. Remain clear of swing path of door, as door may close rapidly.
- In all instances, where work is being done on the doorset, the area is to be secured from pedestrian traffic, and the power removed to prevent injury.
- In the event that the KILL circuit is activated, all Safety Functions of the door will be overridden causing the door to close even though an object or person may be in the door's path of travel, and therefore may be subject to injury. This mode of operation is most generally used to isolate an area in the event of a fire.
- The doorset can be operated automatically by sensors or manually by activators. It can also be used manually as a door closer.
- Do not dash through a closing door.
- This appliance may contain batteries that are only replaceable by skilled persons.
 - The battery must be removed from the appliance before it is scrapped
 - The appliance must be disconnected from the supply mains when removing the battery.
 - The battery is to be disposed of safely.
- Ensure that controls that can be set for a locked position are only activated when there are no other persons in the room.

- Ensure that entrapment between the driven part and the surrounding fixed parts due to the opening movement of the driven part is avoided. The following distances are considered sufficient according to EN 16005 to avoid entrapments for the parts of the body identified;
 - for fingers, a distance greater than 25 mm or less than 8 mm
 - for feet, a distance greater than 50 mm
 - for heads, a distance greater than 200 mm^a
 - and for the whole body, a distance greater than 500 mm
- ^a To comply with EN 60335-2-103:2015 a distance greater than 300 mm is needed
- Danger points shall be safeguarded up to a height of 2.5 m from the floor level.

4 Important information

4.1 Intended use

The Ditec DAB305 is an automatic swing door operator developed to facilitate entrances to buildings and within buildings through swing doors. The Ditec DAB305 is an electromechanical operator approved for fire door applications. It is to be installed indoors where it is suitable for almost all types of external and internal swing doors. This widely-used operator can be found in applications ranging from handicapped-access in private homes to high-traffic retail operations.

The motor and gear box are combined into a compact unit mounted alongside the control unit within the cover. The operator is connected to the door leaf with a range of different arm systems.

The door is designed to offer continuous use, a high degree of safety and maximum lifetime. The system is self-adjusting to the effects caused by normal variations in the weather conditions and to minor friction changes caused by e.g. dust and dirt.

For escape in emergency situations the doorset is opened manually, but can also be opened with motor under certain circumstances depending of required function.

This manual contains the necessary details and instructions for the installation, maintenance and service of the Swing Door Operator Ditec DAB305.

For use see User manual 1020517.

Save these instructions for future reference.

4.2 Safety precautions

Be sure to complete a risk assessment and site acceptance test before taking the door into operation.

To avoid bodily injury, material damage and malfunction of the product, the instructions contained in this manual must be strictly observed during installation, adjustment, repairs and service etc. Training is needed to carry out these tasks safely. Only Ditec-trained technicians should be allowed to carry out these operations.

4.3 Electronic equipment reception interference

The equipment may generate and use radio frequency energy and if not installed and used properly, it may cause interference to radio, television reception or other radio frequency type systems.

If other equipment does not fully comply with immunity requirements, interference may occur.

There is no guarantee that interference will not occur in a particular installation. If this equipment does cause interference to radio or television reception, which can be determined by turning the equipment off and on, the user is encouraged to try to correct the interference by one or more of the following measures:

- Re-orient the receiving antenna.
- Relocate the receiver with respect to the equipment.
- Move the receiver away from the equipment.
- Plug the receiver into a different outlet so that equipment and receiver are on different branch circuits.
- Check that protective earth (PE) is connected.

If necessary, the user should consult the dealer or an experienced electronics technician for additional suggestions.

4.4 Environmental requirements

Ditec products are equipped with electronics and may also be equipped with batteries containing materials which are hazardous to the environment. Disconnect power before removing electronics and battery and make sure it is disposed of properly according to local regulations (how and where) as was done with the packaging material.

5 Technical specifications

Ensure that the door operator with the technical specifications below is suitable for the installation.

Manufacturer:	ASSA ABLOY Entrance Systems AB
Address:	Lodjursgatan 10, SE-261 44 Landskrona, Sweden
Type:	Ditec DAB305
Mains supply:	100 to 240 V AC +10/-15%, 50/60 Hz, mains fuse max. 10 A (building installation) Note! The mains supply shall be installed with protection and an all-pole mains switch with isolating capability of Category III, at least 3 mm between contacts, shall be installed according to local regulations. These articles are not provided with the door.
Power consumption:	Max. 300 W
Auxiliary voltage:	24 V DC, max. 700 mA (max. 1000 mA including lock)
Mains fuse F1, F2:	2 x T 6.3 AH/250 V
Door size: Refer to EN 1154	PUSH arm system: size 4 - 7 PULL arm system: size 4 - 6
Max. Inertia J:	For PUSH = 140 kgm ² For PULL = 80 kgm ² Inertia = Door weight x (Door width) ² / 3
Electro-mechanical locking device:	Selectable: 12 V DC, max. 1200 mA or 24 V DC, max. 600 mA
Door opening angle:	PUSH arm: 80° - 110° with reveal 0 - 367 mm PULL arm and Sliding PUSH arm: 80° - 110° with reveal -20 to 130 mm
Opening time (0° - 80°):	Variable between 2.5 - 12 s
Closing time (90° - 10°):	Variable between 4 - 12 s
HOLD open time:	1.5 - 30 s
Ambient temperature:	-20 °C to +45 °C
Relative humidity:	Max. 95%
Drive unit weight:	7.6 kg
Class of protection:	IP20
Approvals:	Third party approvals from established certification organizations valid for safety in use, see Declaration of Incorporation.
Complies with: EN 16005, EN 60335-2-103, EN 1634-1	

This product is to be installed internally.

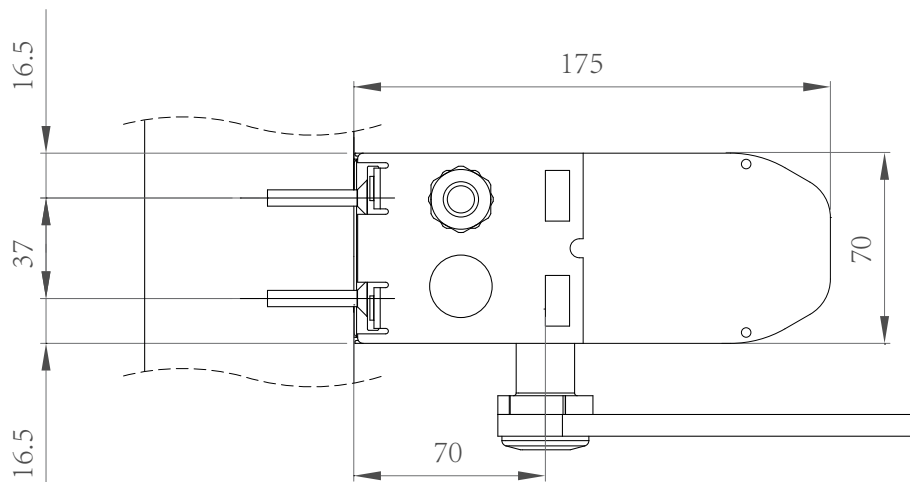

5.1 Permitted door weight and door width for Ditec DAB305

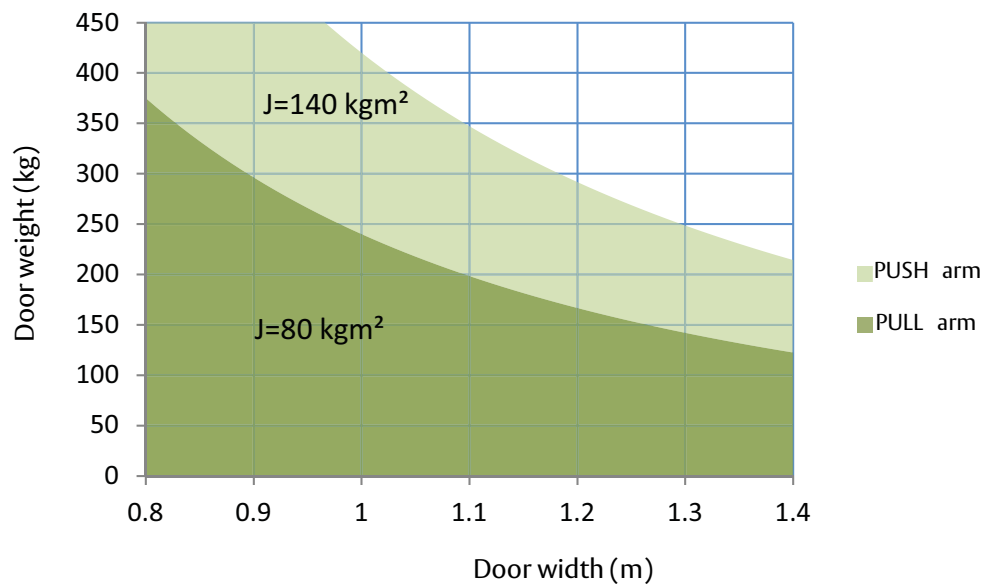

6 How the Ditec DAB305 works

The swing door operator Ditec DAB305 uses a DC motor which is connected to the output shaft by a combination of a worm gear and spur gears. The push- or pull arm system that is connected to the output shaft opens the door in a surface mounted application.

There is an adjustable spring mechanism, consisting of a helical compression spring combined with a linkage system including a pressure roller that acts on a cam curve that is attached to the output shaft. During opening of the door, the compression spring is tensioned by the rotation of the output shaft. During the closing cycle, the accumulated spring force is transferred to the output shaft by means of the cam curve and the pressure roller. The transferred spring force is acting in the closing direction.

The spring force can be adjusted so that there is appropriate force to close the door when it is manually operated or if there is a power failure.

It is possible to increase the closing force by using the motor in combination with the spring and thereby increase the door closing force (powered close).

The mechanism consist of:

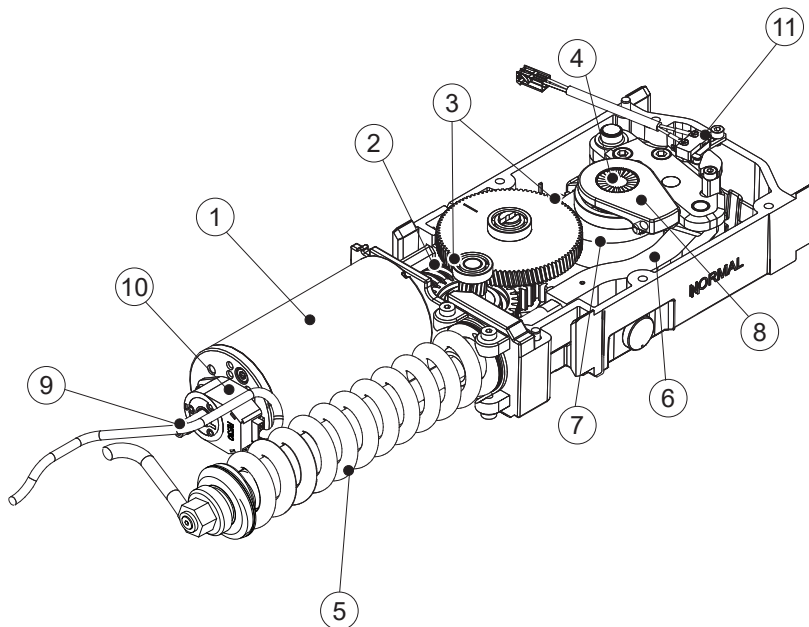

- 1 Motor
- 2 Worm gear
- 3 Two spur gears
- 4 Output shaft
- 5 Helical compression spring
- 6 Spring mechanism that transfer the spring force to the output shaft
- 7 Cam to optimise the torque on the output shaft
- 8 Mechanical door stop on the output shaft (adjustable)
- 9 Shaft for a mechanical coordinator
- 10 Encoder
- 11 Micro switch

6.1 Opening

When an activation signal is received by the control unit, the door is opened at the installer-adjusted opening speed. Before the door is fully open at back check, it slows automatically to low speed. The motor stops when the selected door opening angle has been reached. The open position is held by the motor.

If the door is obstructed while opening, it will either stall or stop which can be selected with a DIP-switch (SOS). Stop on stall is always active in OFF mode.

- Continue on stall - the door will continue to try to open during the hold open time.
- Stop on stall - the door will, even if hold open time has not expired, close after 2 seconds.

6.2 Closing

When the hold open time has elapsed, the operator will close the door automatically, using spring force and motor. The door will slow to low speed at latch check before it reaches the fully closed position. The door is kept closed by spring power or combined with extended closing torque by the motor.

6.3 Control switch

6.3.1 OFF/AUTO/OPEN switch

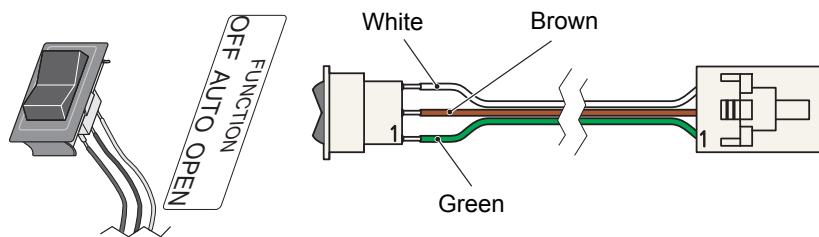

Function	Program
OFF	Key is the only valid impulse.
AUTO	Every impulses are valid.
OPEN	The door is held permanently open.

Note! If the door is often kept open by a wedge or magnet then select program selection OPEN or OFF, if not the operator will try to close the door, and this might damage the operator long-term.

6.4 Functions on the basic control unit CUS7 (DAB305CU)

[See page 75](#) for more information.

6.4.1 Power failure

During power failure the operator acts as a door closer with controlled closing speed and a micro switch will make a lock kick to secure latching (only fire rated version and no Inverse installation).

6.4.2 Closing torque

To comply with authority requirements or to overcome over/under pressure the closing torque can be adjusted according to EN 1154.

6.4.3 Extended closing torque (CLTQ)

If the potentiometer CLTQ is set to 0°, the door will close with normal spring power. If the potentiometer is turned clockwise, the motor will increase the closing torque. Extended closing torque will be reduced to zero:

- If the door mounted sensor is activated in closed position or during closing (even if manually opened). Applies not to program select OFF.
Also, Extended closing torque will be canceled after the first closing by KILL, in all program selections (except secondary door with older firmware).

6.4.4 Power assist (POAS)

The brake is very effective when the potentiometer POAS is set to 0°, and the door doesn't get any power assist. When you turn the potentiometer clockwise, the motor provides or increases power assist as you manually open the door.

It's important to know that the range of the POAS depends on the spring tension.

With active power assist, the door moves freely until it reaches a 45-degree angle, and only then does the brake activate, but with limited effect.

This means that if you open the door in a location where the wind might catch it, the door could gain significant speed before braking which could result in the door slamming into the stop arm, potentially breaking the arm adapter.

The installer should be aware of this risk and understand it before using the function.

6.4.5 Push and go (PAG)

DIP-switch to select Push and Go, ON or OFF. Push and Go is available from any door position. Push and Go is not active in program selector setting OFF.

6.4.6 inverse (INV)Inverse (INV)

DIP-switch to select when inverse installation.

To be used for doors in emergency escape routes where the door has to open in case of fire alarm (smoke evacuation). The door is opened by spring force and closed by motor operation. If lock is used, the lock must fulfill the ELtVTR-standard.

6.4.7 Activation delay (AD)

This function requires a constant inner impulse for the specified time before the door will open. Fixed 2 sec.

During closing the door will reopen immediately if impulsed.

6.4.8 Overhead presence detector (OPD), frame mounted

When an OPD sensor is mounted on the frame or operator cover just above the swing side of the door, it will—when activated—either keep the door open or closed. The sensor input is not sensitive during opening and closing. Lock-out signal is available as it is required by some OPD sensors for proper function.

- a closed door will not open, if the OPD detects activity in the field
- an open door will not close, if the OPD detects activity in the field
- during opening, the door will continue to open, even if the OPD detects activity in the field
- during closing, the door will continue to close, even if the OPD detects activity in the field
- the OPD is not active in program mode OFF, manually opened door or during battery operation (Power Save Mode).

6.4.9 Mat

Mat safety means that:

- a closed door will not open, if someone steps on the mat
- an open door will not close, if someone steps on the mat
- during opening, the door will continue to open, even if someone steps on the mat
- during closing, the door will continue to close, even if someone steps on the mat
- opening impulses are prevented during closing, if someone steps on the mat
- the mat is not active in program mode OFF, manually opened door or during battery operation (Power Save Mode).

6.4.10 Double acting

Opening inwards and with panic break out outwards

6.5 Functions on the extension unit DAB905ESE

Also see [page 77](#) for more information.

6.5.1 KILL or FIRE function



In the event that the KILL or FIRE circuit is activated, all Safety Functions of the door will be overridden causing the door to close even though an object or person may be in the door's path of travel, and therefore may be subject to injury. This mode of operation is most generally used to isolate an area in the event of a fire. In double doors, coordinator shall be used to ensure correct closing.

- During KILL the control will ignore all signals and close door(s) at normal speed or 5 seconds. In case of INVERSE installation, the control will ignore all signals and open door(s) at normal speed or 5 seconds (see [page 88](#)).
- If impulse controlled KILL or FIRE: The operator will resume normal operation after a KILL RESET. When manual RESET, jumper must be removed and reset button connected to terminal No. 8 and Ground.
- Or if state controlled KILL When KILL signal is no longer active, operator will resume normal operation.
- The behavior of the lock during KILL depends on the group of parameters. See [page 93](#).
- Green LED indicates trouble-free operation of the operator. No triggering of the connected devices (smoke detector or manual release button).
- Red LED indicates the release of one or more triggering devices (smoke detector or manual release button). This display is rated as kill or fire mode.

6.5.2 Function of locks

- The lock output is short circuit proof and can source a lock with 24 V DC, max. 600 mA. Lock function is active in programme selection EXIT and OFF
- The control has an available output of DC for external locks
- DIP-switches to select 12 or 24 V DC, locked with or without power
- DIP-switch for lock release and potentiometer for opening delay
- DIP-switch for lock kick to overcome binding in the locking device during closing (inactivated for Inverse door).
- Input to unlock signal from lock. Potentiometer for opening delay is to be set to max. As soon as unlock signal is received the door will start to open. The lock output signal shall be active low.

- If the door cannot fully close, the operator will perform a lock retry (once if manually, twice if automatically open).

6.5.3 Program selector (wall mounted)

- Input for OPEN, EXIT and OFF (if no program selector, AUTO is default).

Note! In OFF-position the operator will comply with the Low Energy Regulation and the door mounted sensors will be disregarded.

6.5.4 Impulses

- Input for OUTER impulse, KEY impulse and OPEN/CLOSE impulse.
Door will close after adjusted time on HOT / KHOT potentiometer.

6.5.5 OPEN/CLOSE impulse

The impulse will open the door and the door will stay open until a new impulse is given. If no impulse is given the door will close after 15 minutes. This can be made infinite by changing group of parameters, see page [93](#).

OPEN/CLOSE impulse works only in program selection AUTO. Can be programmed for OFF and EXIT as well.

6.5.6 Power failure mode (backup batteries are installed) – optional

- In case of power failure, normal operation can be carried out with impulses from the KEY SWITCH.
- Two contacts are available for connection of 2 x 12 V batteries (NiMH).
- DIP-switch for monitoring of batteries is also available. Faulty battery will be indicated by the LED on the DAB305CU. If selected the relay on DAB905ESA can give a contact information. The Battery Monitoring always has to be reset, when the batteries have been replaced. It is done by pressing the Learn button, while battery mode is active (mains disconnected).

Note! If battery mode is POWER SAVE, the reset has to be made during the door is opened by Key impulse.

- During POWER FAILURE the operator will finish the actual operating cycle and then switch of the battery supply. The battery powered operator can be reactivated to achieve a new operating cycle by an impulse on the KEY input.
- The operating mode during battery power can be changed from POWER SAVE to CONVENIENCE, see page [93](#). During CONVENIENCE MODE the operator will work as normal until the batteries are discharged. The batteries are rechargeable and will be charged by the control unit in the operator. New, fully charged batteries can typically open and close a door max. 300 times in convenience mode. In power save mode the operator can stand-by in up to 1 week, waiting for KEY impulse.

The following sensors are not active during battery operation POWER SAVE mode.

- Mat
- Overhead presence detector (OPD/OPS), frame mounted
- Presence impulse approach, door mounted
- Presence detection swingpath, door mounted

Note! All sensors works normally in CONVENIENCE MODE.

6.5.7 Nurse and bed functionality

Solution 1

Connect a jumper between 3 and 7 on the secondary DAB905ESE.

Use any impulse on primary to open primary door.

Use Open/Close impulse on secondary to open both doors.

Solution 2

Connect a jumper between 3 and 7 on the secondary DAB905ESE.

Set dip switch PAG on primary board to ON.

Use any impulse on primary to open primary door.

Push secondary door manually and it will open up automatically and stay open until primary door is closing.

Active in OFF, EXIT, AUTO and OPEN modes.

Solution 3

Connect a 1/0 switch between 3 and 7 on the secondary DAB905ESE.

Switch in pos. 1, impulses on primary will open only primary door.

Switch in pos. 0, impulses on primary will open both doors.

Solution 4

Connect a jumper between 3 and 7 on secondary DAB905ESE.

Set dip switch PAG on secondary board to On.

Any impulse on the primary control unit:

- Shorter than 2s opens only primary door.

- Longer than 2s opens both doors.

Note! How to connect KILL input is determined by chosen parameter group at the secondary, be sure that chosen group has KILL-impulse configuration Normally Open. If KILL has to be Normally Closed, terminal 3 and 7 should be disconnected instead of connected.

6.6 Functions on the extension unit DAB905ESA

[Also see page 78](#) for more information.

6.6.1 Presence impulse approach, door mounted

The presence impulse is active during fully open and closing. The sensor is mounted to the approach side of the door. Once the door is closed, the sensor is ignored and will not be active until the next impulse is received.

Note! When installed as a pair of doors, the presence impulse signal will re-open both doors. The sensor is not active in OFF mode, or during battery operation (Power Failure mode). For manually opened door, the PIMP sensor will be active when the advanced settings level 3 to classification 3-6.

6.6.2 Presence detection swingpath, door mounted

When a sensor that is mounted on the swing side of a door detects an object, it will send a command to the control unit to stall the door. If the control unit has received a short signal from the sensor and there is still hold open time left on the control unit, the door will continue on its way open if the object has cleared.

The inhibit/blanking potentiometer can be adjusted so that the sensor will avoid detecting a wall or object near the full open position. Presence detection has a higher priority than presence impulse.

Note! When installed as a pair of doors the presence detection signal will stop both doors, except for double egress doors. The behavior for double egress doors can be changed ([see page 93](#)). The sensor is not active in OFF mode or manually opened door. In this OFF mode the operator fulfills the Low Energy Standards.

6.6.3 Monitored safety sensors

Both presence impulse and presence detection can be monitored. If a sensor becomes defective, the operator will not accept any impulses if the presence detection sensor is defective. The door remains in closed position and can be used as a manual door.

If the presence impulse sensor is defective, the door will remain in open position. Switching the program selector to OFF will set the door control to low energy mode. Key impulse can be used as impulse.

6.6.4 FIRE input

Ground and 24 VDC are used for supply of smoke detectors, see [page 83](#).

Connection of fire alarm 12, 24 or 48 VDC is possible to connect to the FIRE input, see [page 89](#) and [99](#).

6.6.5 Relay output

A potential free contact COM/NO/NC used in the below four different way, where the first three are chosen by Parameter group (see 'Relay' in table at [page 93](#)). When indicating Error or KILL, the error relay is resting (connection COM-NC), and when indicating Door open or closed it is activated (connection COM-NO).

- Error indication
For external error indication, see [page 103](#).
- KILL output
Used to distribute KILL-signal to other door sets.
- Lock output
Used to control locks with other voltage than 12/24 VDC.
- Door indication (HW-wired with jumper)
Used for indicate an open or closed position of the door. The indication position is set by adjusting the inhibit/blanking potentiometer. For indication of closed door, adjust the Blanking potentiometer to minimum. For indication of open door, open the door by program select OPEN or any open-impulse, and adjust the Blanking potentiometer so that the Blanking LED is lit only in open position (or above desired position, just like blanking).

7 Models

The Ditec DAB305 is available as single doors model:

The operator is non-handed and not dependent on the hinges. The operator suits both pushing and pulling arm systems.

7.1 Cover for single operator, surface mounted

The product is delivered complete with back plate, control unit, end plates and cover. Total cover length CL includes end plates.

Pushing arm system shown.

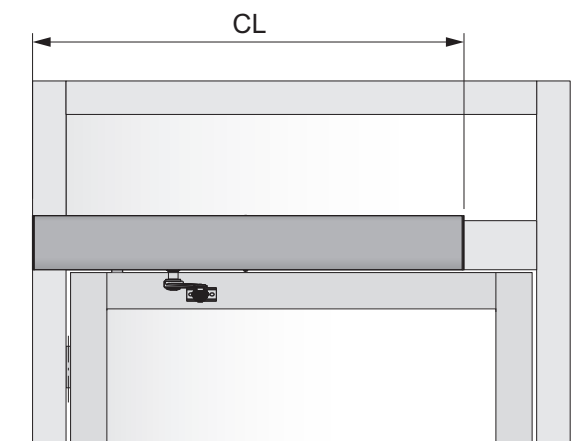

Standard cover.

CL = 840

7.2 Cover for double operator, surface mounted

Two operators can be mounted under the same cover (full length or a modular) to open one door each. Pushing and pulling arm system shown (double egress).

It is also possible to use two pushing or two pulling arm systems.

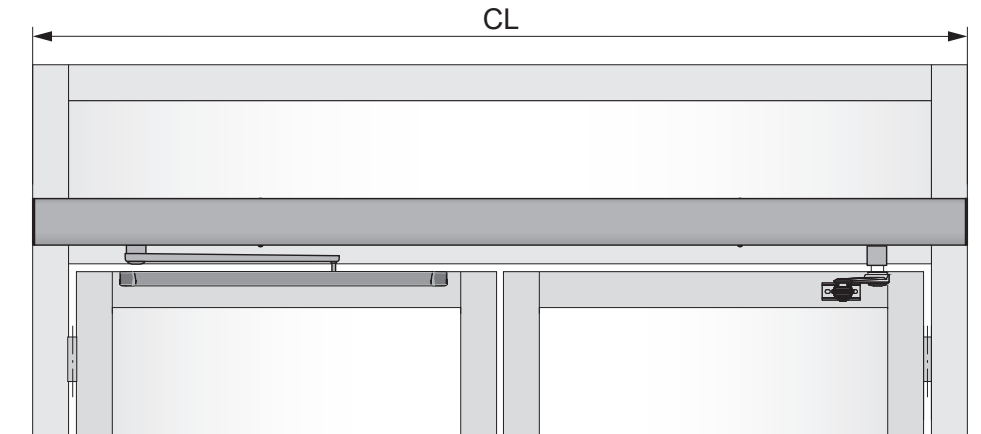

Full length cover.
Not available from
Ditec, to be arranged
locally.

$CL_{min.} = 1684$

$CL_{max.} = 3284$

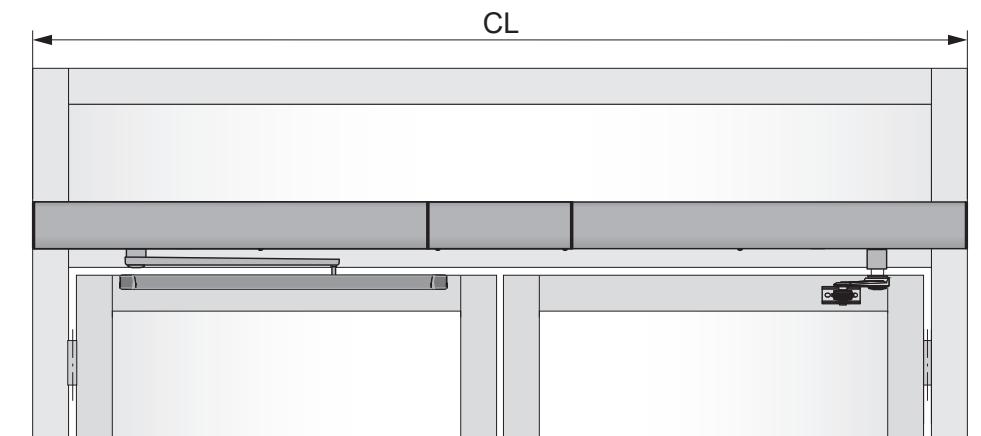

Modular cover using
cover piece between
two standard covers.

$CL_{min.} = 1714$

$CL_{max.} = 3284$

8 Part identification

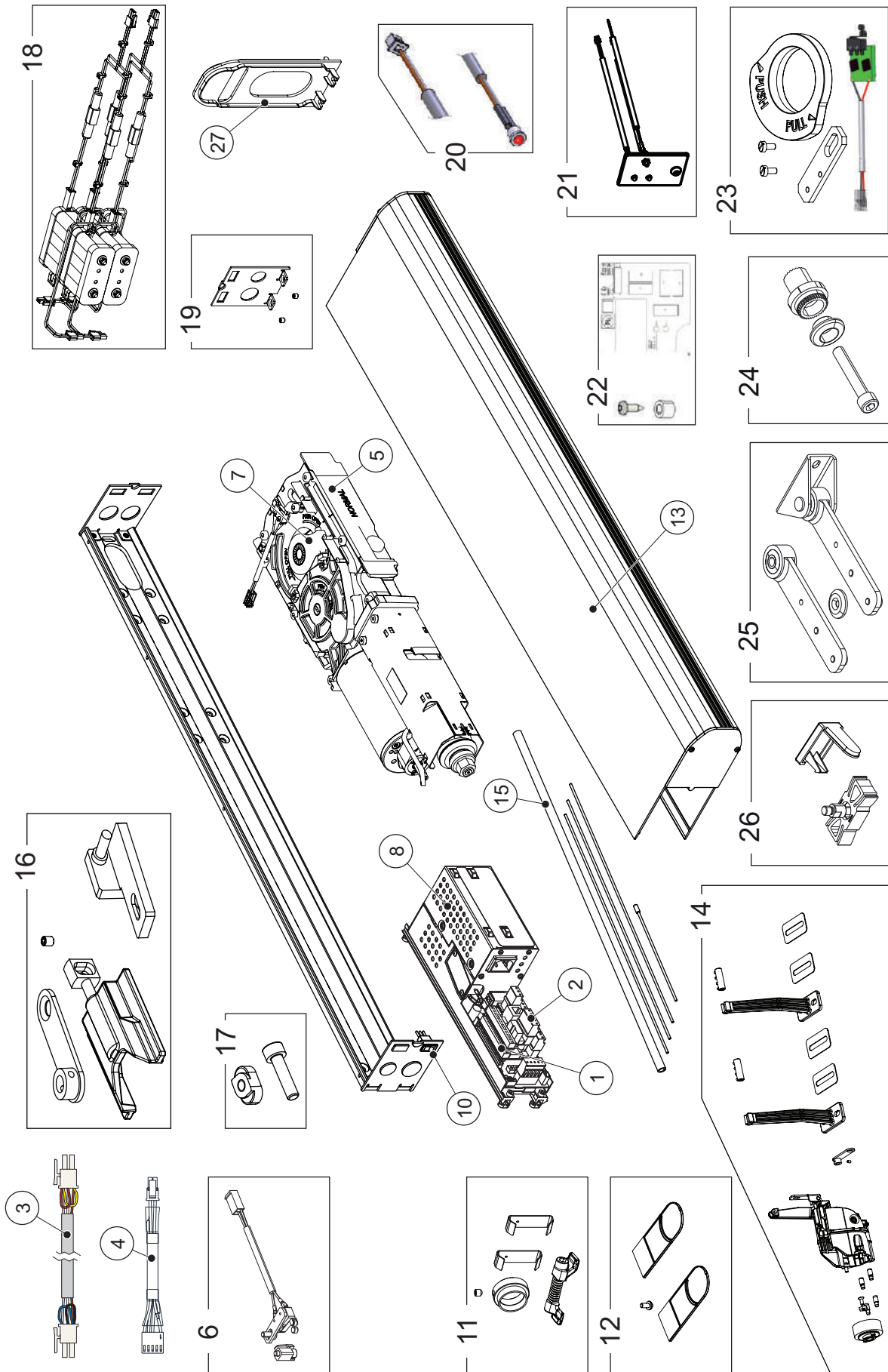

Item No.	Art. No.	Description
1	DAB905ESE	Kit for Security & Impulse
2	DAB905ESA	Kit for Safety
3	DAB905SYN	Sync cable double doors (L=3000 mm)
4	6DAB205EC	Encoder cable
5	6DAB305TUF	Transmission unit kit PUSH/PULL
6	6DAB305MSW	Micro switch kit
7	6DAB305SAK	Stop arm kit
8	6DAB305CU	Control unit without DAB905ESA/ESE boards
10	6DAB305OHS	OFF/AUTO/OPEN switch kit
11	6DAB305FTU	Fixing kit FB
12	6DAB305FC	Fill cover
13	6DAB305C	Cover
14	DAB805COU	Coordinator top assembly kit
15	DAB805ROD	Rod kit
16	6DAB305CS	Coordinator service kit
17	6DAB305FCU	Fixing for control unit
18	DAB905BAT3	Battery assembly
19	6DAB305BEP	Bottom end plate
20	DAB905LED	LED cable
21	DAB905RSD	Reset & Indication device
22	DAB305CBK	Closing brake kit
23	6DAB305SWC	Micro switch board & cam
24	6DAB305A	Adaptor kit
25	6DAB305PSSK	PUSH arm service kit
26	6DAB305PLSK	PULL arm service kit
27	6DAB305MC	Middle cap (2 pcs)

9 Arm systems

The installation process of arm systems is the same for Fire door installations, Basic installations and INVERSE installations.

9.1 Pushing installation with PUSH-arm

This arm system is delivered with drive arm, telescopic part and door fitting. It is used if the operator is installed on the wall on the opposite side of the door swing, and approved for fire door application for A up to 300 mm.

Art. No.: DAB805PSA3

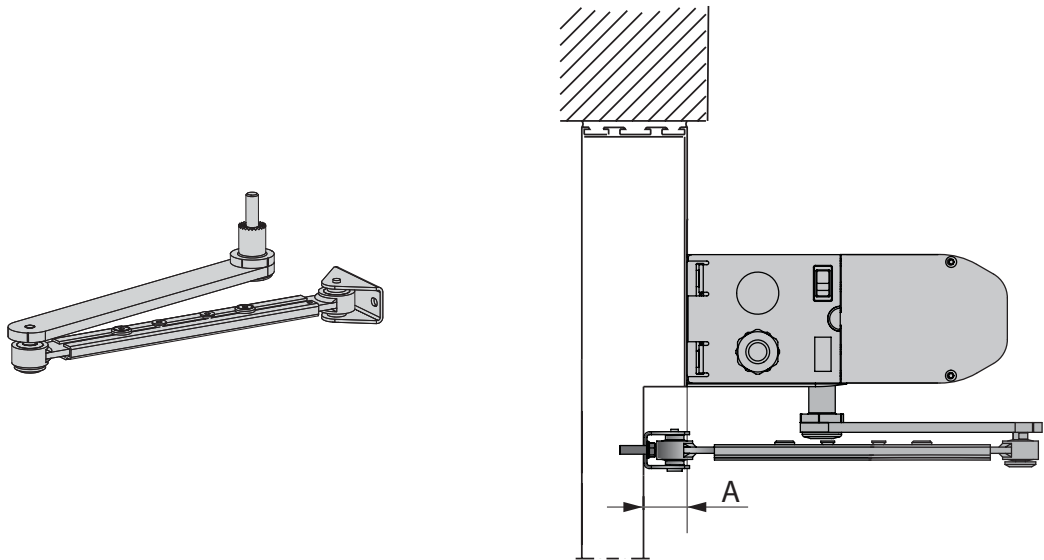

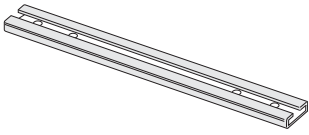
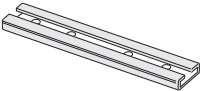
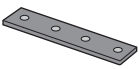
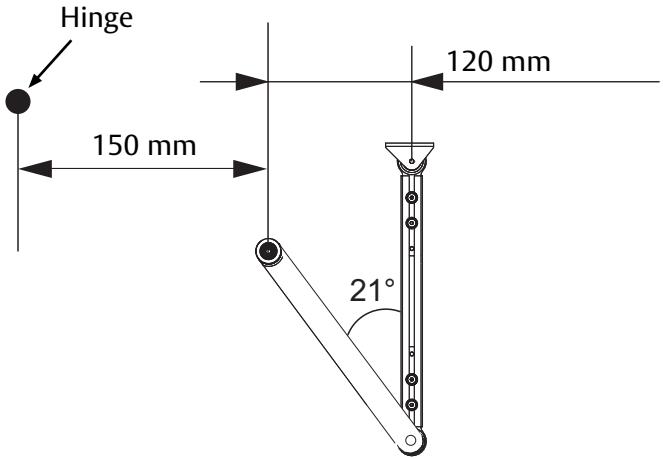
Frame depth	
<p>Extension</p>  <p>345 mm extension Art. No.: DAB805TFL</p>  <p>230 mm extension Art. No.: DAB805TFS</p>  <p>Joint part Art. No.: DAB805TKJ</p>	 <p>Hinge</p> <p>150 mm</p> <p>120 mm</p> <p>21°</p>
	A = reveal
None (Standard arm)	0 mm to 22 mm
Extension L= 345 mm	22 mm to 137 mm
Extension L= 230 mm + joint part	137 mm to 252 mm
Extension L= 345 mm + 230 mm + joint part	252 mm to 367 mm

9.2 Pulling installation with PULL-arm

This arm system is delivered with drive arm, guide shoe and door fitting. Approved for fire door application for A up to 130 mm.

DAB805PLA3, L = 400 mm (A = -20 to 130 mm; B = 150 mm, minimum door width 700 mm).

DAB805PLA4, L = 600 mm (A = -20 to 230 mm; B = 250 mm, minimum door width 1050 mm / B = 420 mm, minimum door width 1200 mm).

DAB805PLA5, L = 220 mm (A = -20 to 65 mm; B = 150 mm, minimum door width 450 mm, maximum door width 750 mm).

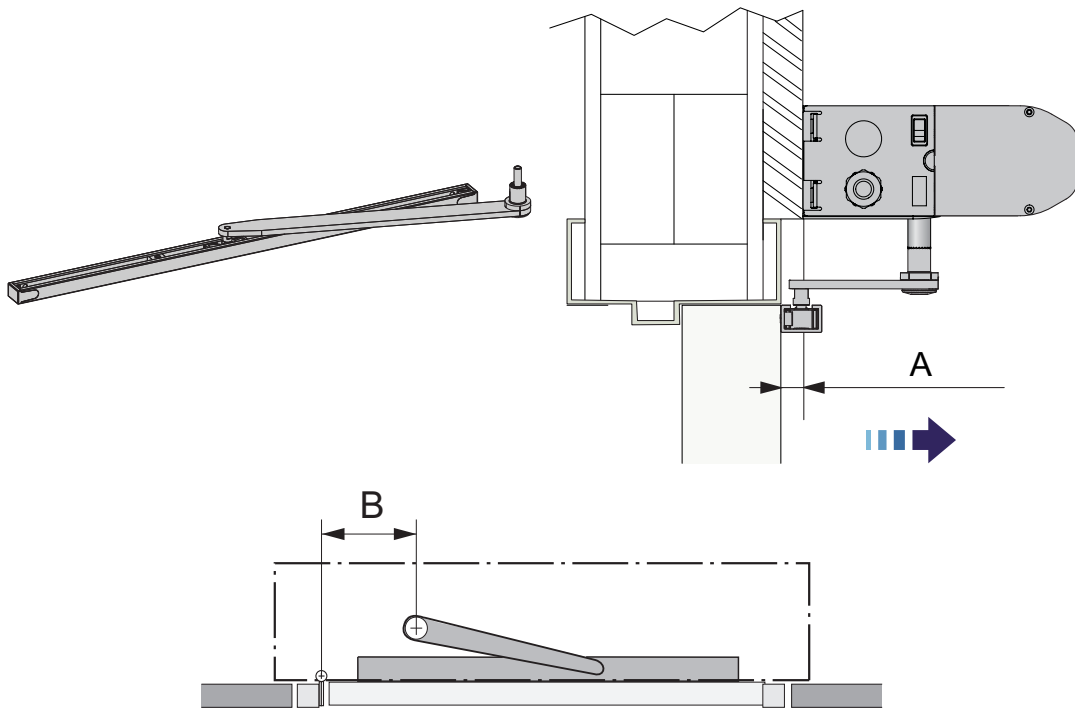

9.3 20 mm extension

Extension 20 mm for PULL and lower mounting of slide track profile.

Art. No.: DAB805PAE

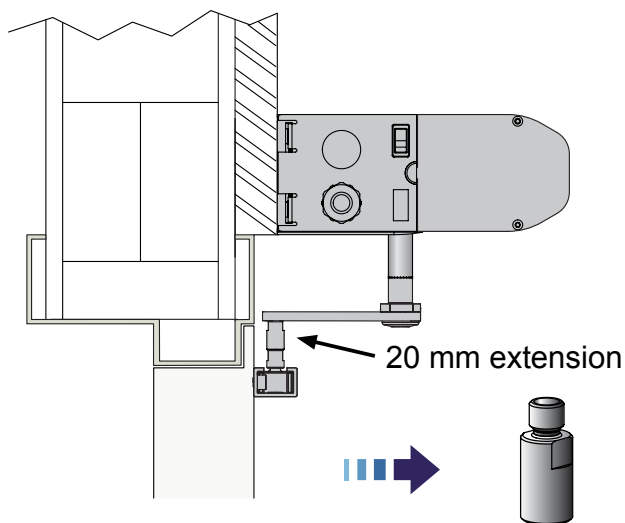

9.4 Pushing installation with PULL-arm

This arm system consists of main arm, slide track, guide shoe and shaft adapter. It can be fitted on combinations of doors and jambs (walls), where the wall thickness does not exceed approximate 114 mm / 173 mm. Dimensions given here correspond to an opening angle of 90-100°.

PULL-400, Art. No.: DAB805PLA3 (B = 150 mm)

PULL-600, Art. No.: DAB805PLA4 (B = 420 mm)

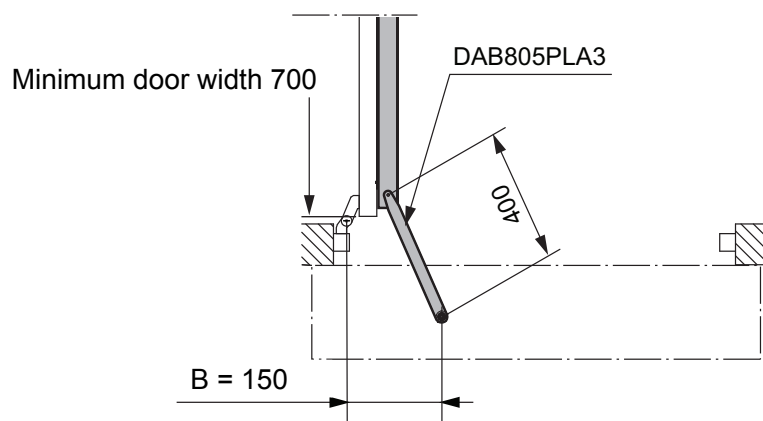
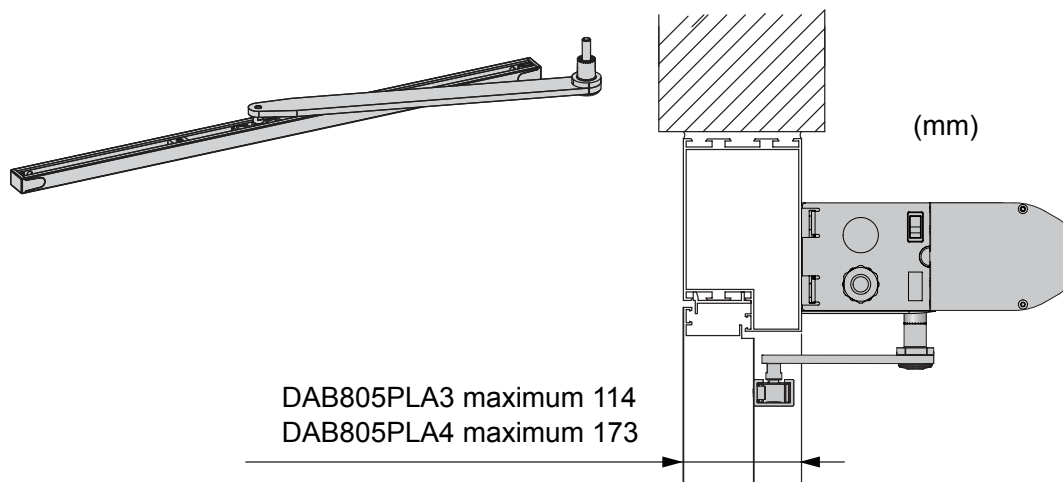

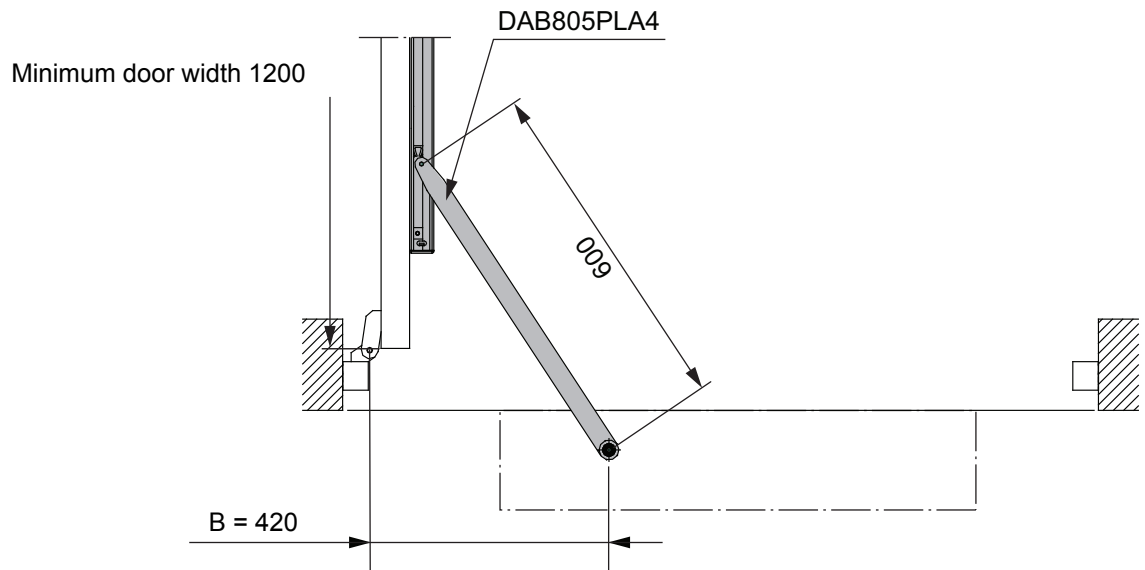

Note1! Low speed distance and closing will increase.

Max. door opening = 100°

Min. door width = 1200 mm

Note2! Dip switch 6 = OFF and 7 = OFF.

Note3! Choose Extended arm selection level 5 any status number 9 - 16.

9.5 Double acting kits

One way automatic opening and opposite way panic opening.

Identify the automatic opening, sliding PUSH or PULL. Opposite direction will be the manual break-away.

RH/DIN, DAB805DAR

LH/DIN, DAB805DAL

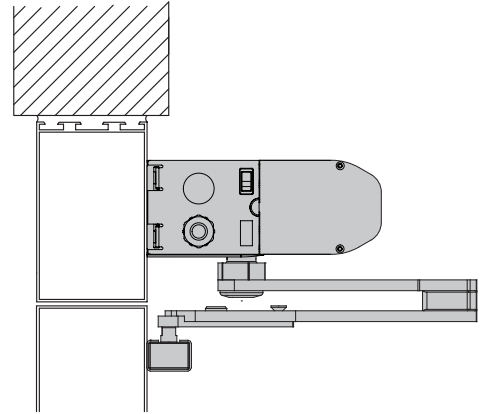
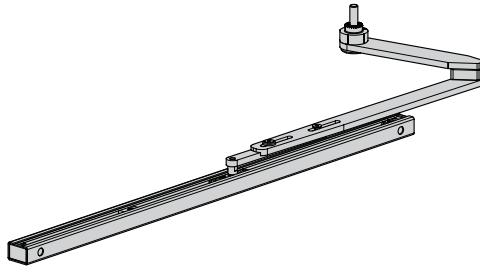

PULL

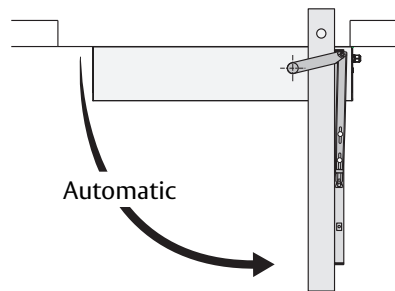

Sliding PUSH

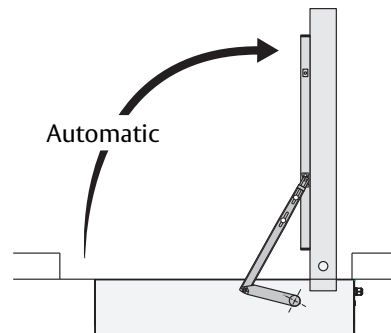

9.6 Drive shaft extension kits

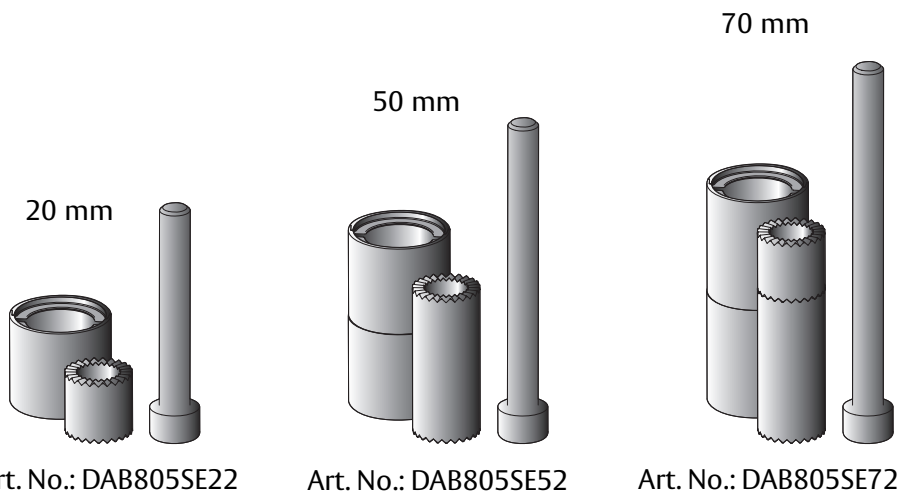

Lower adapter M10, used for 20 mm lower installation height.

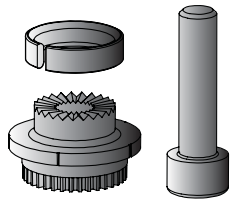

Art. No.: DAB805LA

10 Options

10.1 Program selector

10.1.1 4-position switch COM400MHB/MKB (operates the electric lock)

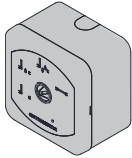

Art. No.:
COM400MHS/MKS

Position	Function
	OFF The door is closed. The door cannot be opened with inner and outer activation units. The door is locked if an electromechanical locking device has been fitted. The door can be opened with a key switch (if fitted).
	EXIT Passage from inside only. The door is normally locked if an electromechanical locking device has been fitted. The door can only be opened with the inner activation unit and with a key switch (if fitted).
	AUTO Normal position The door can be opened with the inner and outer manual and/or automatic activators. The electric strike, if fitted, is open.
	OPEN The door is held permanently open by the motor.

Note! If the door is often kept open by a wedge or magnet then select program selection OPEN or OFF, if not the operator will try to close the door, and this might damage the operator long-term.

10.2 Elbow switches

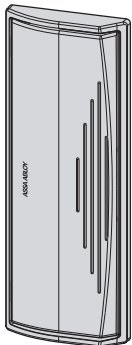

Art. No.:
PFP1
PFP2

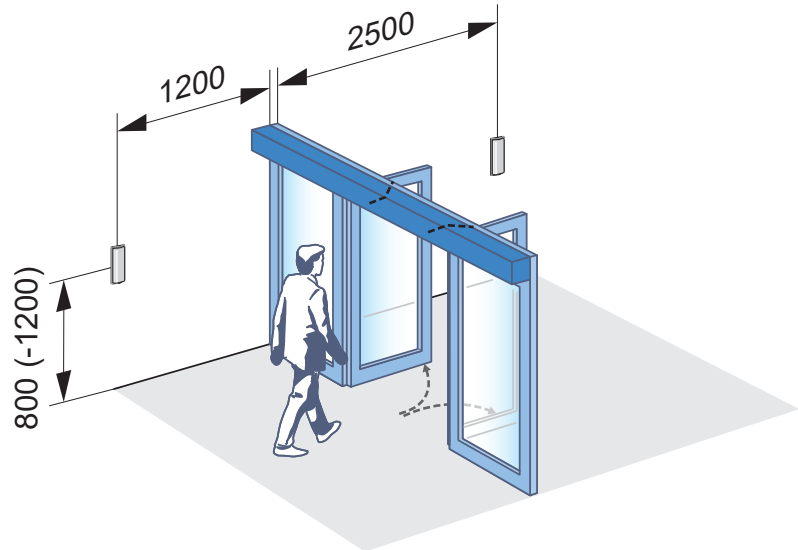

10.3 Sync cable for double doors (synchronizing of 2 operators)

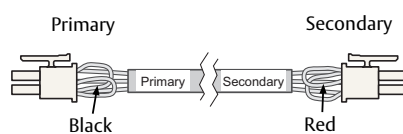

Art. No.: DAB905SYN

Note! The connection/markings of the sync cable determines which of the operators is the primary and secondary.

10.4 Coordination unit

To coordinate rebated doors in a double door installation and to make sure the doors are closed in right order. See page 66 for installation and adjustment.

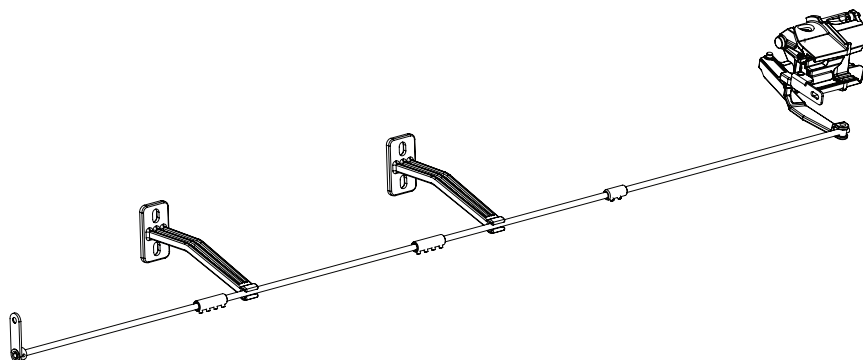

Art. No.	Description
DAB905COU	Coordinator top assembly
DAB805ROD	Rod kit

10.5 LED Cable

External status indicator LED

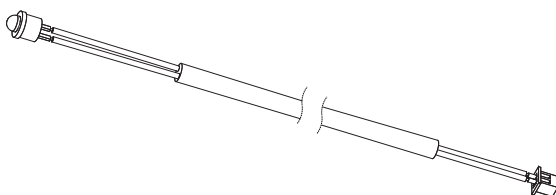

Art. No.: DAB905LED

10.6 Battery backup unit

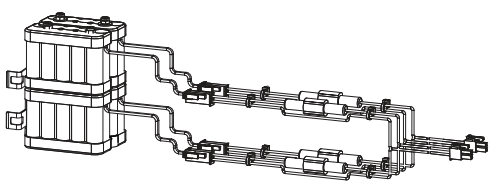

Art. No.: DAB905BAT3
Refer to drawing 1020459 for installation.



Disconnect mains when replacing battery.



Risk of battery explosion if wrong type of battery is used.

10.7 Cover piece kit

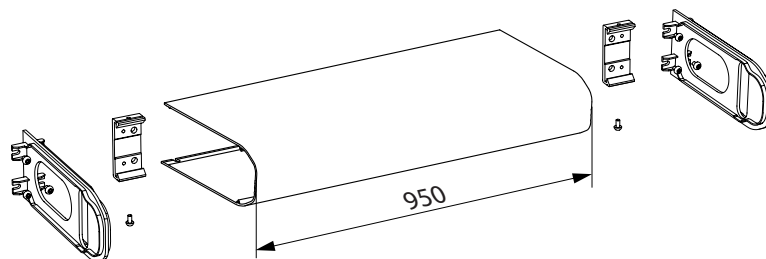

Art. No.: DAB805CMP1

10.8 Closing time board kit

To fulfill the DIN 18263-4 standard it is necessary to mount and connect this board to the lock kick.



Article number: DAB905CBK

10.9 Fire kit

For fire door installations.

Containing a smoke detector ORS142W with silver cover, a Reset & Indication Device, Closing brake kit and a three pole connection cable harness.

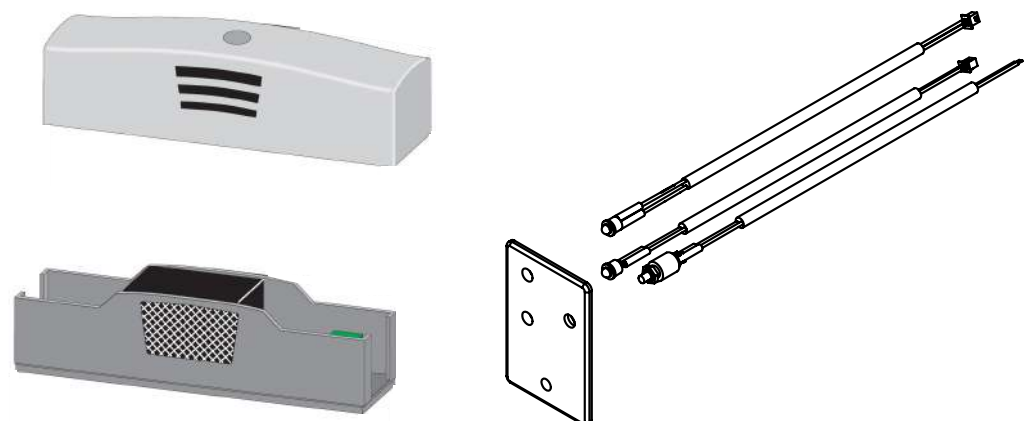

Article number: DAB905FIK

10.10 Labels

Label kit- including all below



Emergency break-out, DIN right door



Emergency break-out, DIN left door



Activation by disabled people



Operator designed for disabled people



Supervision of child

11 Pre-installation

11.1 General tips/Safety concerns



In all instances, where work is being done, the area is to be secured from pedestrian traffic to prevent injury.



In all instances, where work is being done, the main power is to be removed to prevent injury.

- Make sure that the power is off before installing.
 - If there are sharp edges after drilling the cable outlets, chamfer the edges to avoid damage to the cables.
 - The cables must avoid sharp edges and moving parts. Attach the cable with cable ties along the cable routing.
 - For enhanced security and vandalism protection, always mount the operator access in the interior of a building whenever possible.
 - Make sure the ambient temperature is in the range specified on page [Technical specifications](#).
 - Make sure that the door leaf and the wall are properly reinforced at the installation points.
 - Unpack the operator and make sure that all parts are delivered in accordance with the packing note and that the operator is in good mechanical condition.
 - Ensure proper material is being used for the door leaves and that there are no sharp edges. Projecting parts shall not create any potential hazards. If glass is used bare glass edges shall not come in contact with other glass. Toughened or laminated glass are suitable glasses.
 - Ensure that entrapment between the driven part and the surrounding fixed parts due to the opening movement of the driven part is avoided. The following distances are considered sufficient according to EN 16005 to avoid entrapments for the parts of the body identified;
 - for fingers, a distance greater than 25 mm or less than 8 mm
 - for feet, a distance greater than 50 mm
 - for heads, a distance greater than 200 mm^a
 - and for the whole body, a distance greater than 500 mm
- ^a To comply with EN 60335-2-103:2015 a distance greater than 300 mm is needed
- Danger points shall be safeguarded up to a height of 2.5 m from the floor level.
 - The operator shall not be used with a doorset incorporating a wicket door.
 - Installation might require external doorstep if door is exposed to high windload or external forces.
 - The Arm adaptor is designed with a shear-off break-point designed to protect the operator in case of door vandalism or other high external forces.
If the adaptor is broken, it is important to cease using the operator to avoid wearing down the spline-teeth of the drive unit.

11.2 Operator/Door handing

Operator/Door handing (DIN Right or DIN Left) is determined by which side the hinges are mounted seen from the swing side.

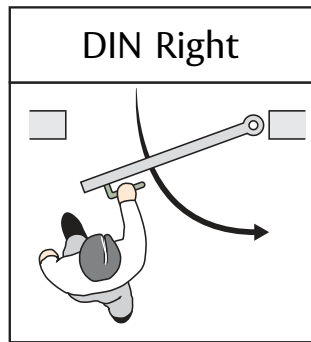
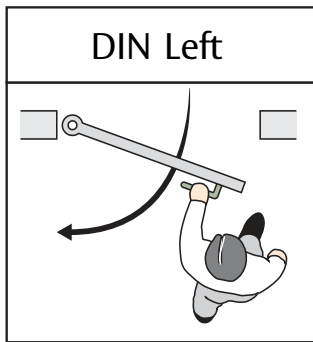

11.3 Installation examples

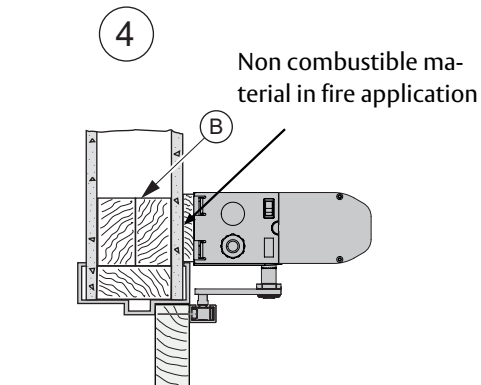
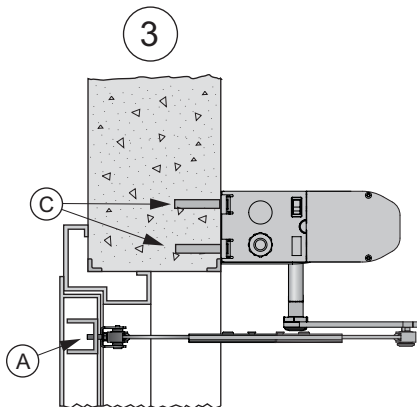
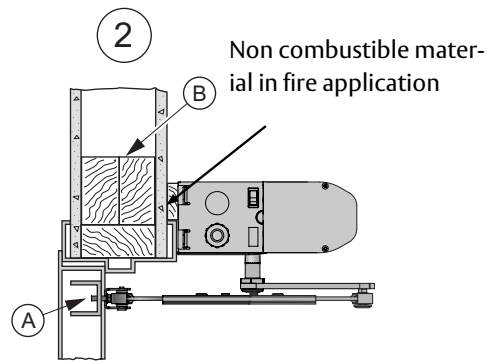
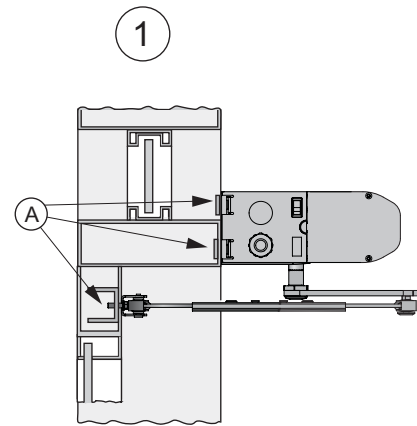

- 1 Aluminum profile system
- 2 Plasterboard wall
- 3 Reinforced concrete wall and brick wall
- 4 Plasterboard wall

- A Steel reinforcement or rivet nut
- B Wood reinforcement
- C Expansion-shell bolt (for brick wall min. M6x85, UPAT PSEA B10/25)

11.4 Fastening requirements (but not included)

Base material	Minimum requirements of wall profile*
Steel	5 mm**
Aluminum	6 mm***
Reinforced concrete	Minimum 50 mm from the underside
Wood	50 mm
Brick wall	Expansion-shell bolt, minimum M6x85, UPAT PSEA B10/25, minimum 50 mm from the underside

* Ditec minimum recommended requirements. Building Codes may give different specifications.

** Thinner wall profiles (3 mm to 5 mm) must be reinforced with rivet nuts.

*** Thinner wall profiles (4 mm to 6 mm) must be reinforced with rivet nuts.

11.5 Tools required

- Open-end spanner 16 mm
- Metric Allen keys 1.5, 2.5, 3, 4, 5 and 6 mm
- Torque wrench 80 Ncm, 8 Nm, 14 Nm and 50 Nm
- Allen key 1.5, 2.5 and 3 mm with spherical tip
- Torx T10 and T20
- Tool for screw between cover and backplate
- Flatblade screwdriver (potentiometer and terminal size)
- Screwdriver (Philips size 2)
- Nut driver 5 and 7 mm
- Measuring tape
- Power drill and set of drill bits
- Center punch
- Wire stripper
- Silicone sealant
- Installation and Service Manual (this manual)

Note! Measuring equipment used in the field does not have to display the actual values, but the chosen setpoint shall be readable. Accuracy shall be at least $\pm 10\%$.

Tools shall be calibrated at least once per year.

12 Mechanical installation

The operator is mounted on either side of the door header depending on type of doors. The door is controlled with a push or pull arm system.

If a coordination unit is to be installed on a double door installation, mount the coordinator base with rotor before mounting the transmission unit, see page [66](#).

Note! Consider all power wire entry locations and signaling wires before preparing back plate.

Make sure to mount the drive unit at measurement A and the control unit at measurement B. The illustrations also show how to route the cables. If there are sharp edges after drilling the cable outlets, chamfer the edges to avoid damage to the cables.

Note! Dismantle the operator is made by making same steps but in reversed order.

Basic installation

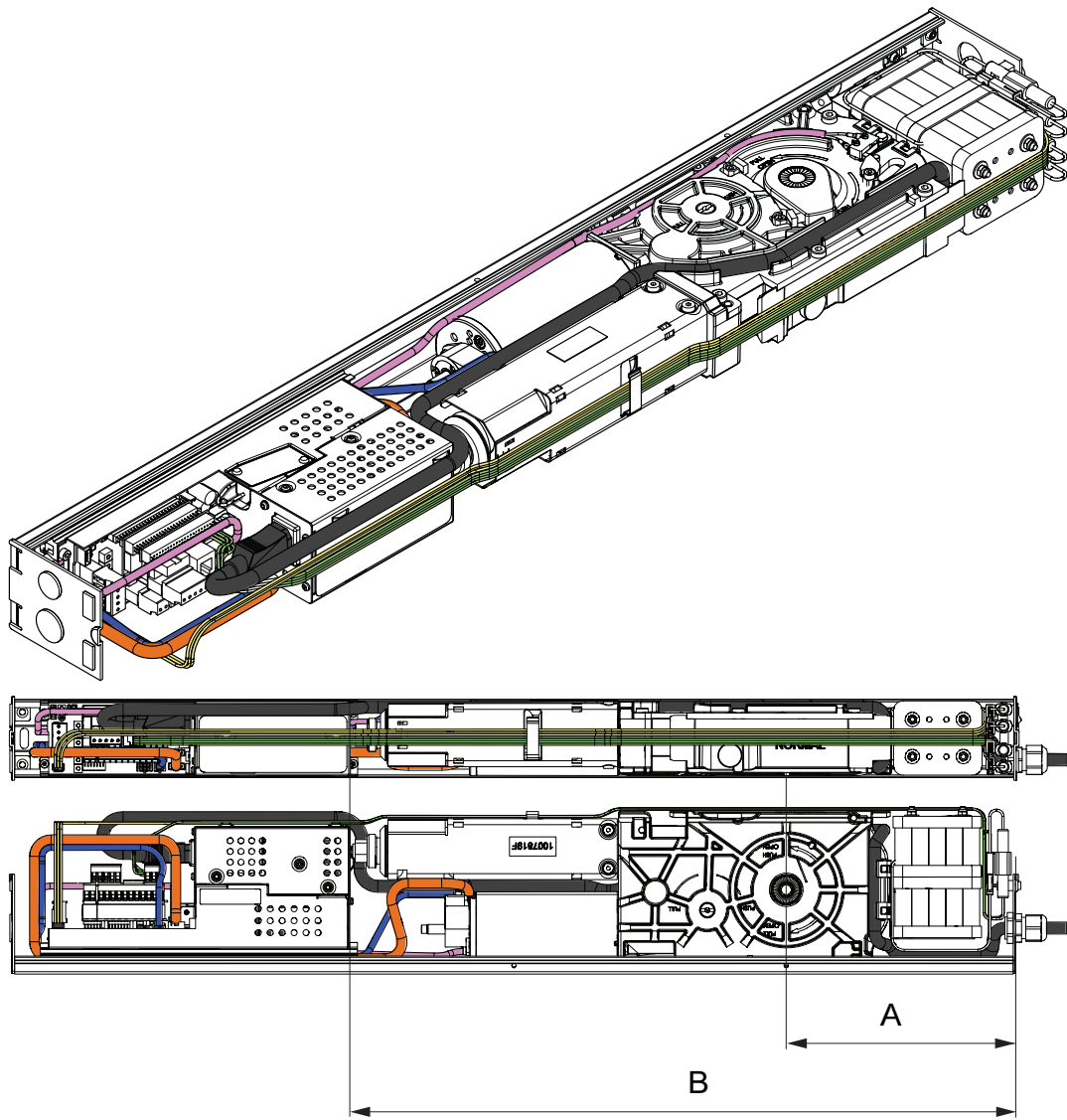

A = 192
B = 557

INVERSE installation

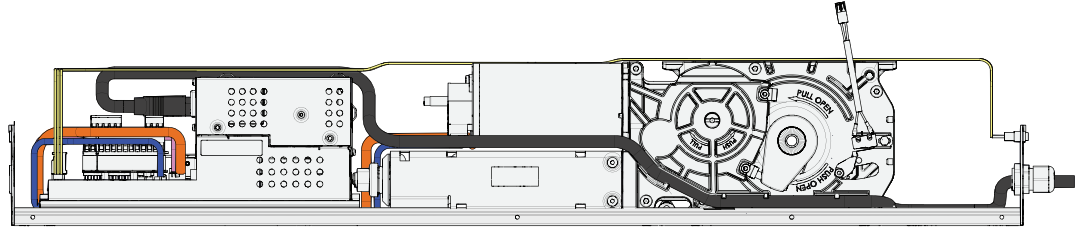
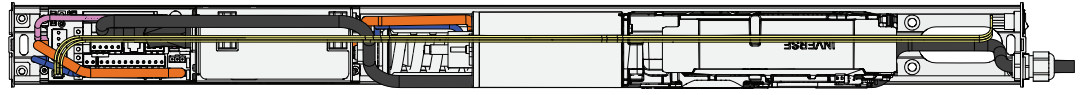
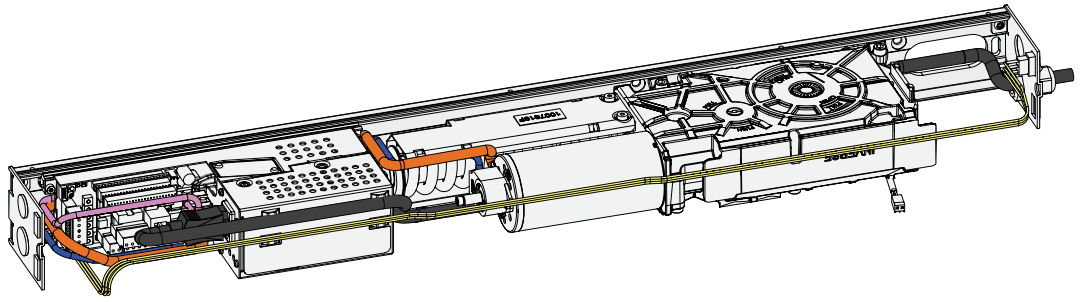

A = 192
B = 557

12.1 PUSH arm system

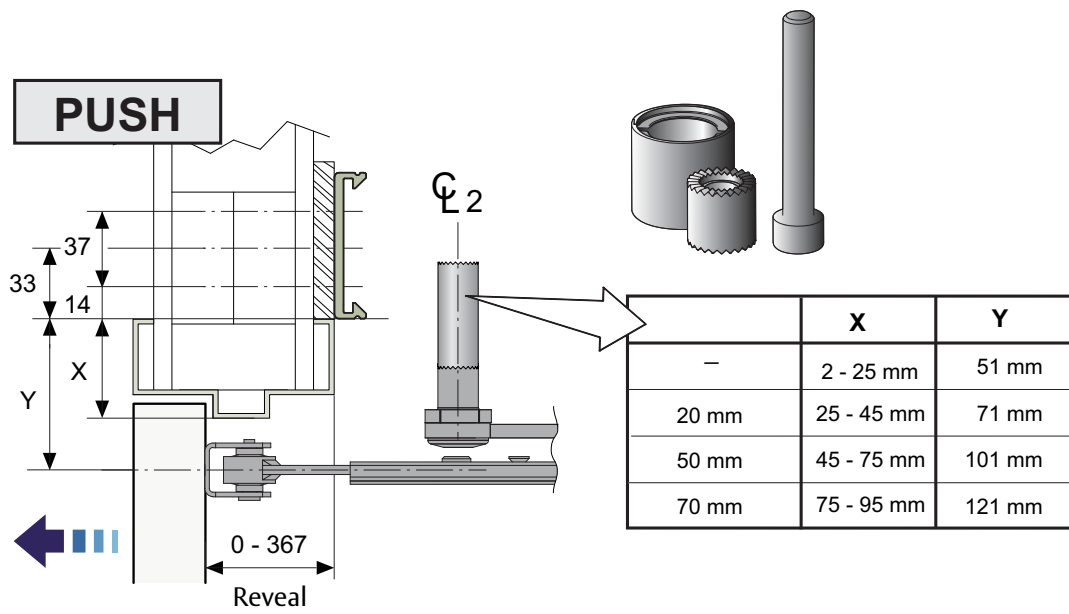

Note! Measurement Y must be reduced by 20 mm if lower adapter from kit DAB805LA is used.

Operator with PUSH arm system

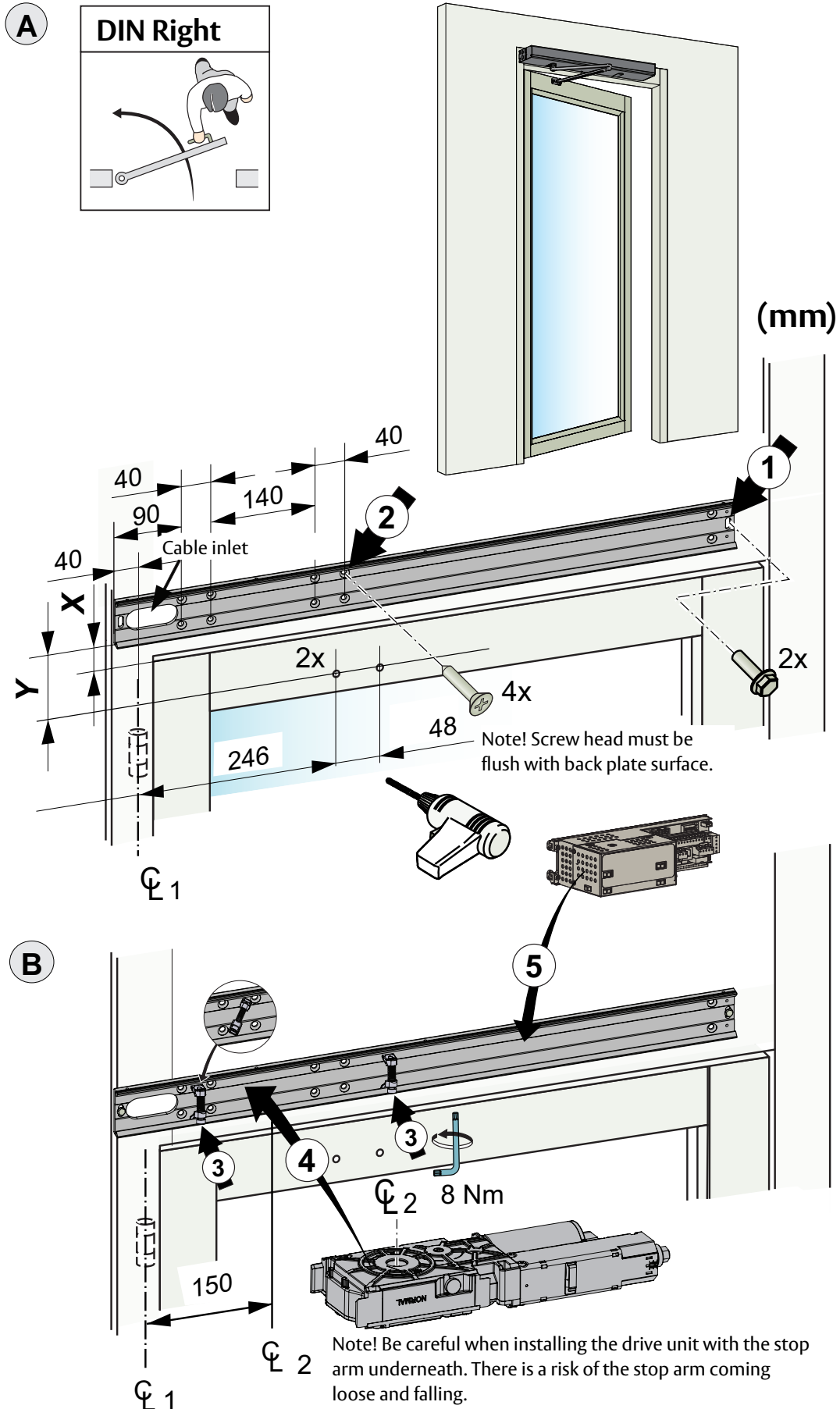

Continuous "Operator with PUSH arm system"

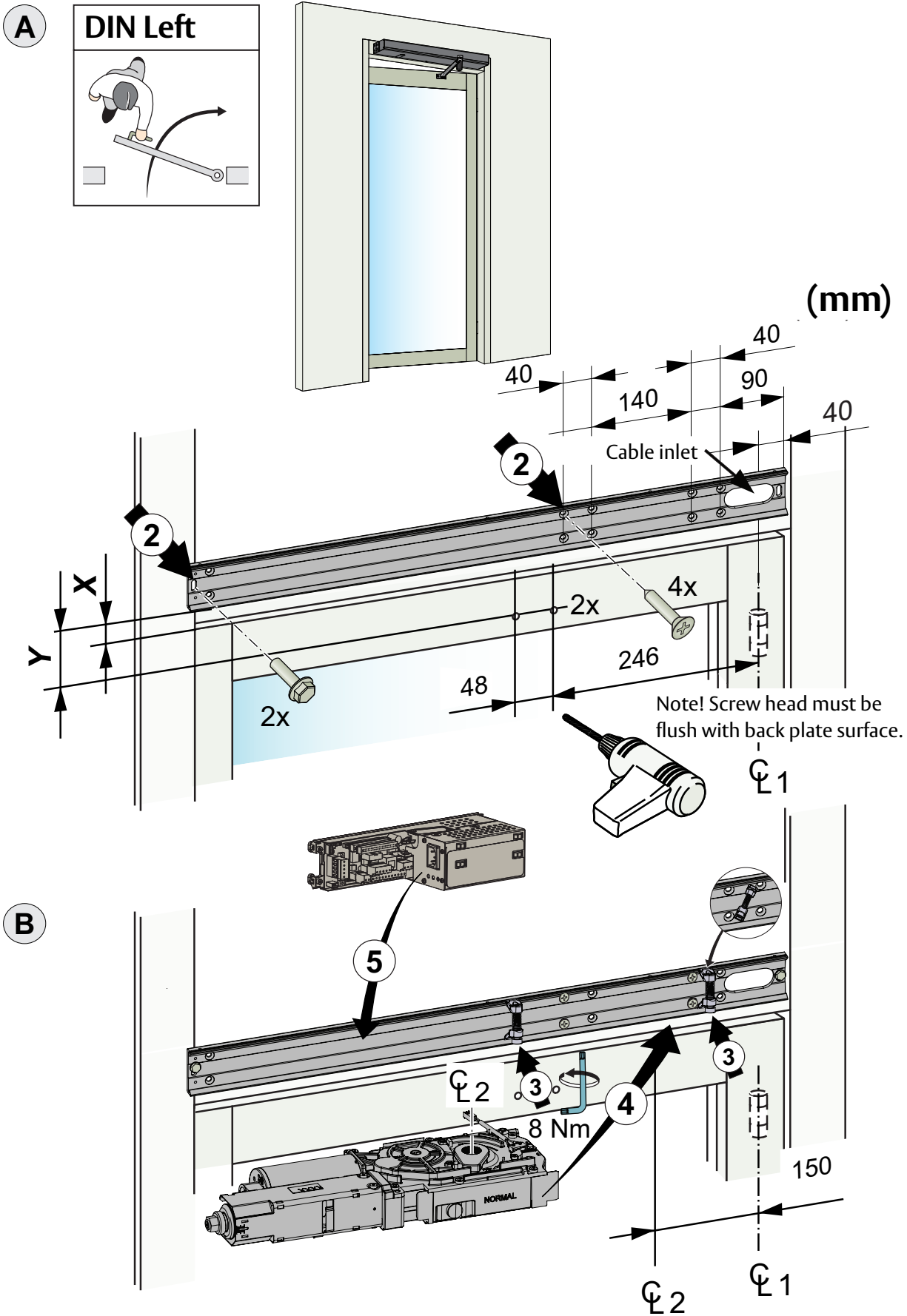

Continuous "Operator with PUSH arm system"

C DIN Left

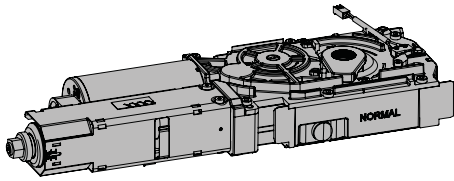

C DIN Right

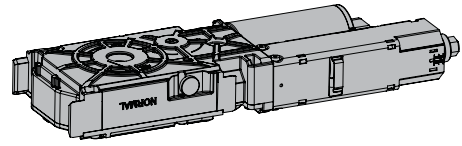

D

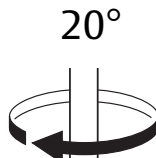

1. Pre-tension the spring

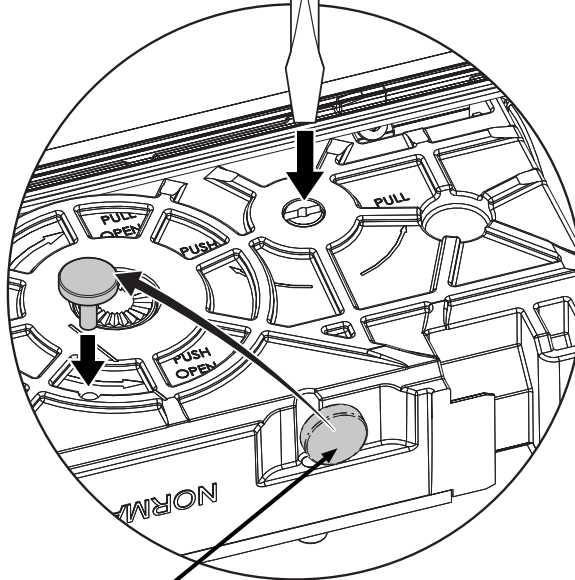

2. Secure the pre-tension by the pin

E

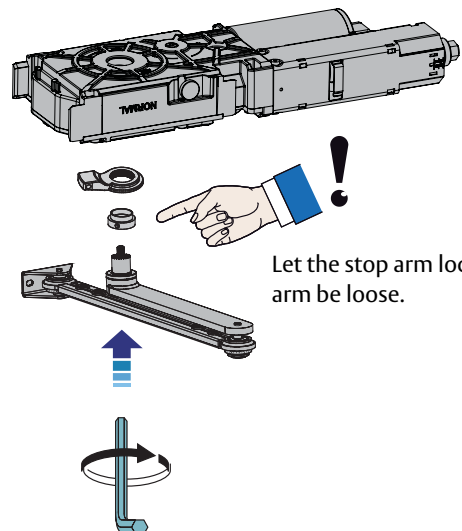
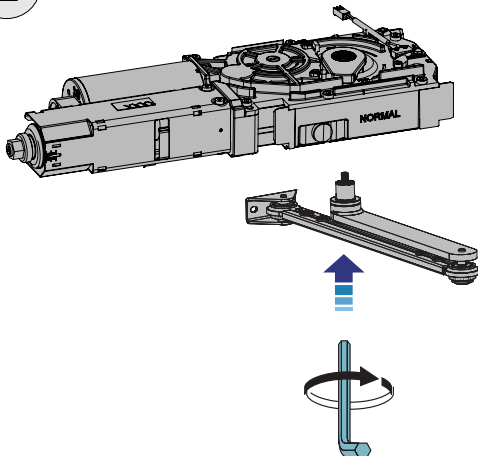

Let the stop arm locator and the stop arm be loose.

Do not tighten.

Continuous "Operator with PUSH arm system"

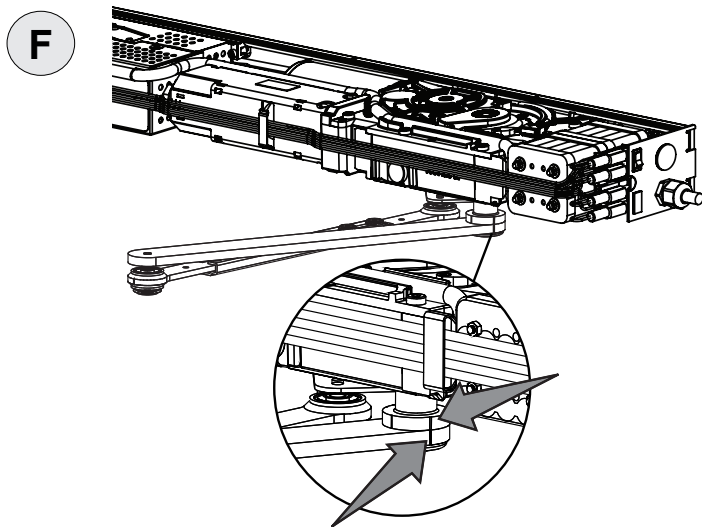

Align the marks between arm and adaptor.

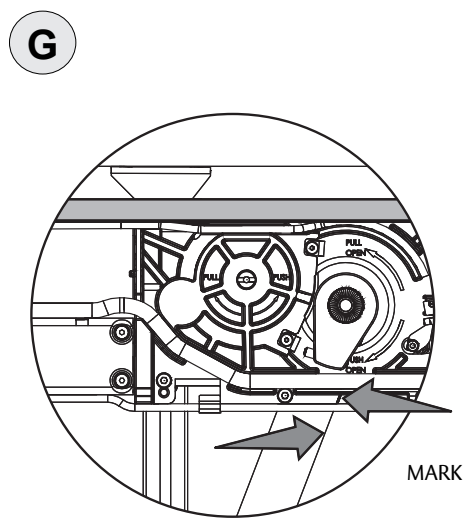

Align the arm with the operator mark.

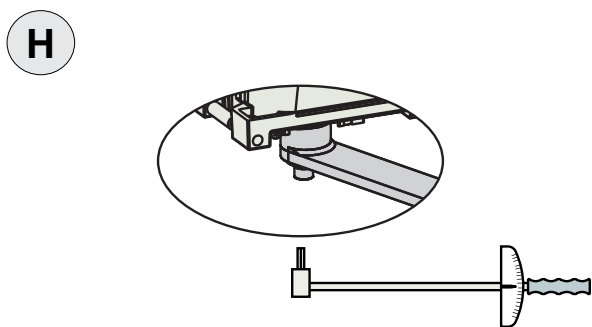

Tighten the screw temporary to keep the arm in place.

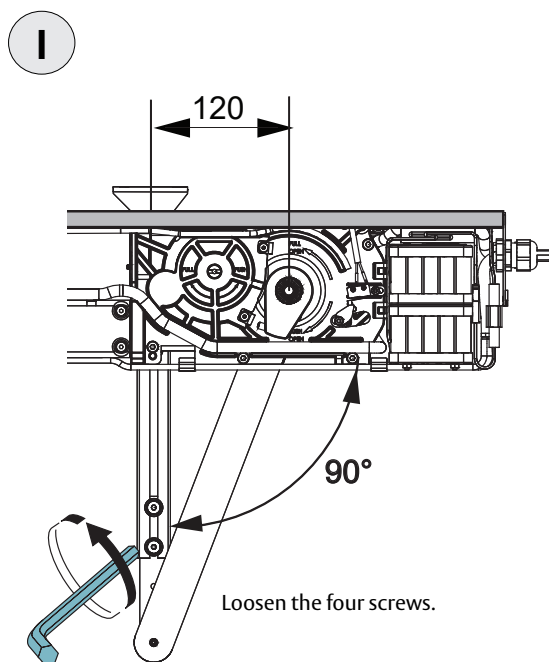

Loosen the four screws.

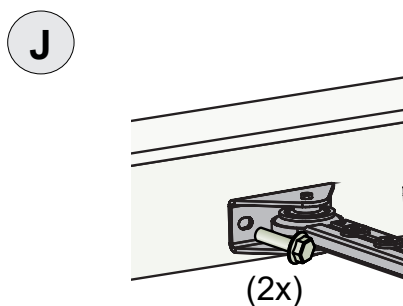

Tighten the arm system to the door.

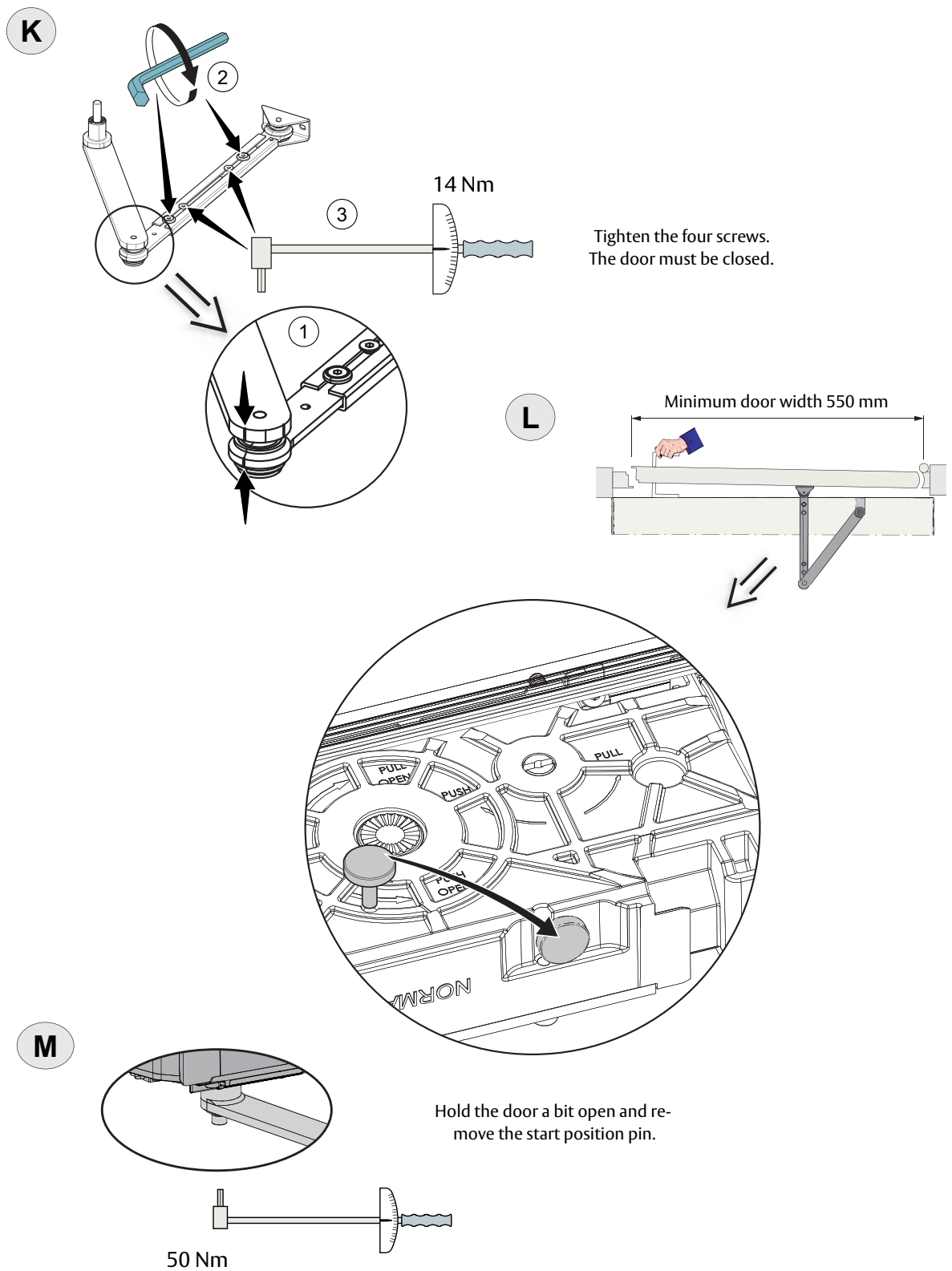

Note! Important to make sure you tighten with 50 Nm before finalizing the mechanical installation!

See the table on page 27 for available extensions.

Continue on page 74.

12.2 PULL arm system

Slim slide track

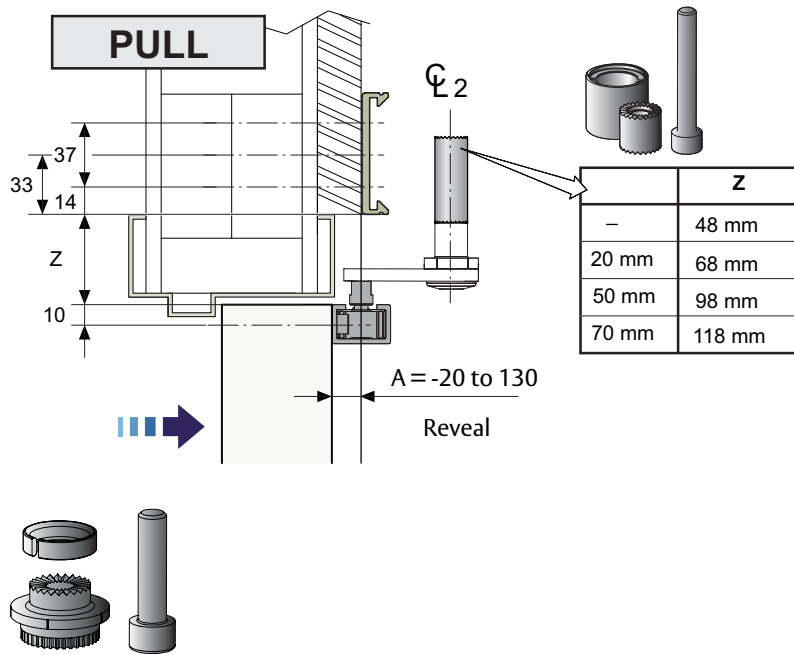

Note! Measurement Z must be reduced by 20 mm if lower adapter from kit DAB805LA is used.

Operator with PULL arm system

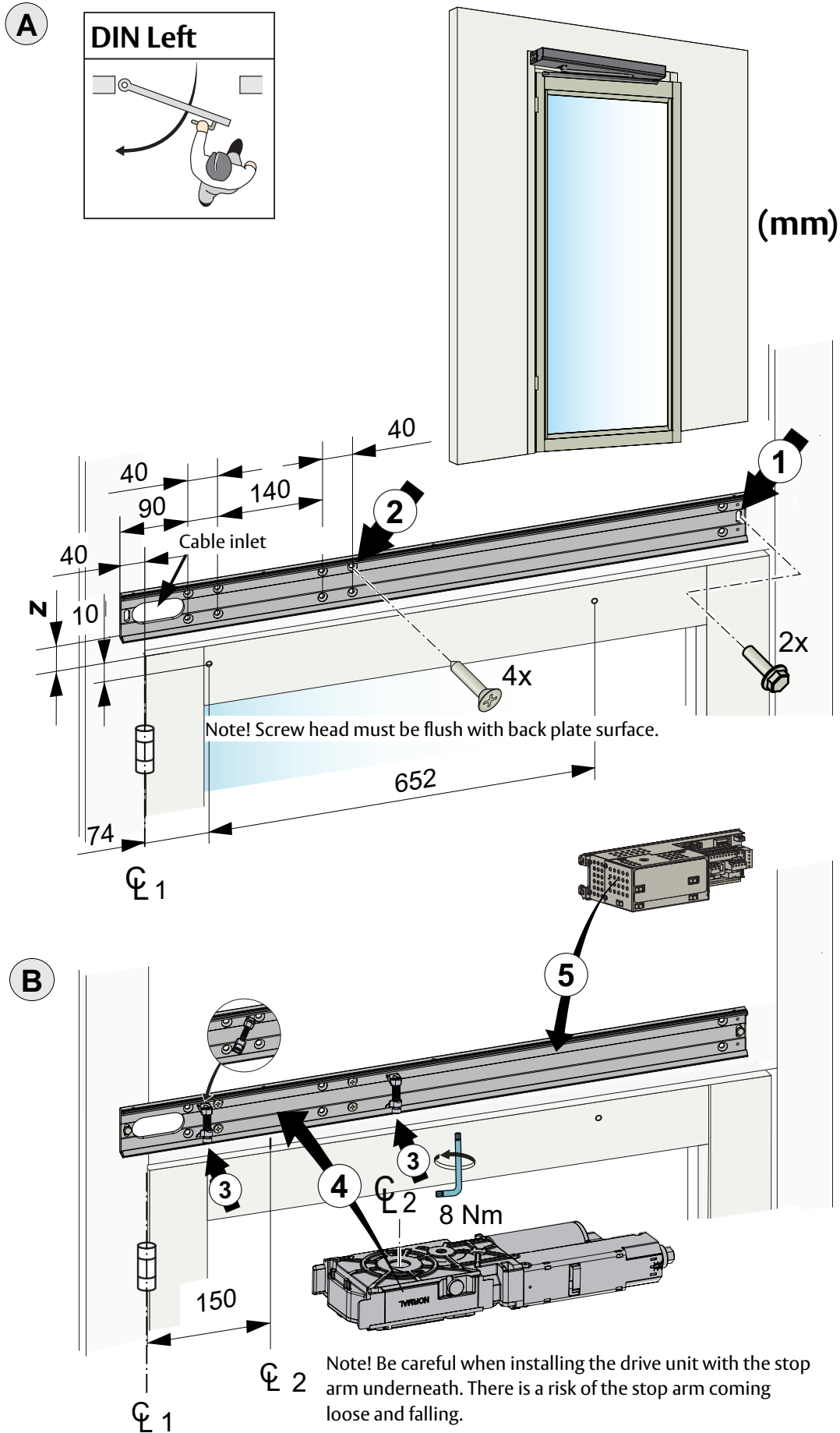

Continuous "Operator with PULL arm system"

A

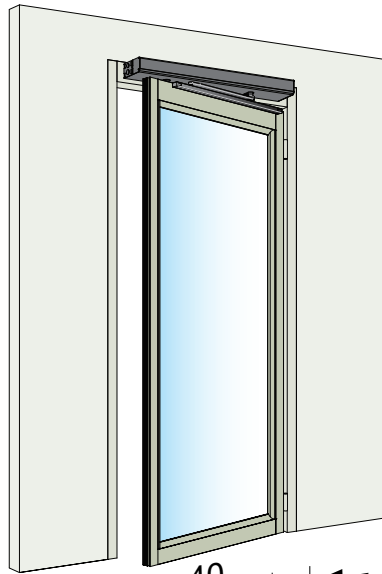
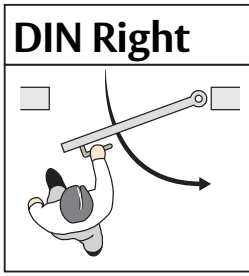

(mm)

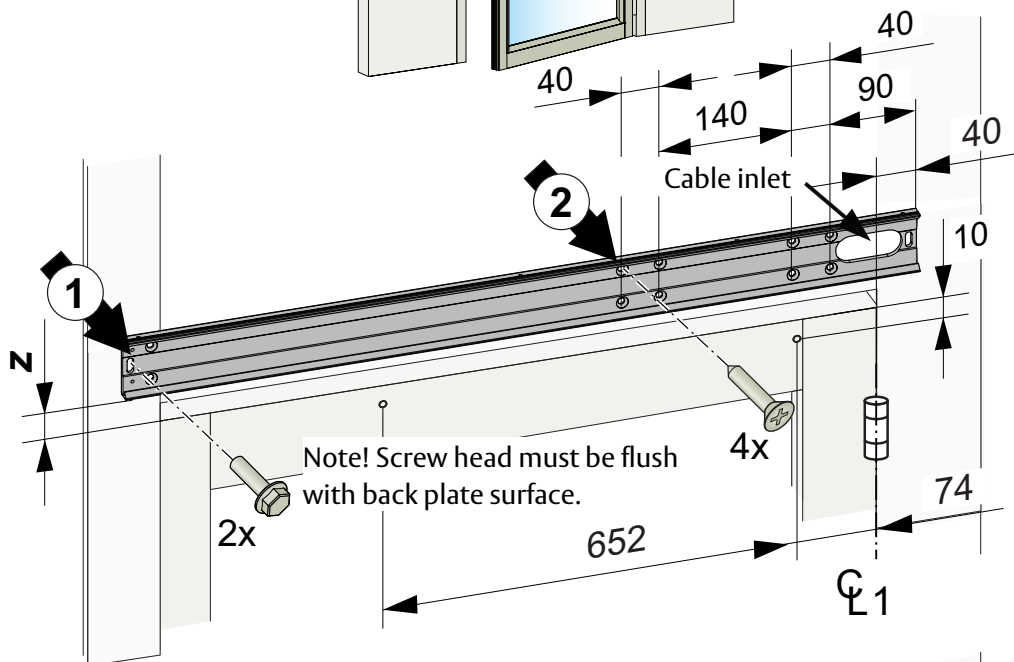

B

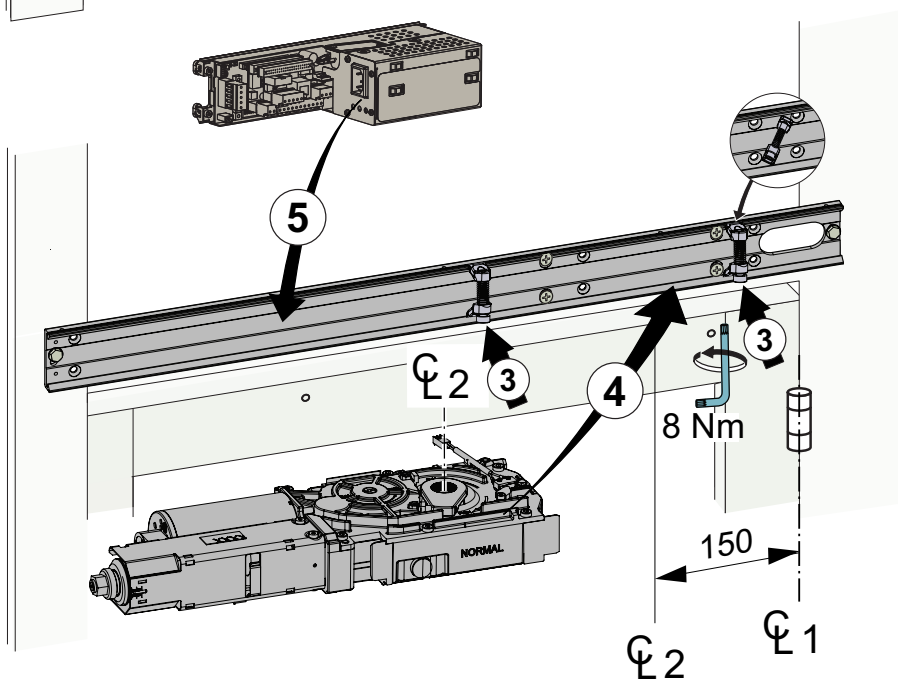

Continuous "Operator with PULL arm system"

C

DIN Right

DIN Left

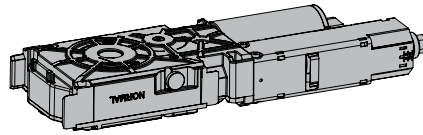
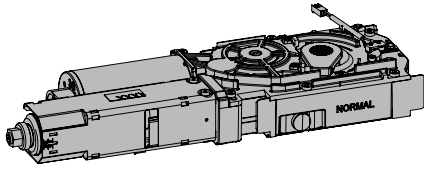

D

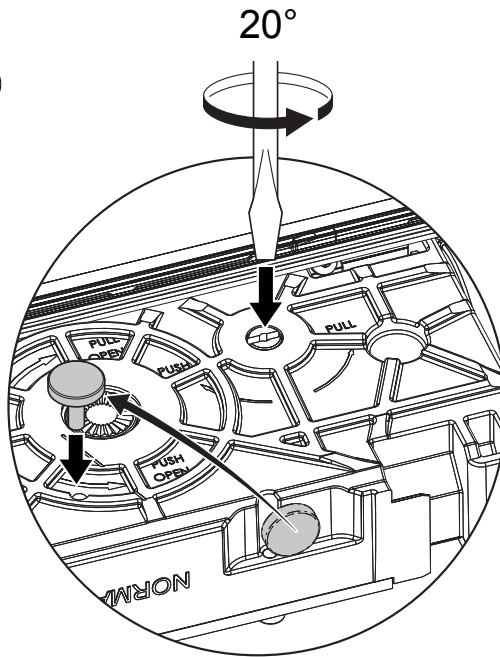

E

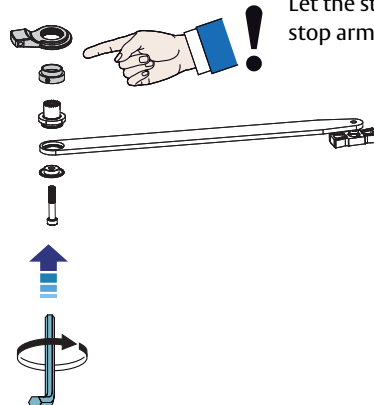
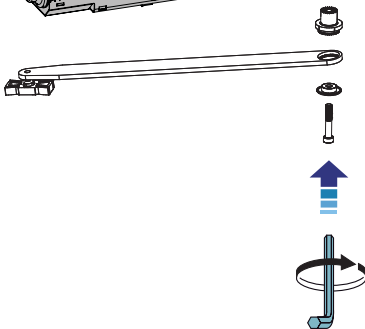
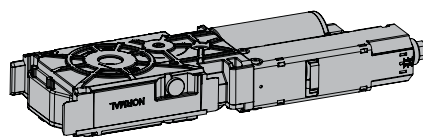
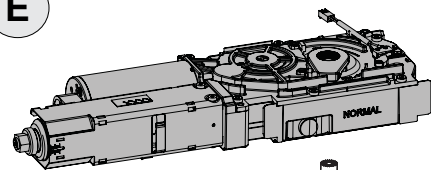

Let the stop arm locator and the stop arm be loose.

Do not tighten.

Slim slide track

Attach the slide track (1) to the door with the guide shoe (2) fitted into the track. Use appropriate screws.

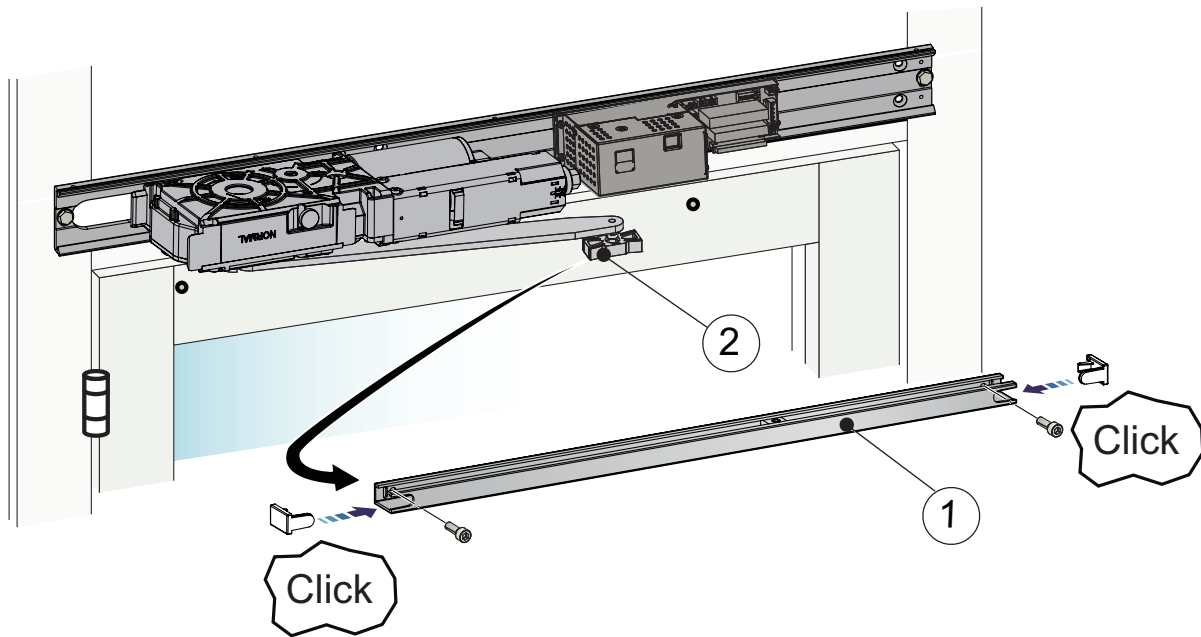

Continuous. "Operator with PULL arm system"

F

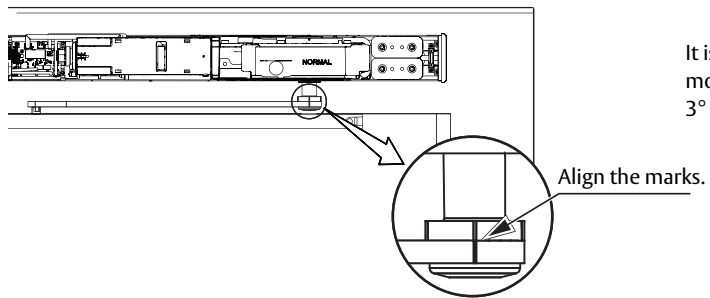

It is important to align the marks correctly. If necessary move one mark at a time. This corresponds to approx. 3° and will give a precision of $\pm 1,5^\circ$.

G

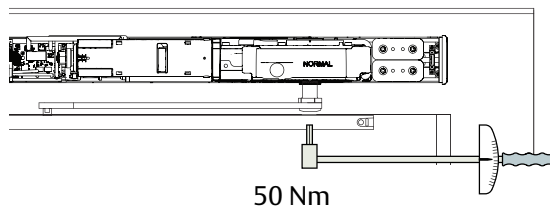

Note! Important to make sure you tighten with 50 Nm before finalizing the mechanical installation!

H

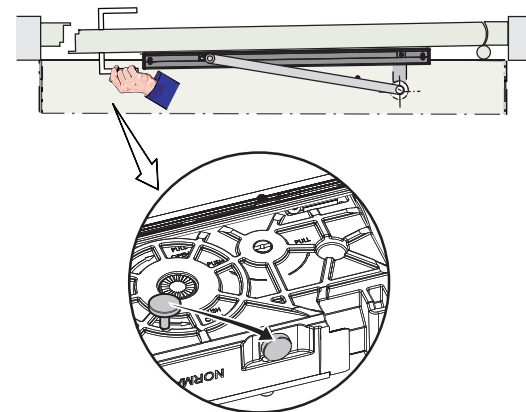

Hold the door a bit open and remove the start position pin.

12.3 Operator with sliding PUSH arm system

Slim slide track

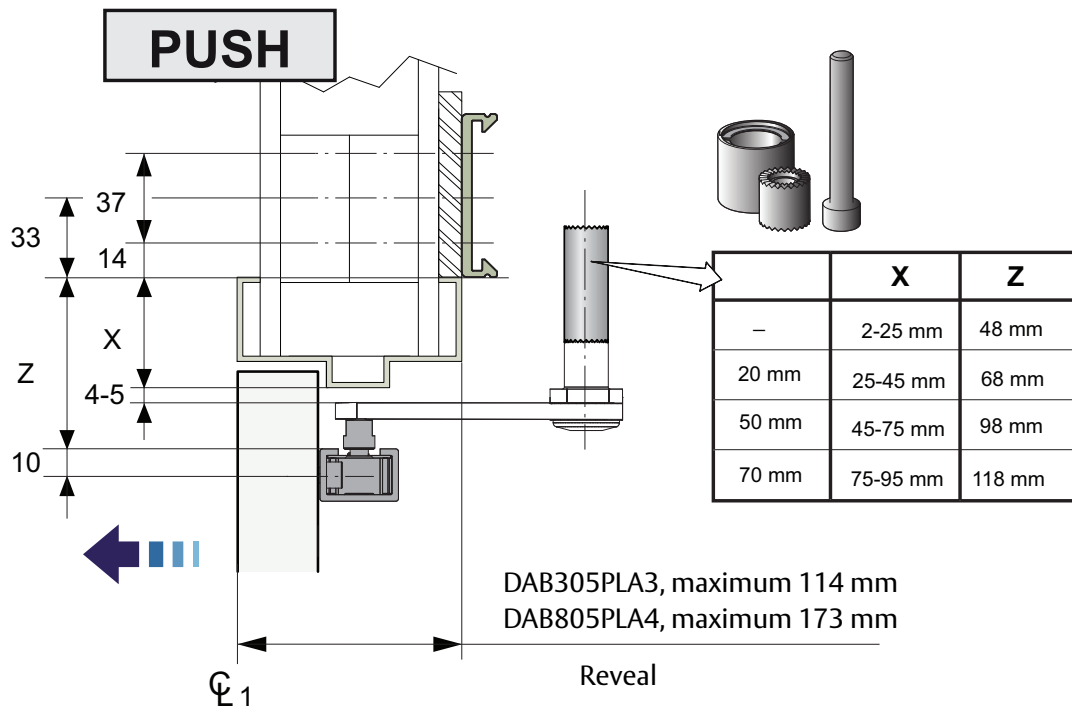

See instructions for PULL installation.

12.4 INVERSE installation with PUSH arm system

Remove the microswitch lever (1), but not the microswitch (2).

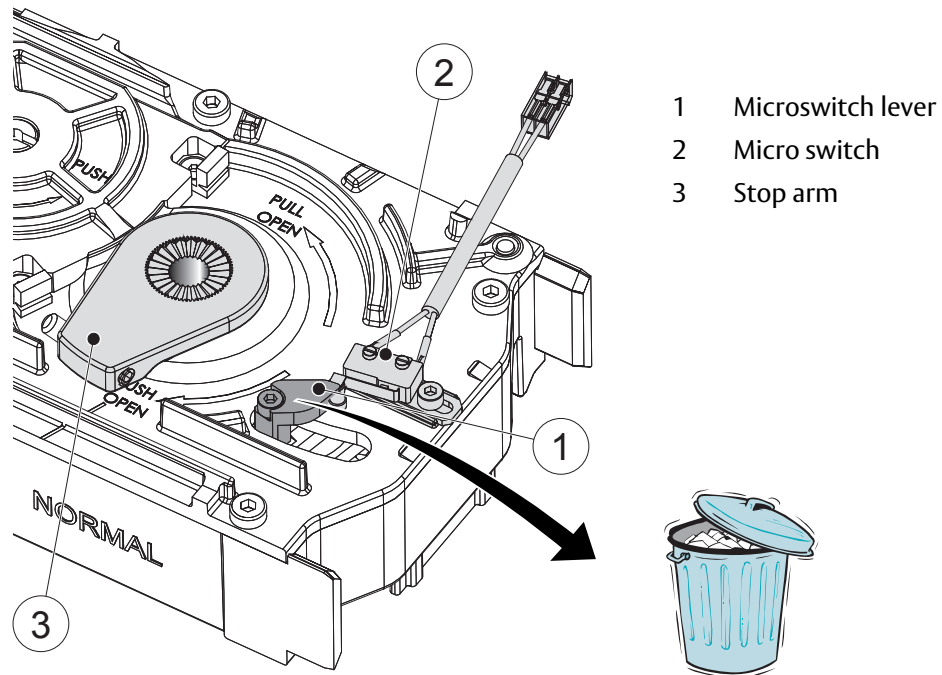

Note! Set dip switch INV to ON for INVERSE operation, see [13.1.1](#) on page 75.

For INVERSE installation (emergency opening function), maximum spring pre-tension is 7 mm or 14 mm measured between the washer and the hexagon nut. It needs to be adjusted so that the door opens and closes in a smooth way. The closing force needs to be measured and set with CLTQ to maximum 50%, to prevent motor overheating.

Note! Please pay attention to the different hexagon nuts for the measurement 7 mm or 14 mm.

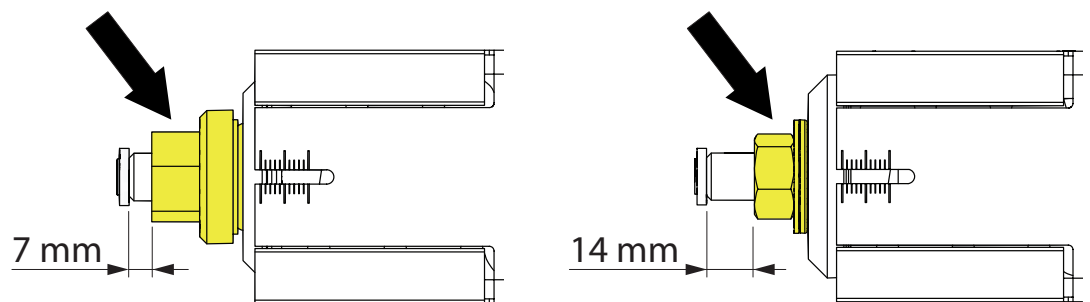

Follow below steps, note that the operator installation is same as for normal Push installations with the difference that the "INVERSE" text is visible on the drive unit when mounted correctly.

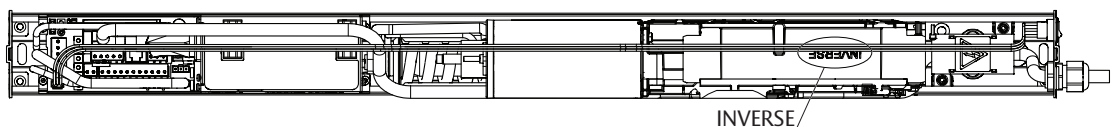

INVERSE operator with PUSH arm system

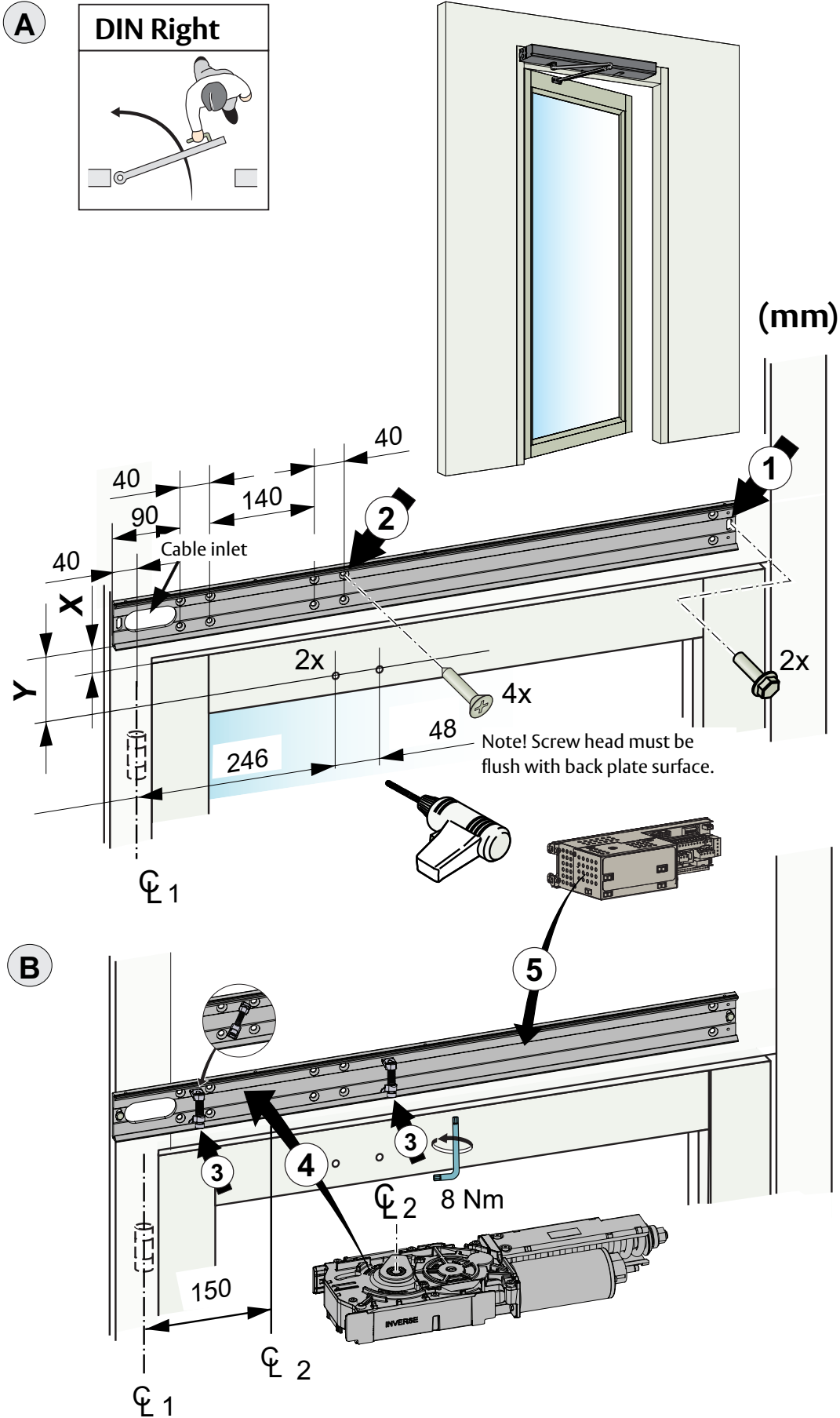

Continuous "INVERSE operator with PUSH arm system"

A

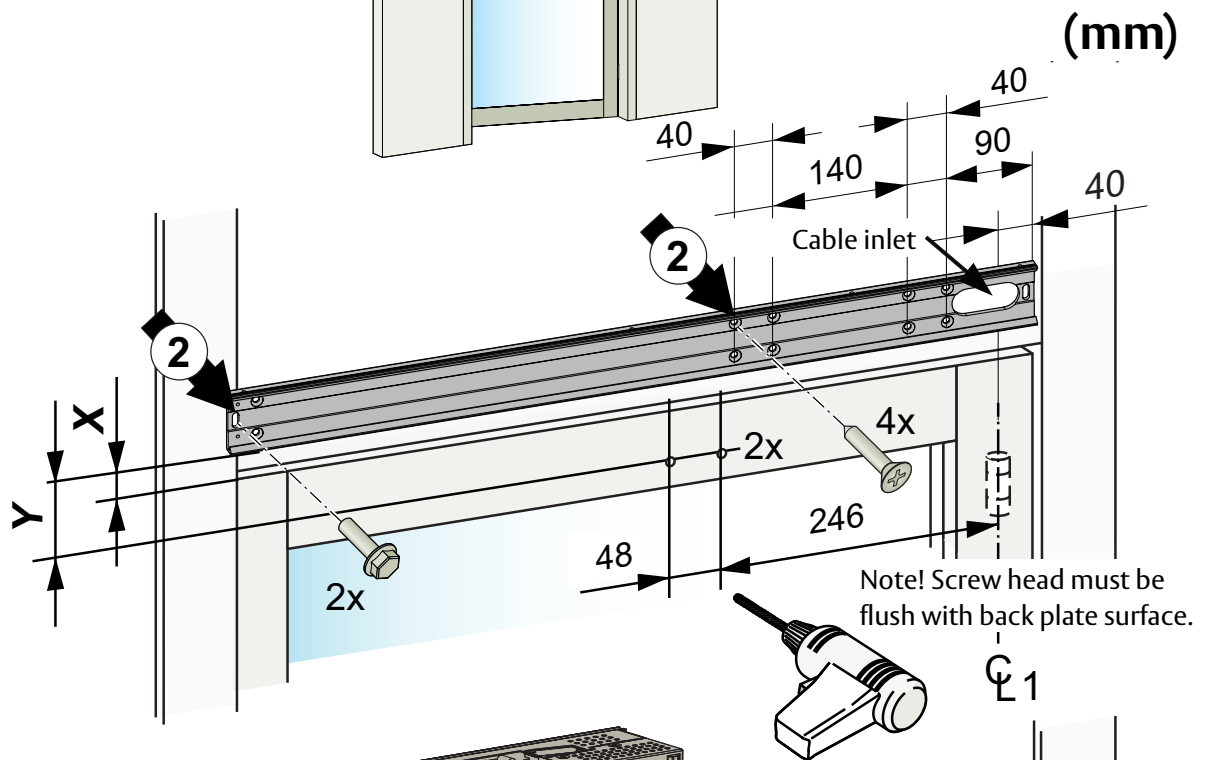
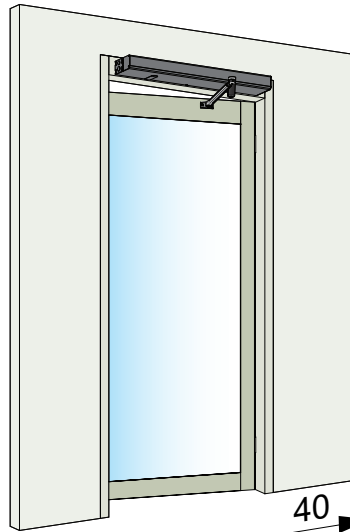
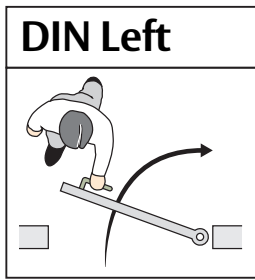

B

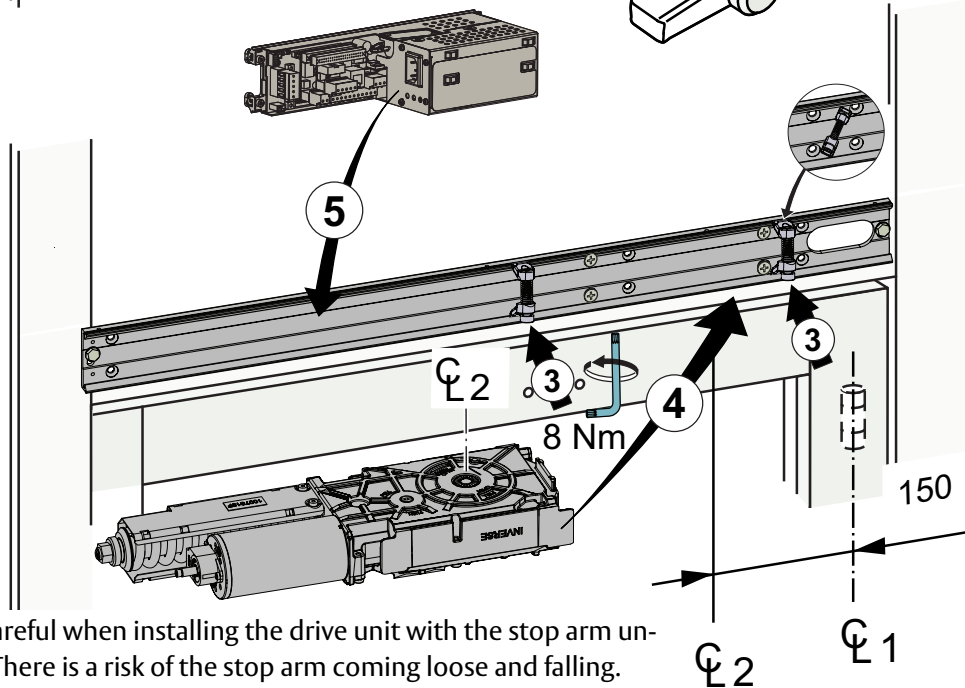

Note! Be careful when installing the drive unit with the stop arm underneath. There is a risk of the stop arm coming loose and falling.

Continuous "INVERSE operator with PUSH arm system"

C DIN Left

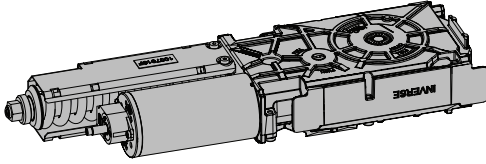

C DIN Right

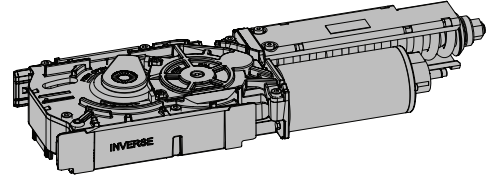

D

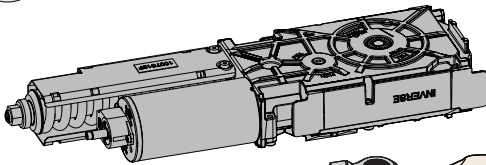

Let the stop arm locator and the stop arm be loose.

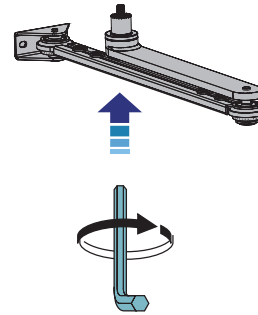
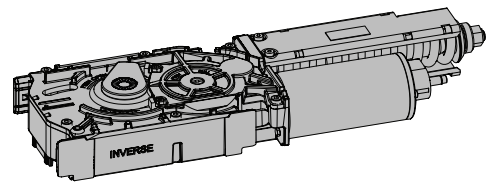
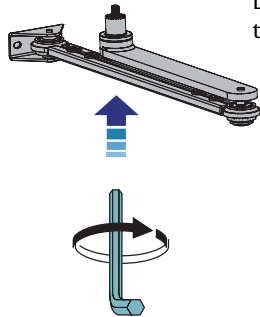

Do not tighten. Splines should not be engaged.

Continuous "INVERSE operator with PUSH arm system"

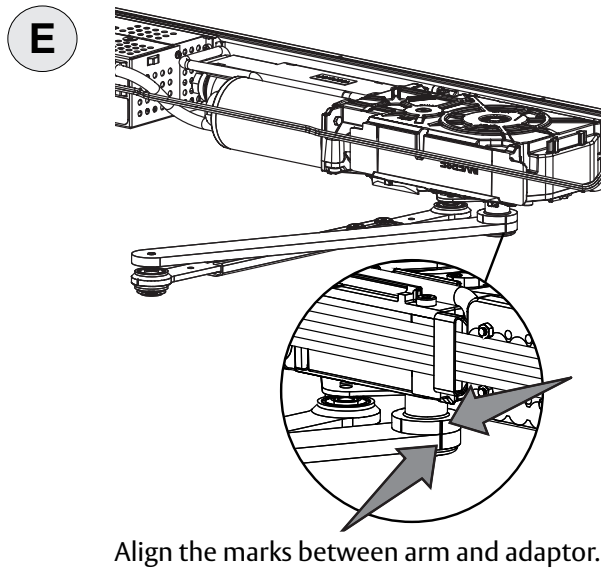

Align the marks between arm and adaptor.

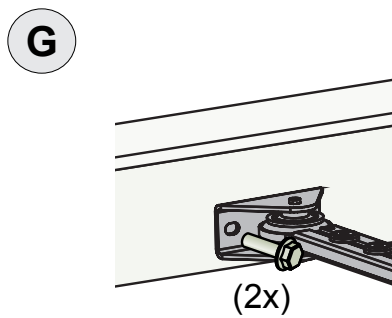
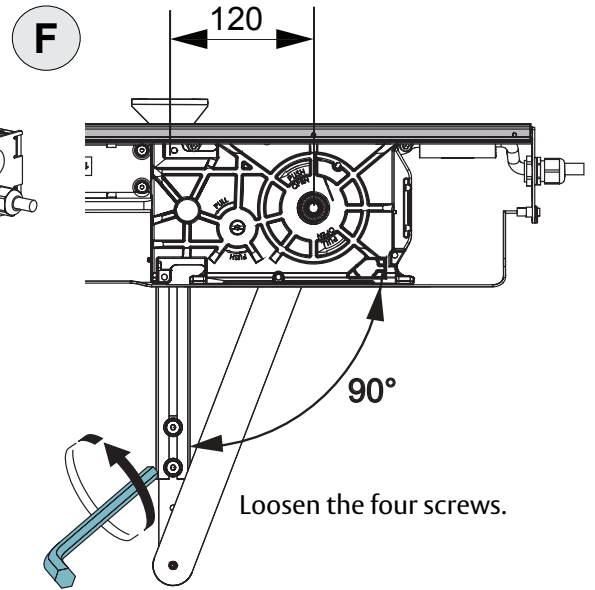

Fasten the arm system to the door.

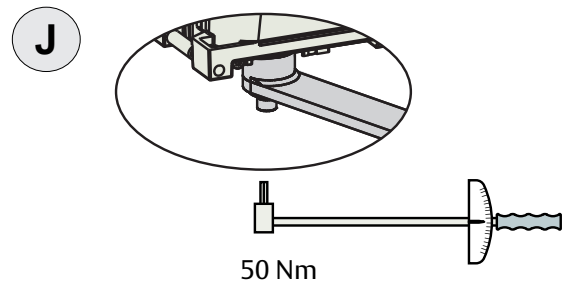
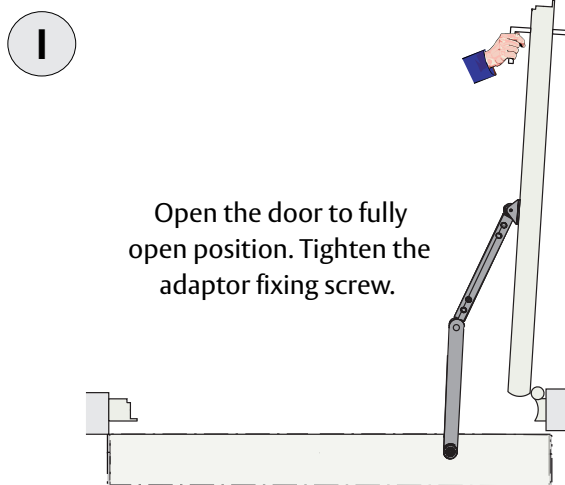
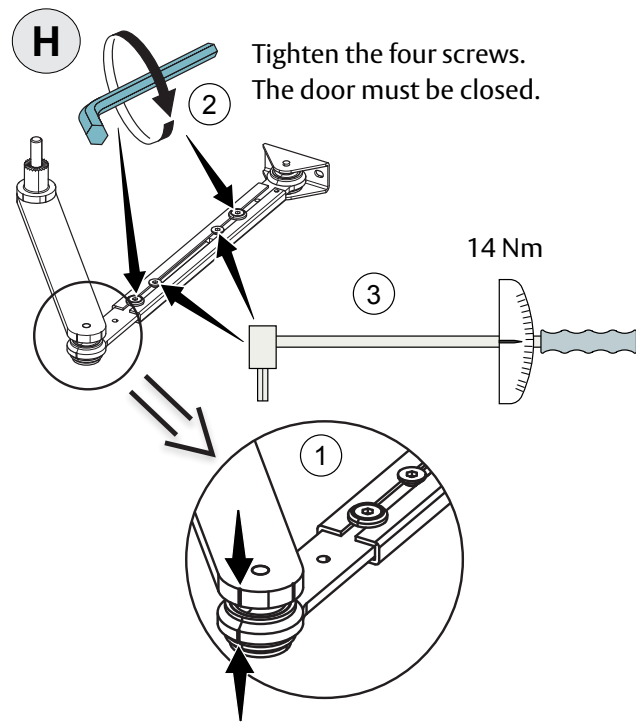

Make sure that the door opens to an angle of 95-110°. If necessary, adjust the door angle by moving the adaptor one step at a time before tightening.

12.5 INVERSE installation with PULL arm system

Remove the microswitch lever (1), but not the microswitch (2).

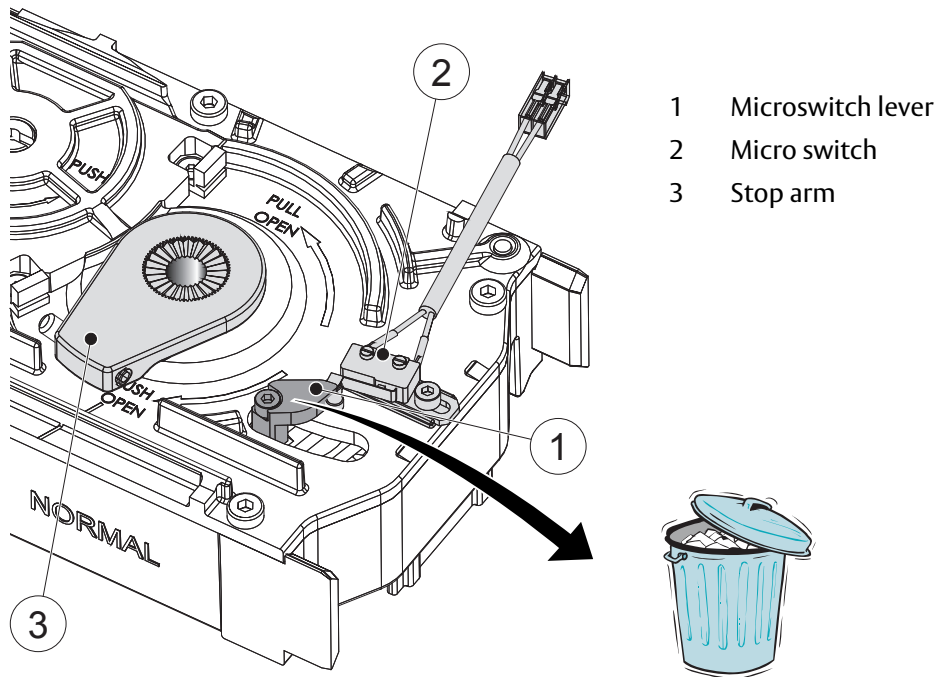

Note! Set dip switch INV to ON for INVERSE operation, see 13.1.1 on page 75.

For INVERSE installation (emergency opening function), maximum spring pre-tension is 7 mm or 14 mm measured between the washer and the hexagon nut. It needs to be adjusted so that the door opens and closes in a smooth way. The closing force needs to be measured and set with CLTQ to maximum 50%, to prevent motor overheating.

Note! Please pay attention to the different hexagon nuts for the measurement 7 mm or 14 mm.

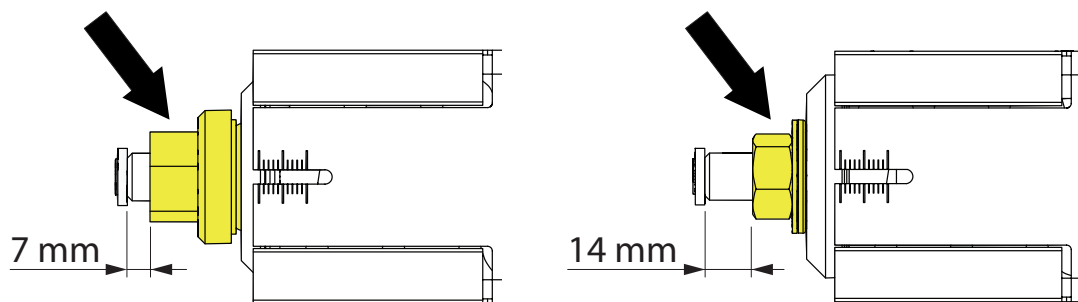

Follow below steps, note that the operator installation is same as for normal Push installations with the difference that the inverse text is visible on the drive unit when mounted correctly.

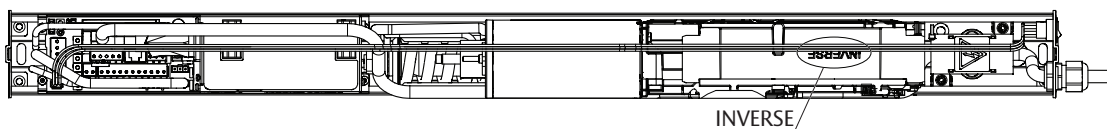

INVERSE operator with PULL arm system

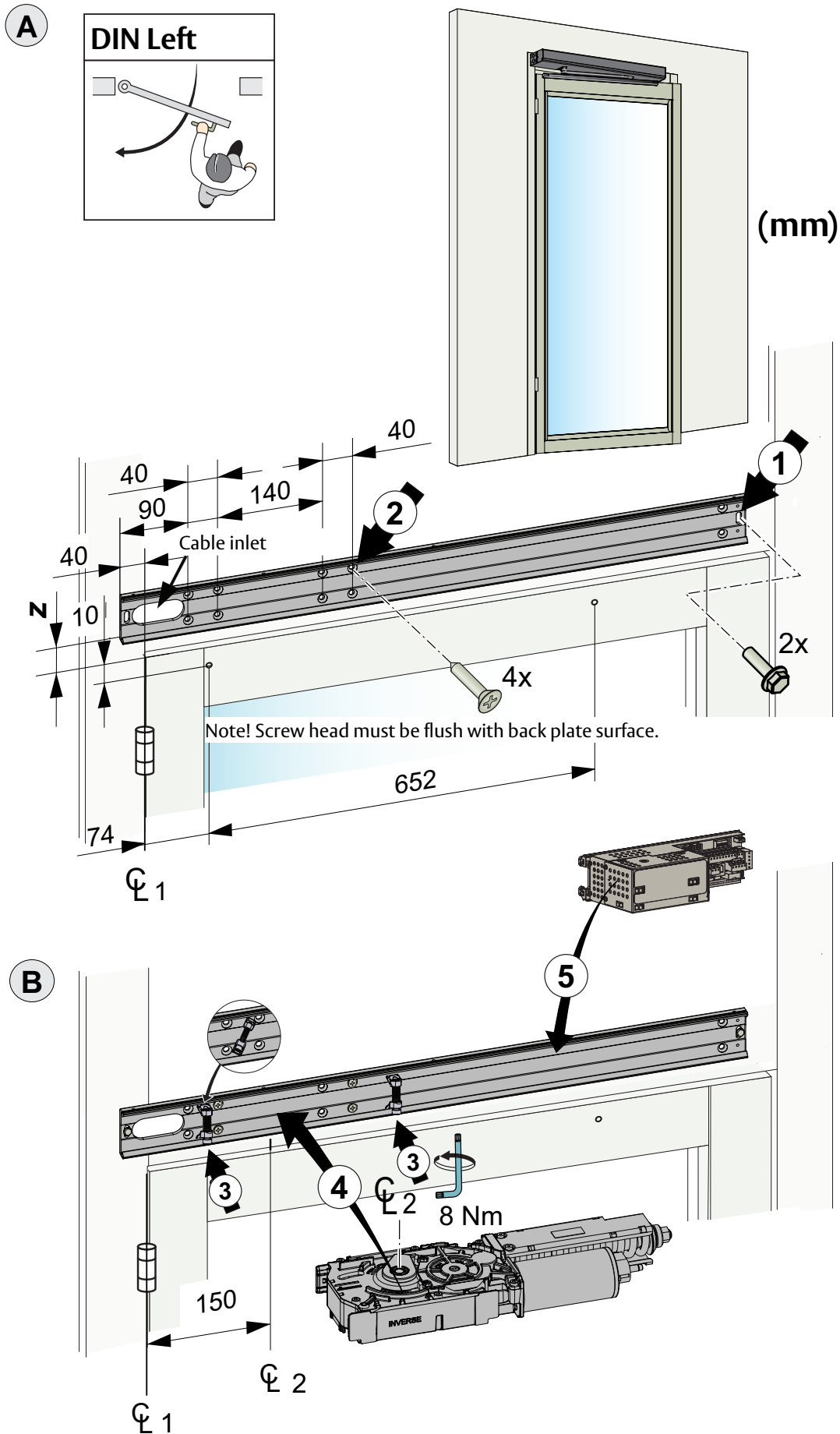

Continuous "Inverse operator with PULL arm system"

A

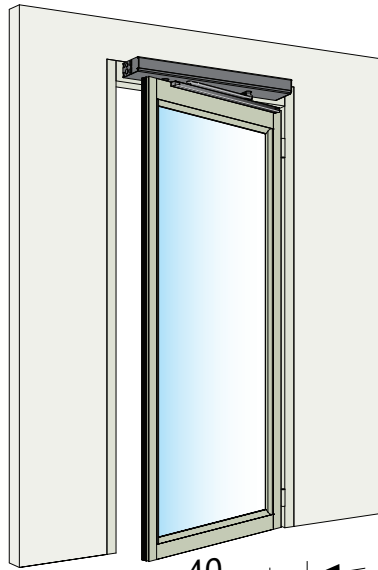
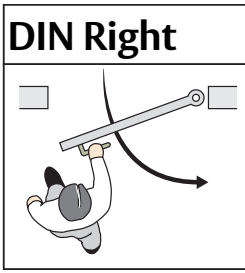

(mm)

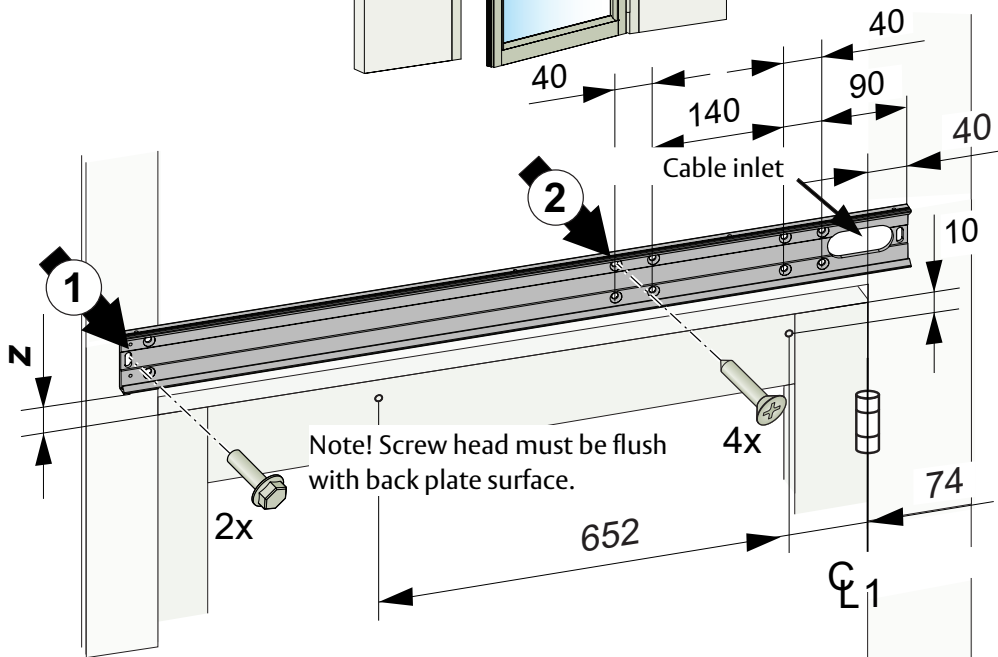

B

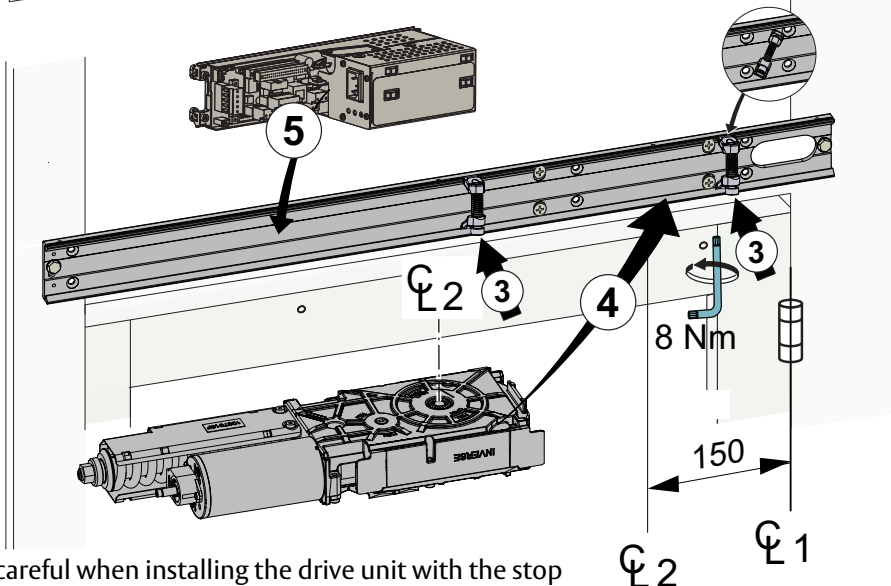

Note! Be careful when installing the drive unit with the stop arm underneath. There is a risk of the stop arm coming loose and falling.

Continuous "Inverse operator with PULL arm system"

C

DIN Right

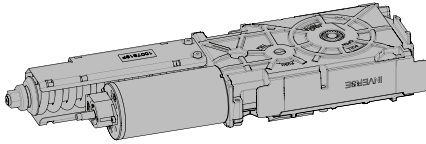

DIN Left

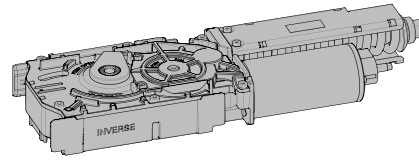

D

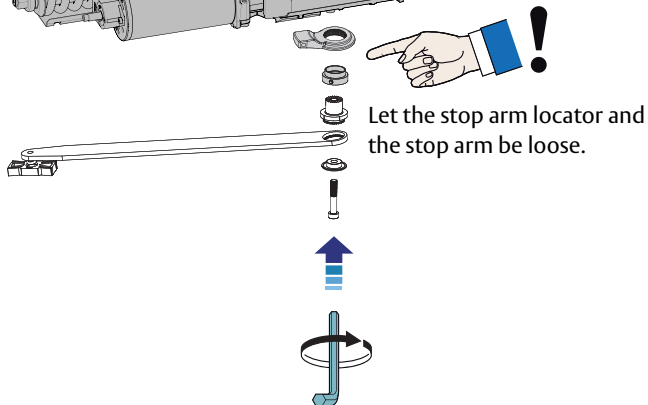
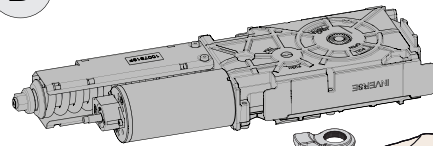

Do not tighten, splines should not be engaged.

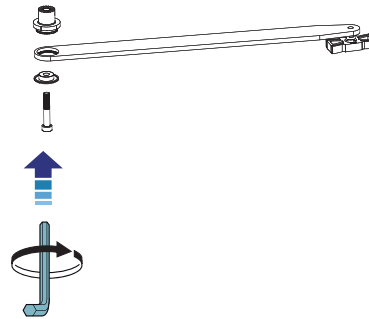
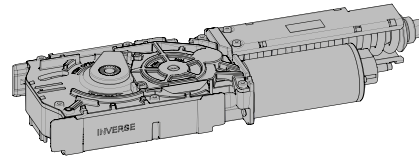

E

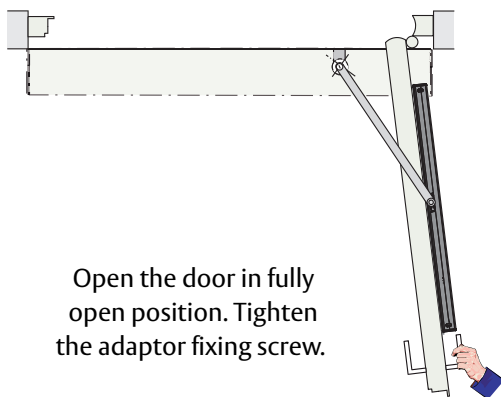

Open the door in fully open position. Tighten the adaptor fixing screw.

F

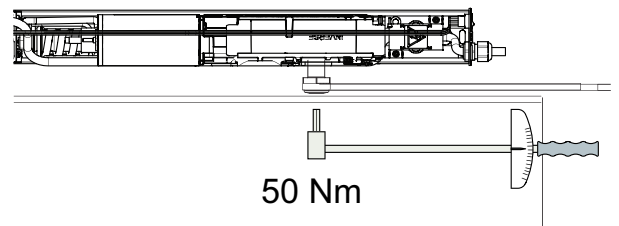

Make sure that the door opens to an angle of 95-110°. If necessary, adjust the door angle by moving the adaptor one step at a time before tightening.

12.6 Installation of COORDINATOR UNIT on rebating double door and Fire Door installations

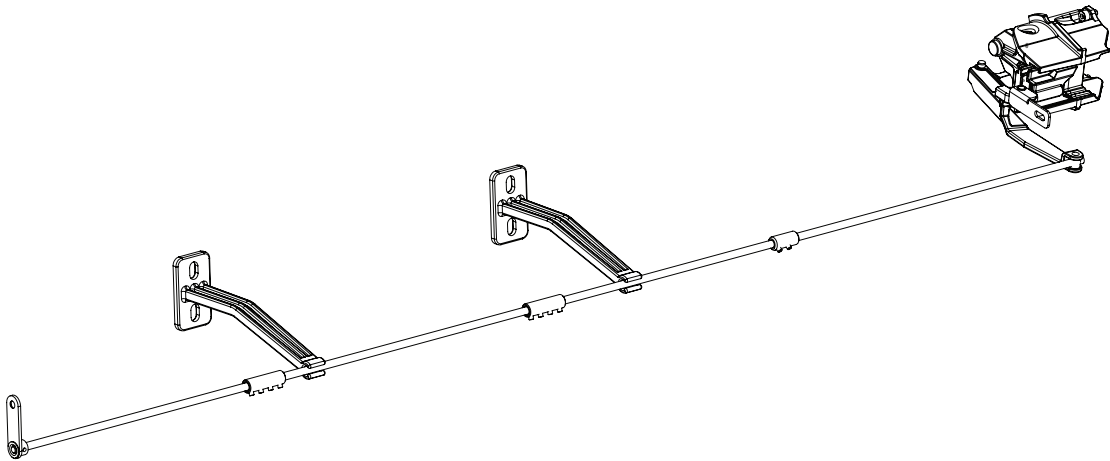

The mechanical coordination unit makes sure the secondary door closes before the primary door in a power-less state. The coordinator rod needs to be adjusted to stop the primary door before the latch check/lock-kick position.

Before installing the drive unit do step a-e below.

Screw in the two steering pins (1) for the coordinator base.

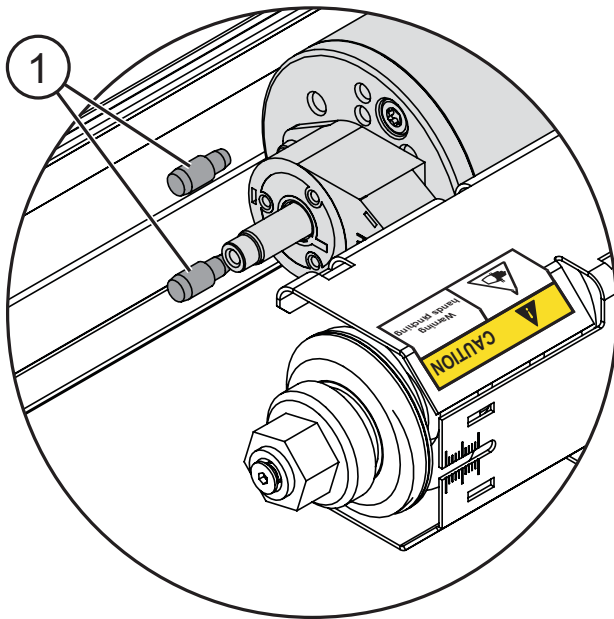

Mount the rotor (parts 2 to 4 below) before the motor is installed on the back plate. Install the control unit when the installation of the coordination unit is completed.

If the coordination unit will be installed on an existing installation it is possible to move the control unit a little bit to be able to reach the motor unit during installation.

Link rod length = hinge to hinge - 980 mm

- a Loosen the screws (2).

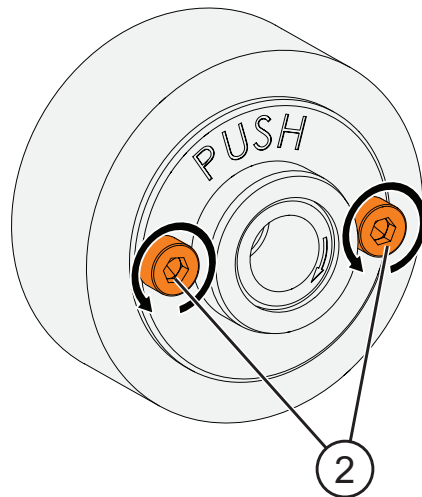

- b Take off the stop screws (17) in the joint (18) and use the stop screws (17) or other suitable tool to push the clutch cap (3) out of the rotor (4).

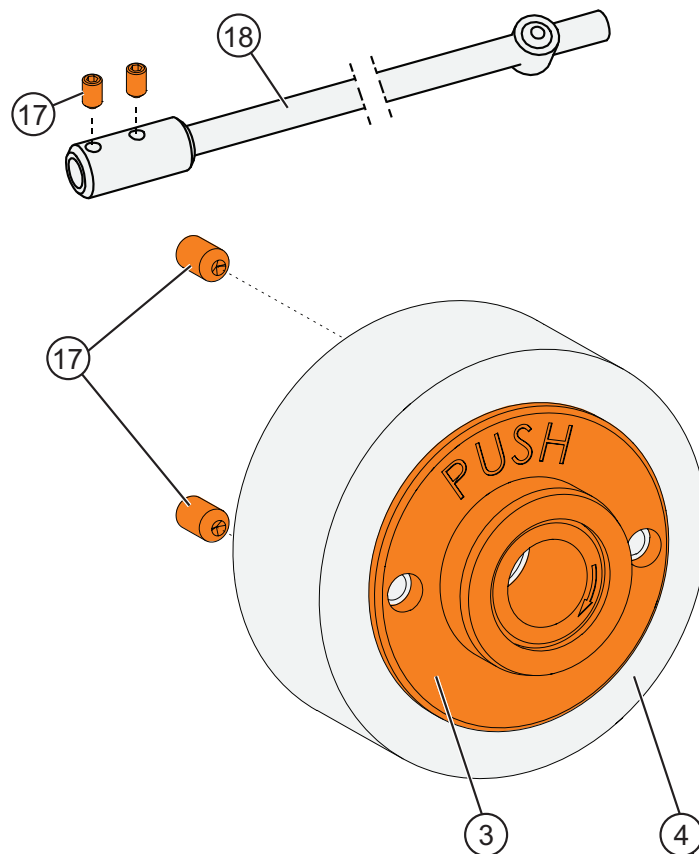

- c Turn the clutch cap (3) depending on PULL or PUSH installation. PULL visible for PULL installation and PUSH visible for PUSH installation.

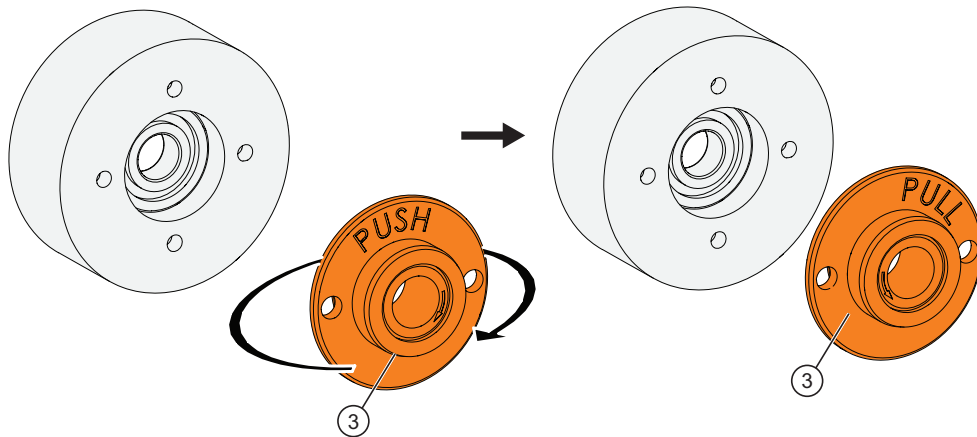

- d Tighten the screws (2).

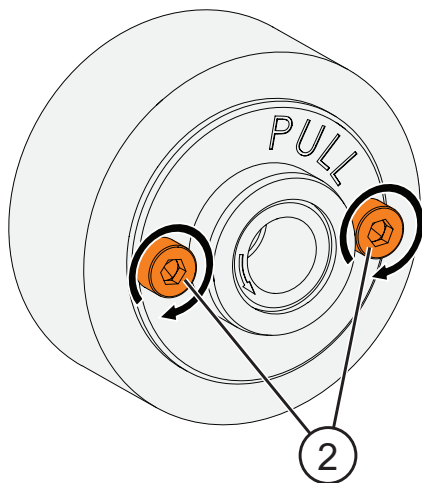

- e Install the rotor (4) on the motor unit (7) with the screw (5) and washer (6) on the primary drive unit = for the door that opens first and closes last.

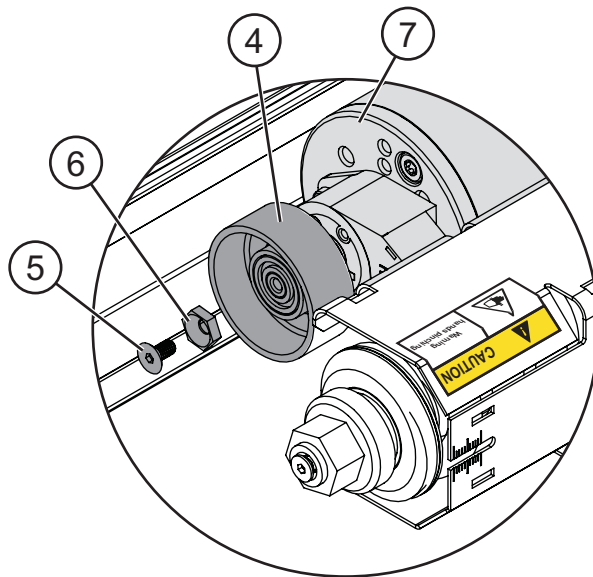

- f Release the brake (26) by pushing in the linkage arm (14), so that the brake (26) is opened, push the fork (27) into the coordinator base (15).

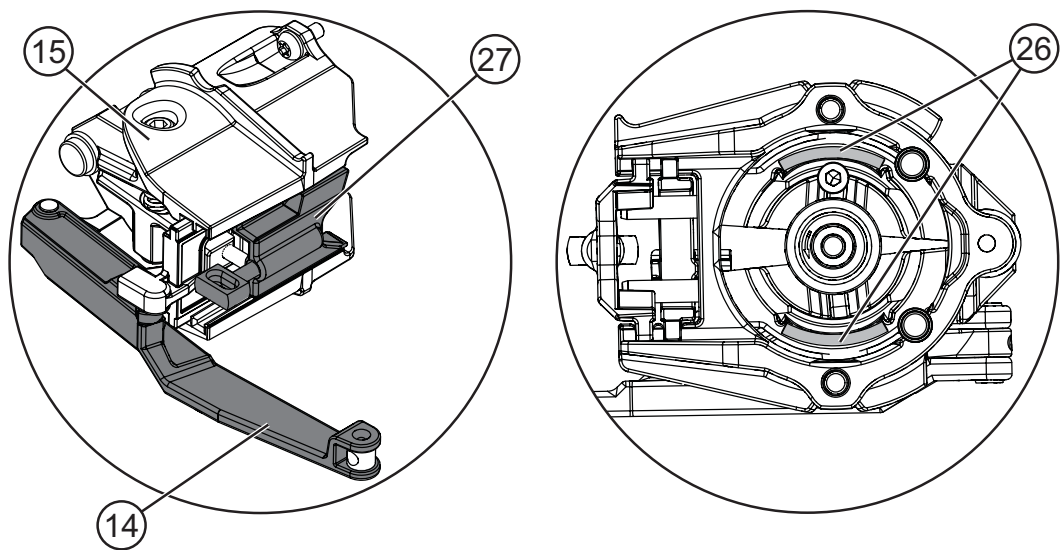

- g Install the coordinator base (15) with the two screws (8) on the primary drive unit. Remove the screw (9) and throw the washer (24) away when install the acceptor (11) on the adjuster (10). Install the screw (9) through the acceptor (11).
- h Install the transmission unit. Adjust the adjuster (10) by turning until the primary door stops at 15-18° from fully closed (this angle should be smaller than the electrical coordinator). Close the door by pressing the linkage arm (14).

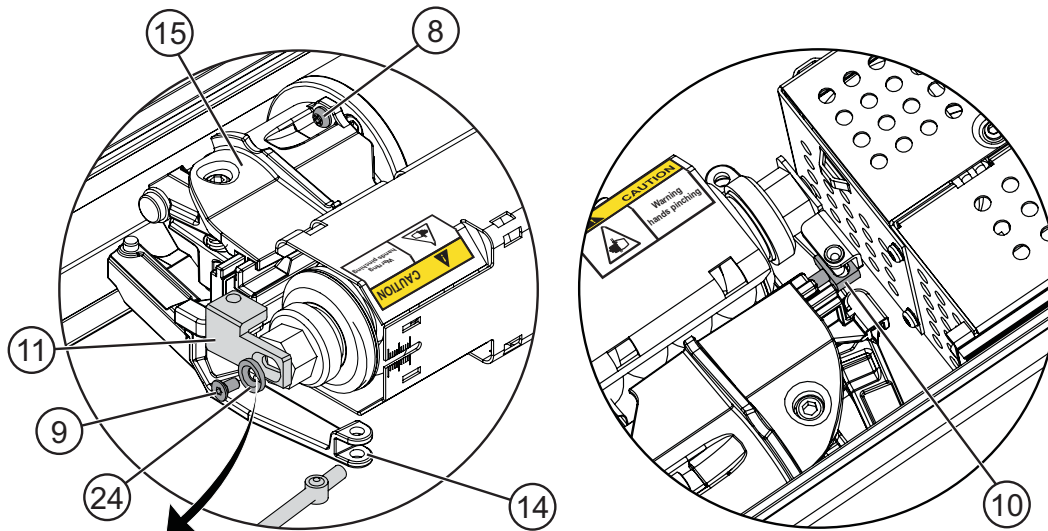

- i Adjust the braking torque to > 50 Nm measured on the door leaf by turning one or both screws (19).

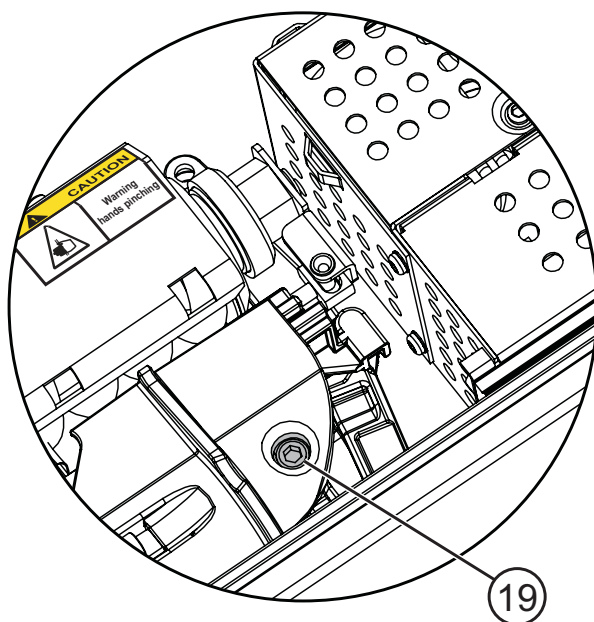

- j Install the link rod (12) with its adaptor (13) into the linkage arm (14).

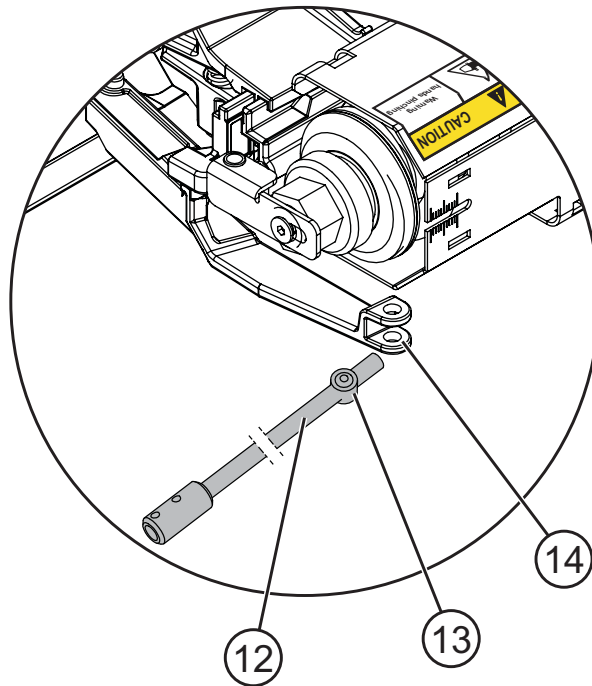

- k Install on the other side of the link rod (12) to the secondary motor unit with the signal (16). Fasten the stop screw (17) with a torque of 80 Ncm.

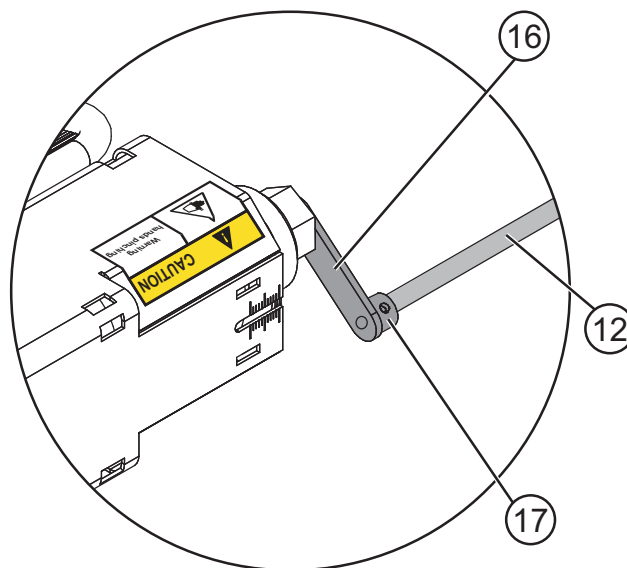

- l Adjust the release of the brake by loosening the joint (18) and turning the link rod (12) close to the primary drive unit. Make the angle between the doors near closed position. Tighten the stop screws (17) to 80 Ncm.

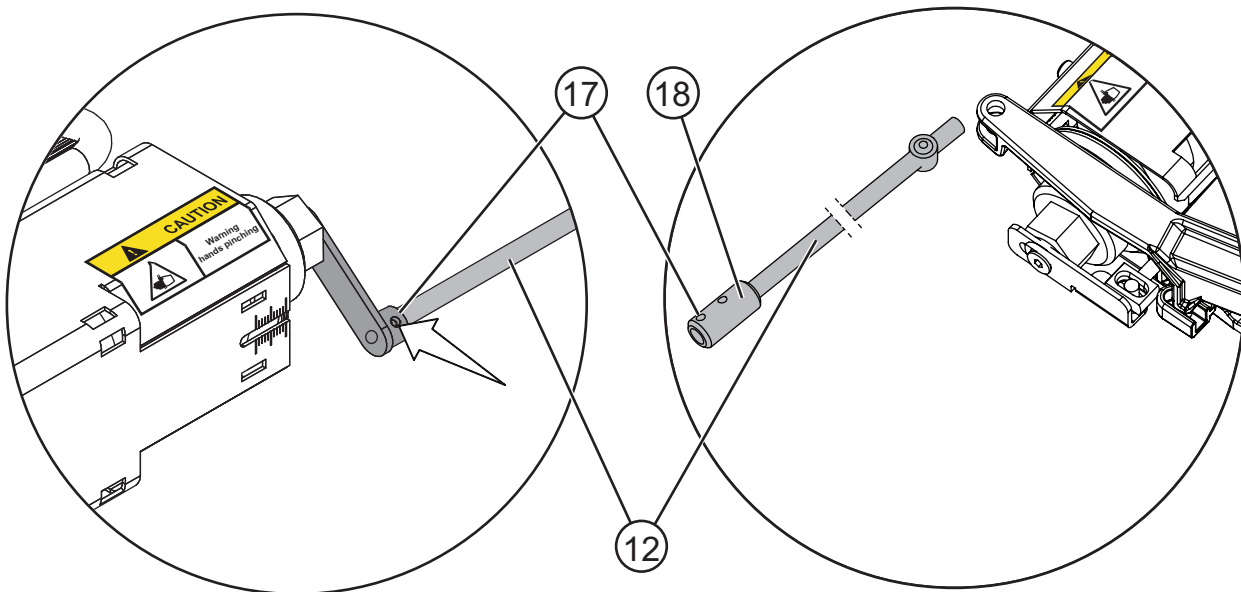

- m Route the cables, see illustrations on page 42.
n Put the grease on the rod support.

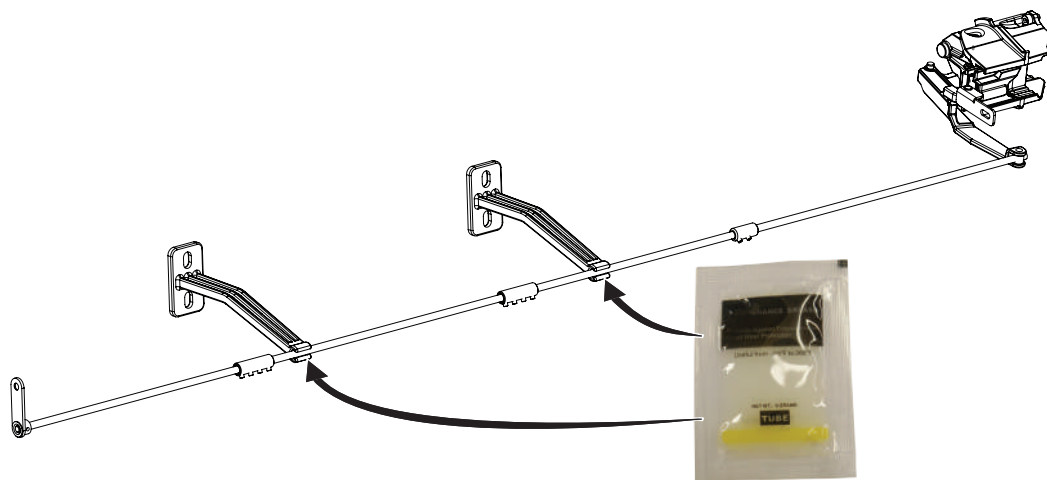

- o Install the follower roller (20) at the leading edge close to the top of the secondary door leaf (21) with the appropriate screws (23).

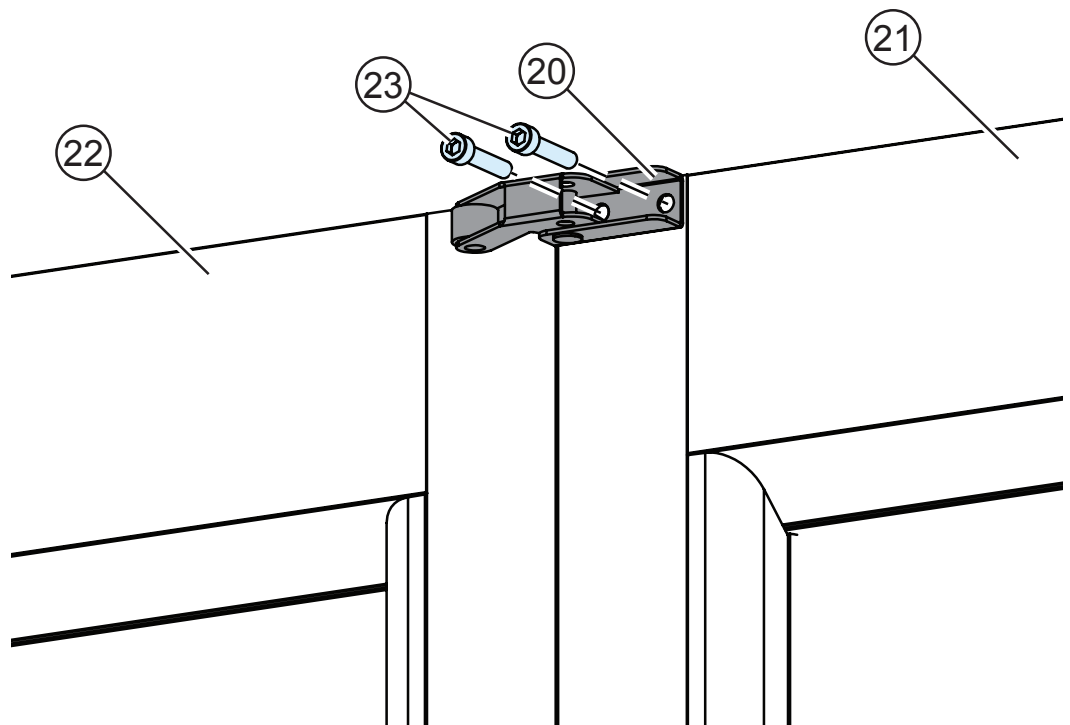

13 Electrical connection



During any work with the electrical connections the **mains** must be disconnected.

- Place the electric switch easily accessible from the operator. If a plug contact is used in the installation the wall socket shall be placed easily accessible from the operator.
- If the supply cord is damaged, it must be replaced by the manufacturer, its service agent or similarly qualified persons in order to avoid a hazard.

[See Auto-learn-automatically sets back and latch check \(recommended\) on page 87.](#)

Mains connection

Note! Switch shall be installed in a way so that it will not be reactivated by mistake.

- a Switch off the mains.
- b Connect the plug contact to the wall socket or connect to the mains switch.

Standard

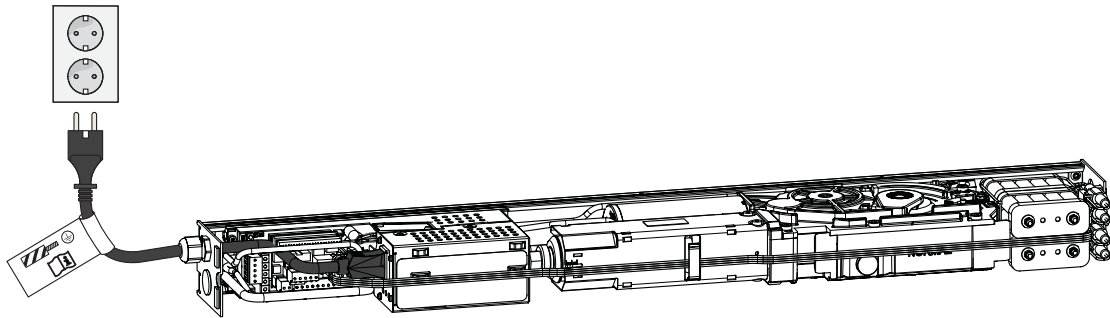

13.1 Control units

13.1.1 CUS7 (DAB305CU)

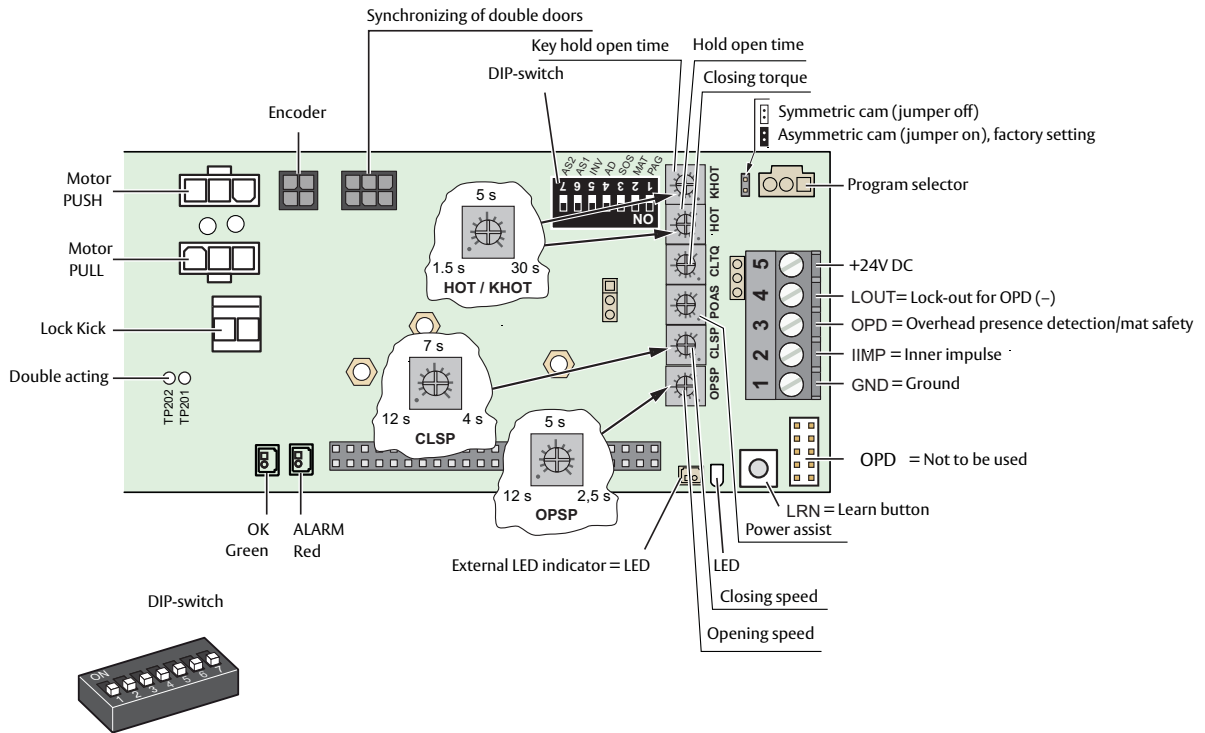

- 1 PAG = Push & Go
- 2 MAT = Safety mat
- 3 SOS = Stop on stall
- 4 AD = Activation delay
- 5 INV = Inverse installation
- 6 AS1 = Arm system setting
- 7 AS2 = Arm system setting

Note! Connect the motor cable to either PUSH or PULL depending on arm system.

13.1.2 Arm system selection

Factory set arm configuration is PUSH, if other is required:

Select arm configuration on the DIP-switches according to the table below.

Type of arm system	ON=1 OFF=0	
	AS 1 DIP 6	AS 2 DIP 7
PUSH	0	0
PULL	1	0
DAB805PLA5 (narrow door)	0	1
Sliding PUSH DAB805PL3	1	1
Sliding PUSH DAB805PL4	0	0

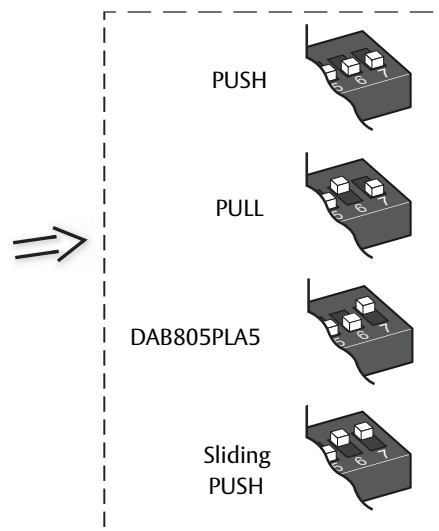

Note! After changing any system selection a new LEARN must be carried out.

13.1.3 Extension units DAB905ESE / DAB905ESA

Installation

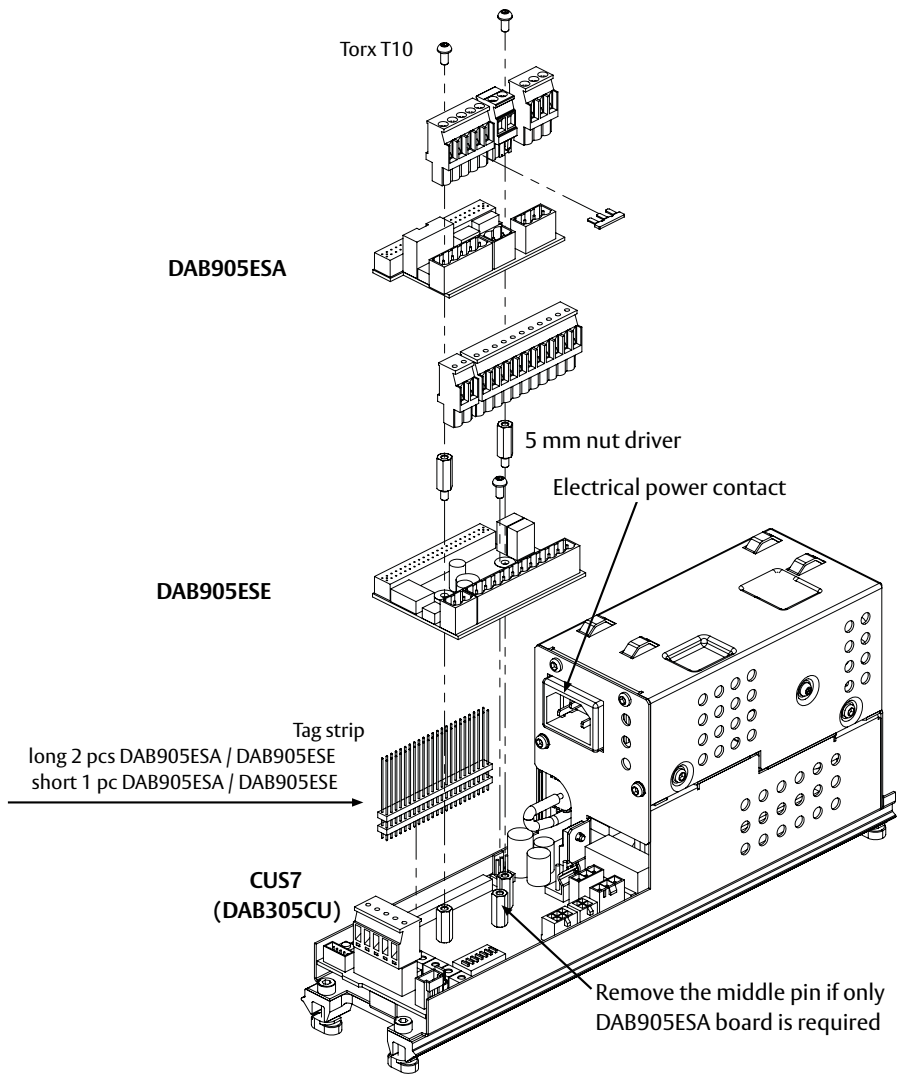

13.1.4 Extension unit DAB905ESE

This extension unit has inputs for electro-mechanical lock, program selector, batteries, KILL function, OPEN/CLOSE, KEY opening and outer impulse.

Functions

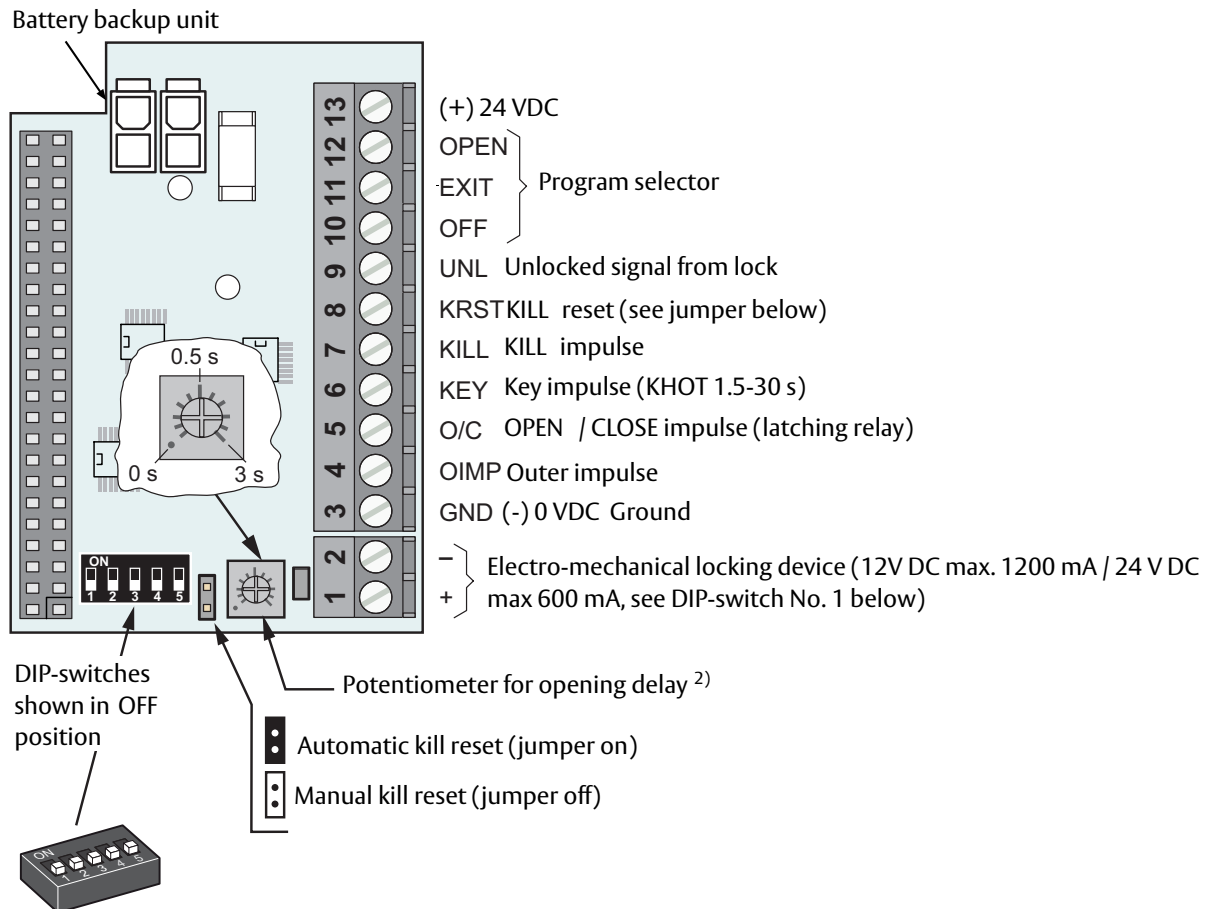

- 1 Lock 12 V (OFF) / 24 V (ON)*
- 2 Locked without power (OFF) / with power (ON)*
- 3 Lock release*²⁾
- 4 Lock kick¹⁾
- 5 Battery monitoring

1) Position OFF: Smooth closing, to be used on doors without lock.
 Position ON: More powerful closing, to be used on doors with lock, to overcome binding in the locking device (inactivated for Inverse door).

2) If the switch is set to ON, the LOCK RELEASE is active during the opening delay time set by the potentiometer.
 For PAIR OF DOORS installations, the LOCK RELEASE works in sequence: First the primary door then the secondary door.

Note! Lock only functions when Program Selector is in OFF or EXIT.

Lock Pin 2 (-) may only be connected to a lock. For sensors or other peripherals, use Pin 3 (GND).

* After changing dip settings, a new LEARN must be carried out.
 With selection 'Locked without power' is the lock energized from 0 to 10 degrees at opening.
 If a program selector is not used, a jumper is required from position 3 to position 11.

13.1.5 Extension unit DAB905ESA

This extension unit has inputs for door mounted sensors, which can give presence impulse on approach side and/or presence detection on swing path side. Relay output for error indication or door indication is also integrated. When the jumper for the relay is set to 'Open door indication', its activation will follow the Blanking LED. To enable sensor monitoring, remove corresponding jumpers DMPS.SS and DMPS.NS on DAB905ESA board.

Functions

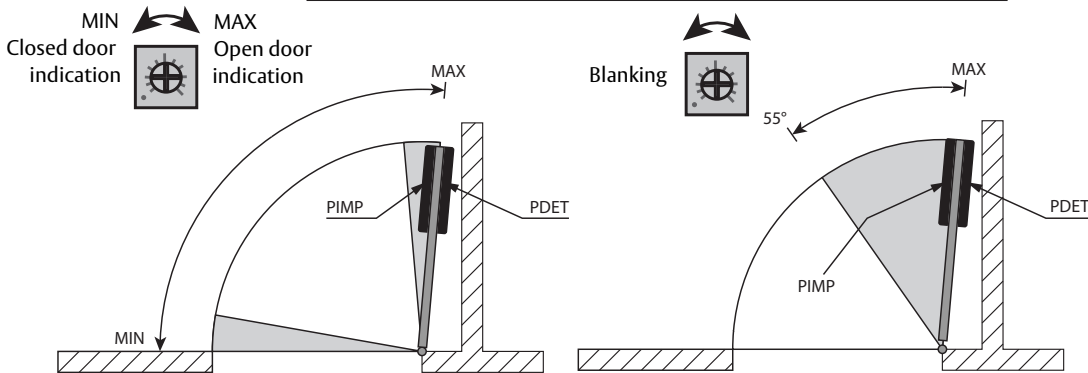
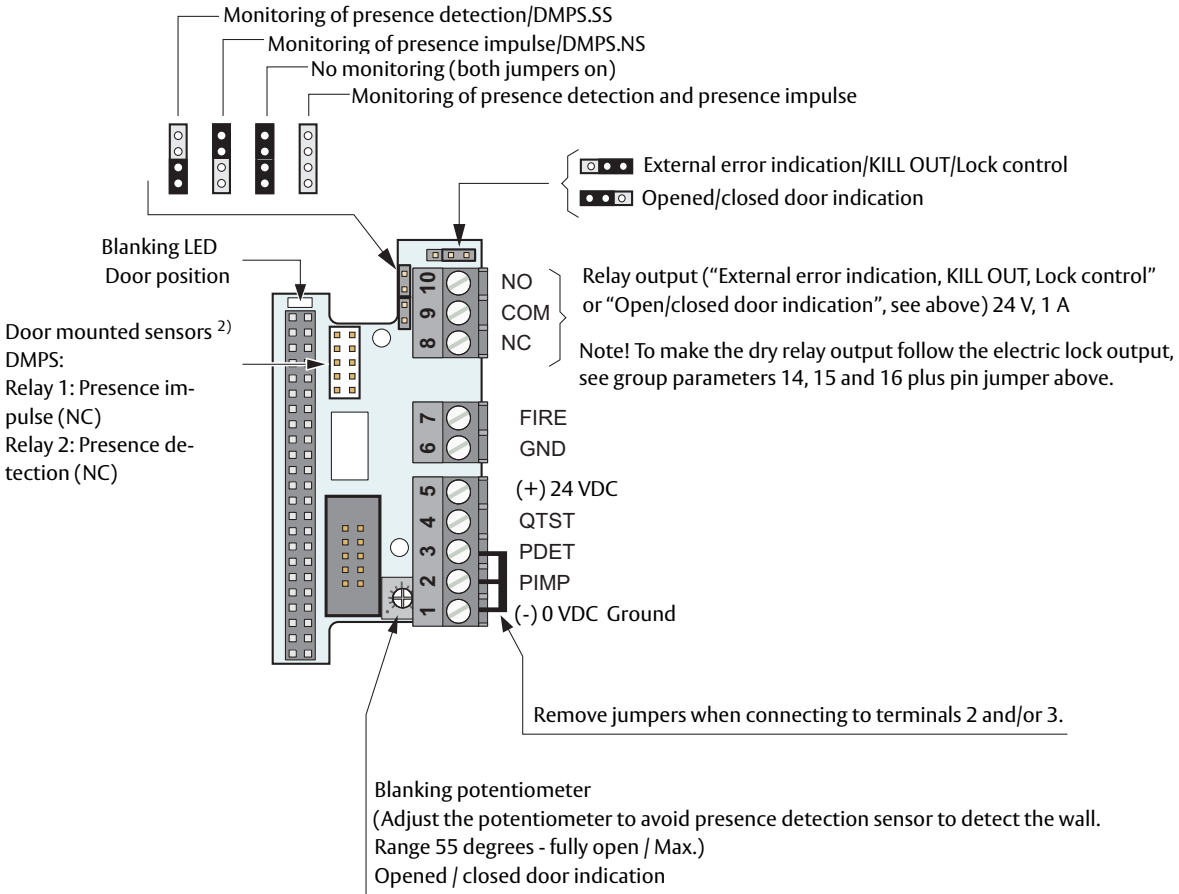

QTST = Sensor monitoring and reference for KILL (NC)

PDET = Presence detection (NC)¹⁾

PIMP = Presence impulse (NC)¹⁾

1) If not used jumper to "Ground".

2) Remove jumpers from terminals 2 and/or 3.

13.1.6 Installation on double doors

If the operators are to be mounted at the same height with pushing and pulling arm systems, the height is determined by the pulling arm system, PULL. The pushing arm system PUSH must always have a shaft extension, minimum 50 mm, maximum 70 mm to match the mounting heights visually.

Example: if PULL has a 20 mm extension, the PUSH must have a 70 mm extension. If PULL has 0 mm extension, the PUSH must have a 50 mm extension.

For installation, follow the instructions for the applicable arm system. If using a closing coordinator, see page 66 a-e before starting the installation.

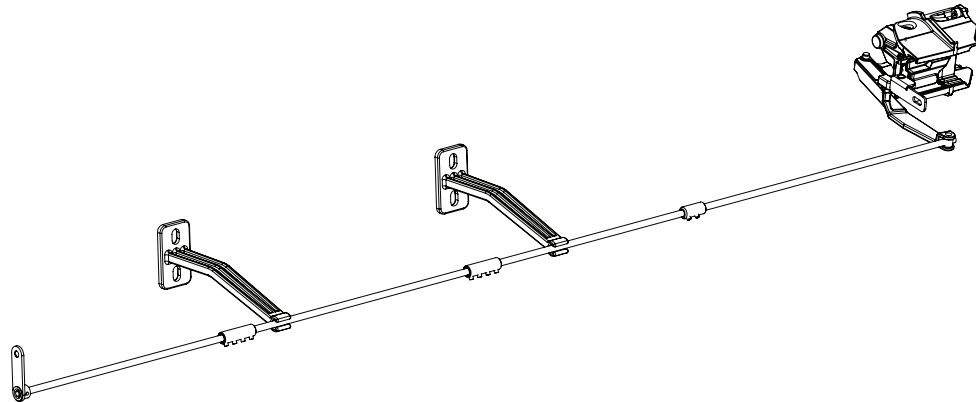

13.2 How to cut the jumper on the sync cable for double doors

Note! Connect a cable between primary CU and secondary CU.

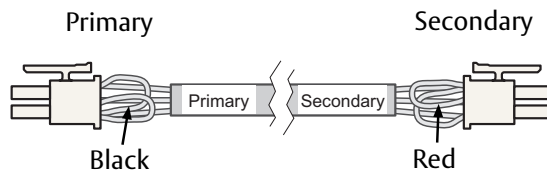

Note! The connection/marking of the sync cable determines which of the operators is the primary and secondary.

For a Rebated door

- the **Primary door** must **open** before the **secondary door**
- the **secondary door** must **close** before the **Primary door**

Function		Door design		Cut the jumper with color	
Opening	Closing	Rebated	Jamming	Primary side	Secondary side
Synchronous	Synchronous	No	No	No cutting	No cutting
Synchronous	Asynchronous	Yes	No	Cut black	No cutting
Asynchronous	Asynchronous	Yes	Yes	No cutting	Cut red
Double egress		—	—	Cut black	Cut red

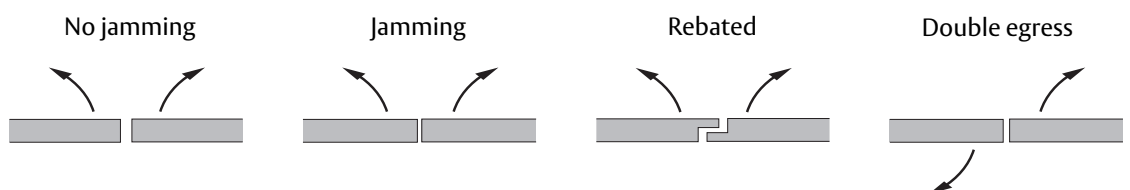

13.3 Double door installations

There are four different types of double door installations:

- Rebated – Has an overlapping primary door, can be opened synchronously if it is not jamming and must be closed asynchronously to avoid that the doors will jam or close in the wrong order.
- Jamming – This door type needs to be opened and closed asynchronously to avoid that the doors will jam with each other.
- Not jamming, not rebated – This door type has doors that always can move independently of each other and can be opened and closed synchronously.
- Double egress – This door type has doors that opens in different directions which can be opened and closed independently. This door type may have a different way of handling safety sensors due to the difference in opening direction of the doors.

13.4 Settings for double doors

Function	Settings on the	
	Primary	Secondary
Common		
Program selection	X*	
Opening time	X	
Closing time	X	
Hold open time	X	
Close / Continue to open when the door is obstructed	X	
PAG On/Off	X	
SOS On/Off	X	
Level of Power assist	X	(X)**
Extended closing torque	X	(X)**
OPD/OPS Impulse or Mat Logic Impulse	X	
Selection of operating mode during operation on battery power	X	
Individual		
Lock/Unlock signal voltage	X	X
Locked without/with power	X	X
Lock release Enable/Disable	X	X
Open Delay Time	X	X
Lock kick Enable/Disable	X	X

* Program selectors in a double door must be connected to the primary operator, connection to the secondary operator will not be valid.

** For “Double egress doors”, these functions must be set separately for primary and secondary as the arm systems as well as the air pressure may be different.

Note!

- Locks on the primary and secondary doors must be connected to the control unit (CU) on the corresponding operator.
- Inner and outer impulses can be connected to either primary or secondary CU or both.
- The OPD/OPS is to be connected to the primary CU except for “Double egress”, where each OPD/OPS must be connected to corresponding CU.
- Door leaf mounted sensors must always be connected to corresponding CU.

13.5 Sensor cable inlet

Art. No.: DAB805SCI

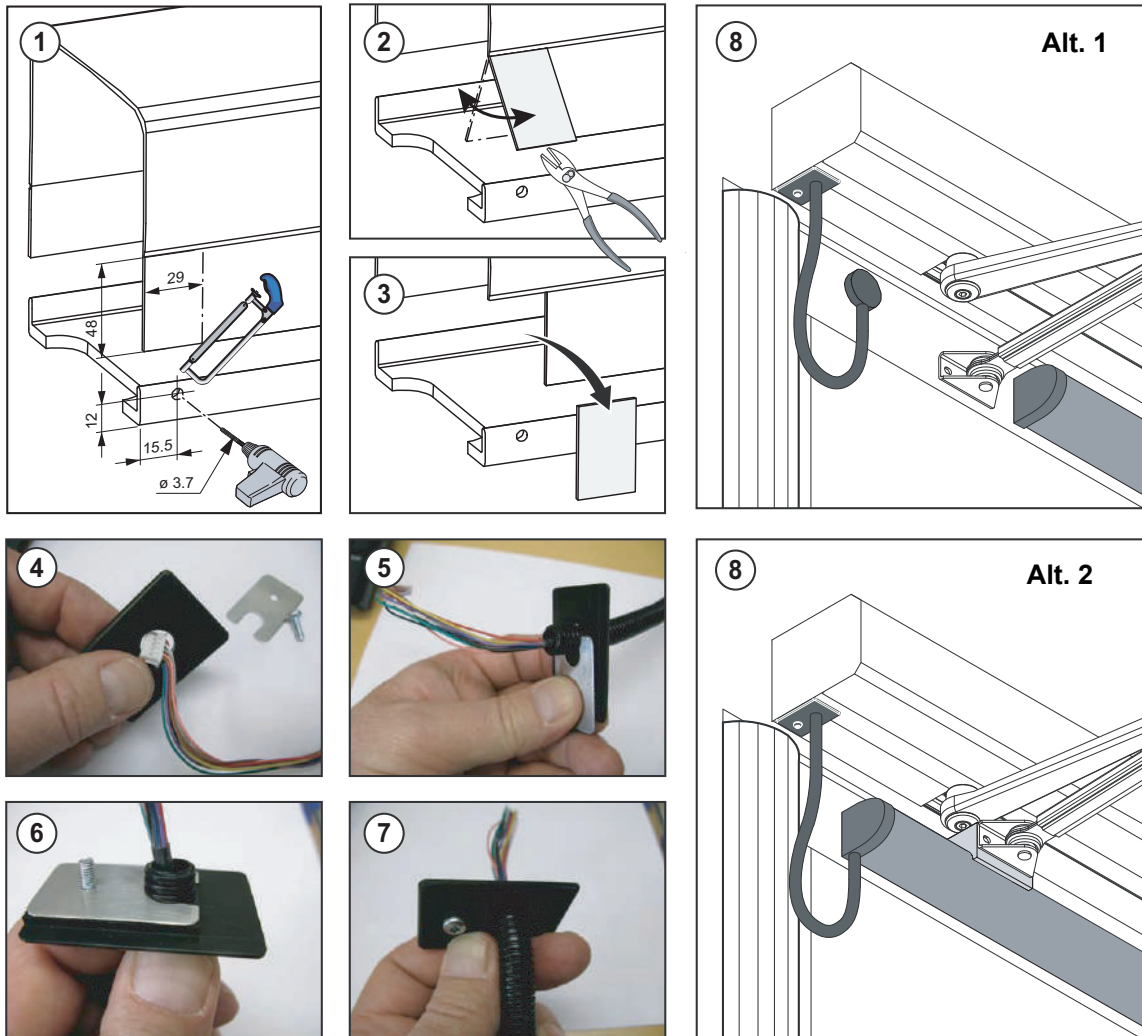

13.6 Reset and indication device for Fire Doors

Art. No.: DB905RSD

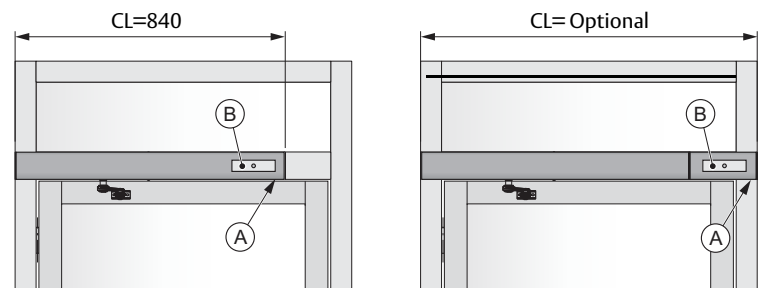

(A) Reset & Indication device
 (B) Smoke detector

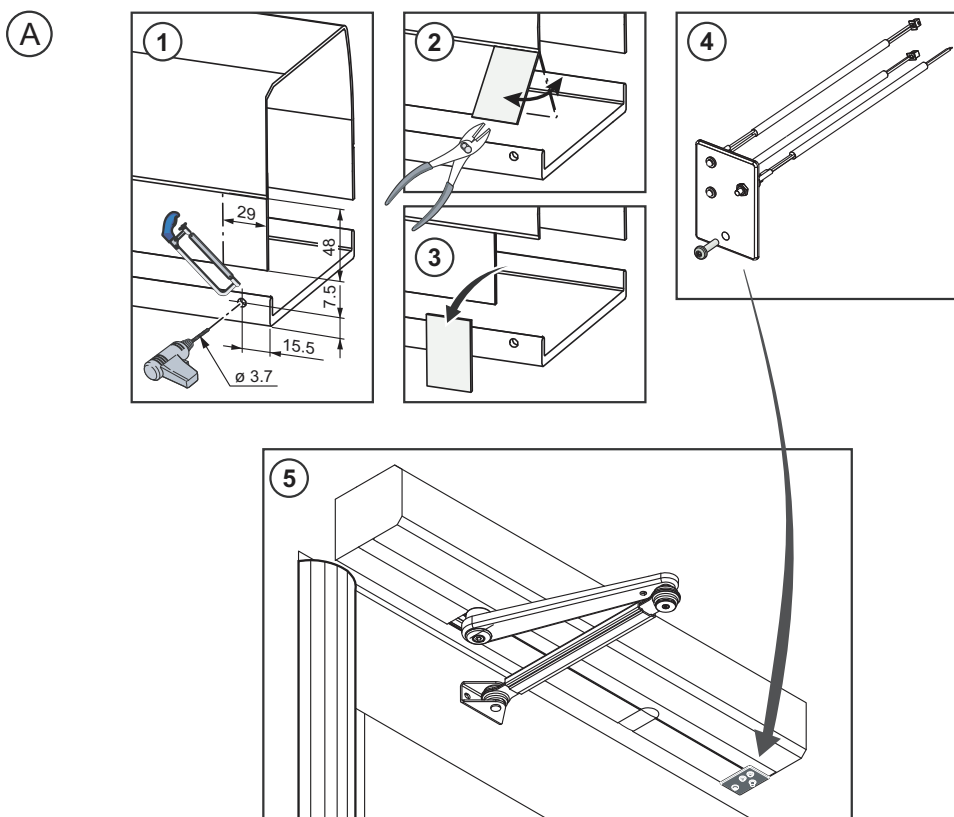
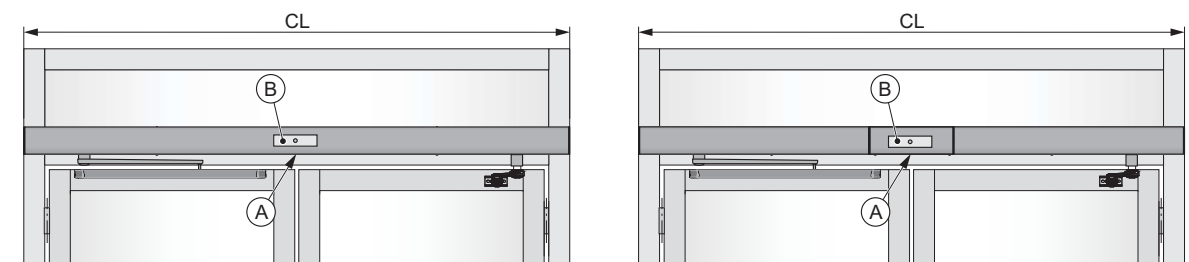

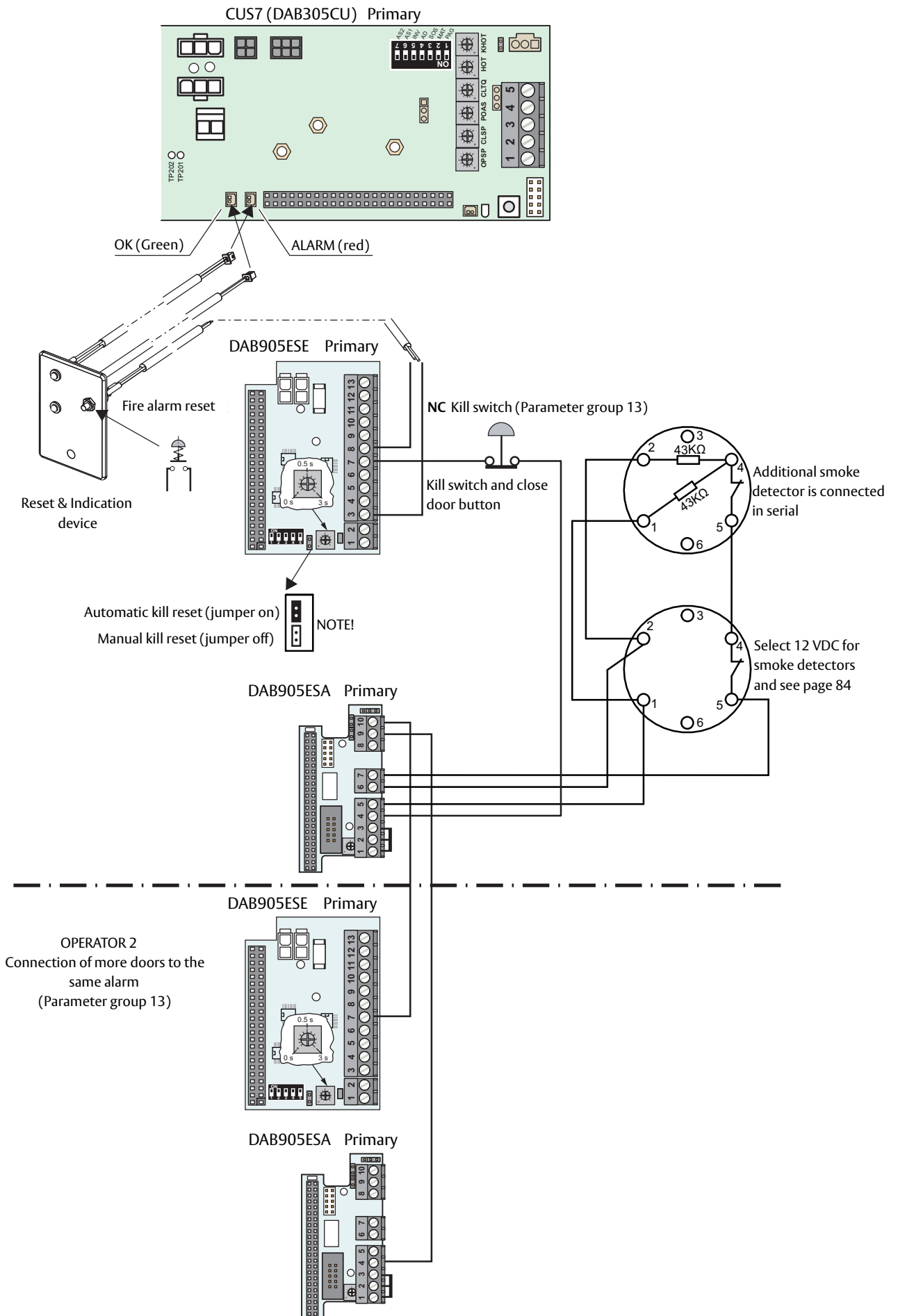

14 Start-up

14.1 Spring pre-tension

The spring pre-tension is **factory set to EN4**. The closing torque (spring force in power off) is adjusted by a hexagon nut placed at the end of the spring. Turning the nut clockwise increases the force. One turn equals a torque change of approximate 7 to 9 Nm for PUSH and 4 to 6 Nm for PULL (approximate 7 turns from minimum to maximum).

* **Inverse only:** For Inverse installation (emergency opening function) maximum spring pre-tension is 7 mm or 14 mm measured between the washer and hexagon nut and needs to be adjusted so that the door opens and closes in a smooth way. The closing force is to be measured at point (P) and set with CLTQ to maximum 50%, to prevent motor overheating.

Note! Please pay attention to the different hexagon nuts for the measurement 7 mm or 14 mm.

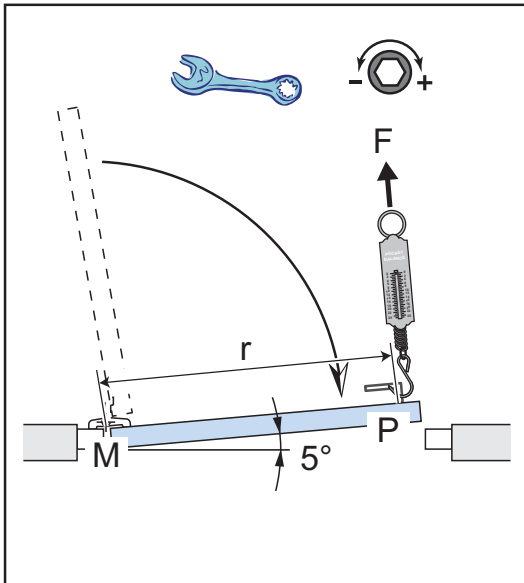
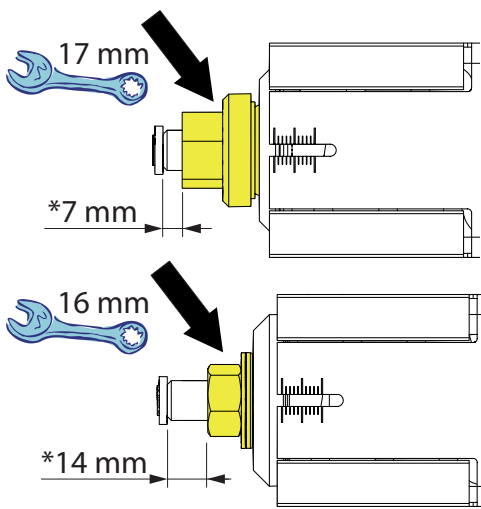

Door closer power size according to EN1154	Recommended door leaf width mm max.	Closing torque between 0° and 4°		Opening torque between 0° and 60°
		Nm (minimum)	Nm (maximum <)	Nm (maximum**)
4	1100	26	37	62
5	1250	37	54	83
6	1400	54	87	134
7	1600	87	140	215

Measured with spring balance at point (P) 10 N ≈ 1 kg		
Distance (r) from hinge to measuring point P	Closing force (F) between 0° and 4° measured at point P	
	N min.	N max. <
1050	25	35
1200	31	45
1350	40	64
1550	56	90

Formula: $M = r \times F$

Example: You have an EN 5 door. Your door is 1200mm and your point of measuring (P) is at (r) 1.15m. Maximum closing torque between 0° and 4° is (M) 54Nm taken from table above in red.

Calculate (F) for your door:

Find (F) for your door:

Find (F) in measuring point (P) = M/r

$54Nm / 1.15m = 47N$

Your maximum closing force at your measuring point (P) is 47N.

** **Note!** Maximum opening force in escape route is 150 N.

14.2 Micro switch

Check and adjust the micro switch, controlling the lock kick at power failure. Make sure to connect the micro switch on the control unit to avoid that the door slams close uncontrolled during power failure. If no lock kick during power failure is mandatory (e.g. fire doors) make a NC connection on the socket of the micro switch.

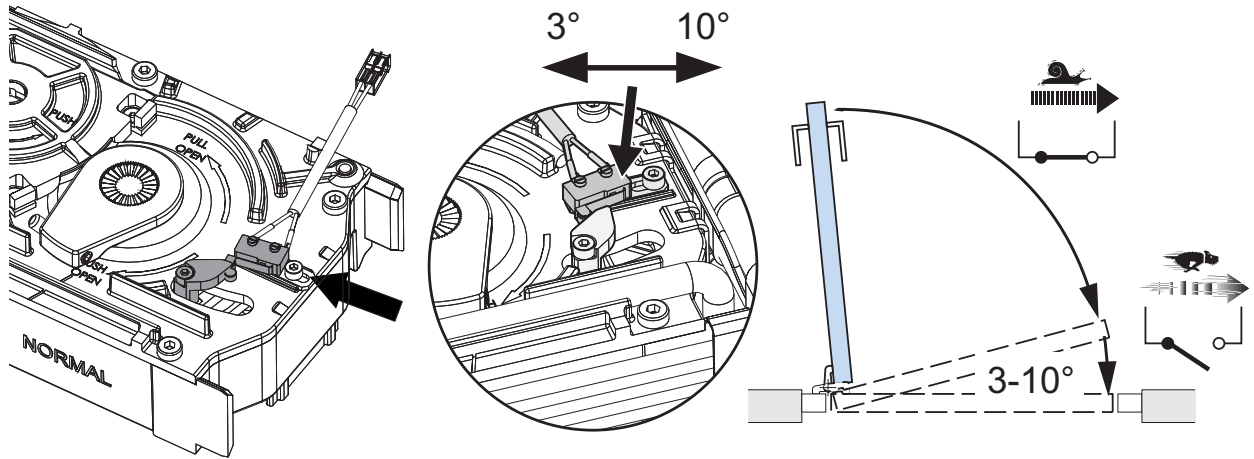

14.3 Adjusting the door stop

- a Close the door.



- b Open the door to required open position, plus approximate 15 mm. Put a doorbuffer under the door.

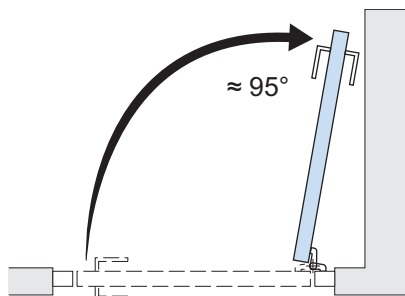

- c When stop arm is on top of the operator, lift the door stop arm up and mount it on the splines, as close as possible to the stop block 1). Fine-adjust if necessary with the screw on the stop arm 2).

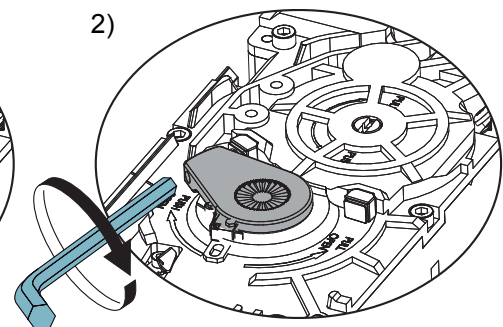
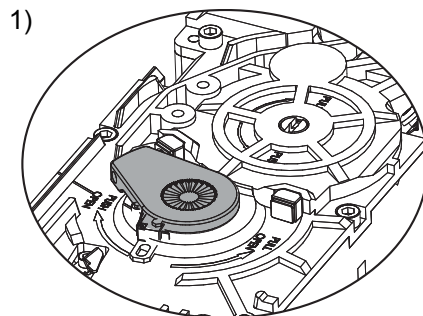

- d When stop arm is on the bottom of the operator, loose the stop arm locator and the stop arm. Mount the stop arm on the splines, as close as possible to the stop block 3). Mount the stop arm locator. Fine-adjust if necessary with the screw on the stop arm 4).

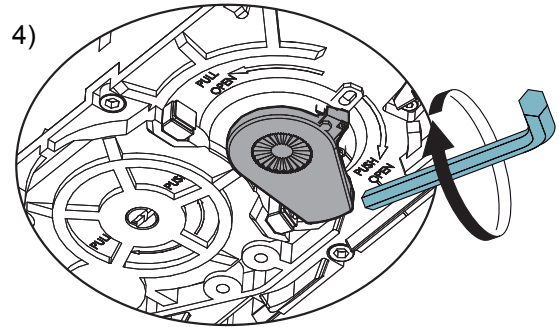
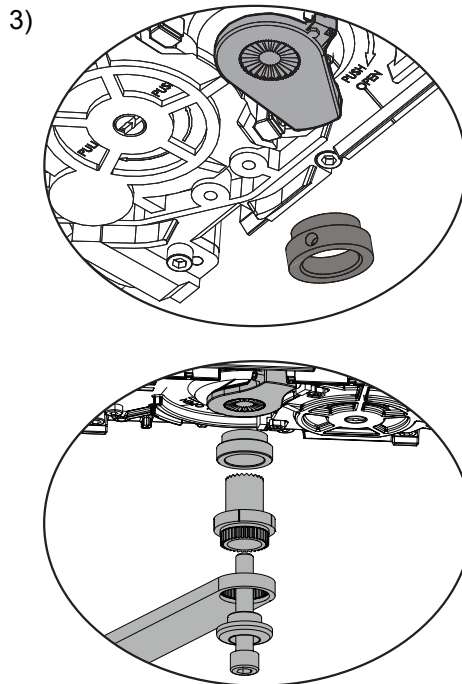

Note! Be careful when installing the drive unit with the stop arm underneath. There is a risk of the unit coming loose and falling

- e Close the door.

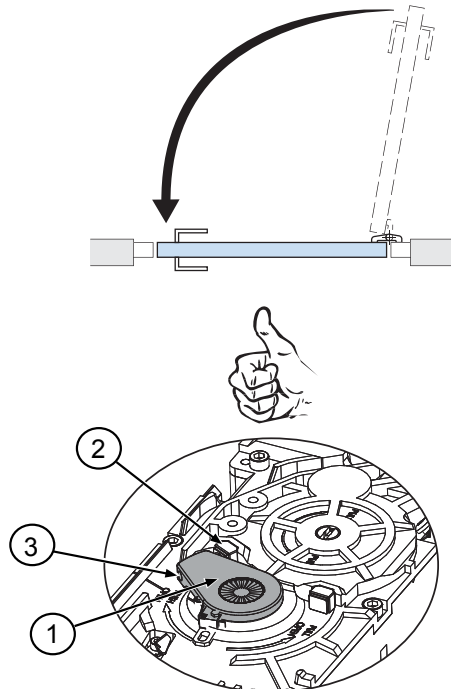

- 1 Stop arm
- 2 Stop block
- 3 Fine-adjustment screw

14.4 Auto-learn-automatically sets back and latch check (recommended)

This learning is performed by pushing the LEARN BUTTON (LRN).

- Switch on the electrical power (the operator will find its closed position) and make sure the LED is on.

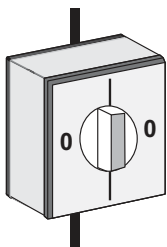

- Before the learning procedure starts, make sure that the door has been properly closed i.e., not by force.
- A new learn must be carried out in following situations
 - If any of the parameters SPRING PRE-TENSION and CLOSING TORQUE (CLTQ) are changed after performing a learn.
 - If any of the arm system DIP-switches are changed.
- A confirmation by pushing the learn button is enough in following situations
 - If any changing of the MAT-DIP switch.
 - When replacing any of the extension units.
 - When changing of Locked with/without power.
 - When changing of Lock 12/24 V.
- Learn can be carried out with activation units and locks connected.
- The back-check will be automatically adjusted to 10° and 1 second before open position. The latch-check will be automatically adjusted to 10° and 1.5 seconds before closed position.

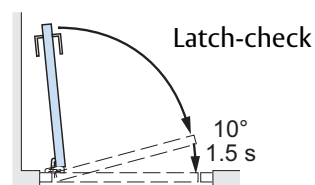
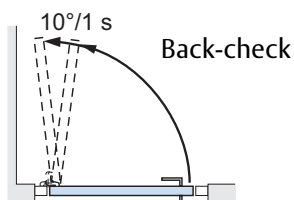

14.4.1 Push the LEARN BUTTON (LRN)



The door has no safety during auto-learn cycle. Remain clear of swing path of door, as door may close rapidly.

Note! If the learn button is just pushed once, a learn for reveal 0-100 mm will be carried out. For greater reveal, press and hold the button, and release it when the status LED is blinking for desired reveal, see below table.

LED flash frequency	Reveal [mm]	Available for arm systems
One 0.3 s flash, 2 s pause	0 - 100	PUSH, PULL, Sliding PUSH
Two 0.3 s flash, 2 s pause	101 - 200	PUSH, PULL
Three 0.3 s flash, 2 s pause	201 -	PUSH, DAB805PLA4

When the learn button is pressed the status LED starts to blink and will not stop until learn is concluded.

Note! If no floor door stop is mounted, stop the door in required opening position.

The learn cycle starts with sensor detection, during which the door will stand still. When the door starts moving the spring tension and door inertia are measured and the door open and close position is saved. When the learn is concluded the back-check, latch-check, opening time and closing time are calculated. The changed settings affect the behavior of the installation and must be verified. Refer to page 100 for adjusting opening and closing time in the low energy mode.

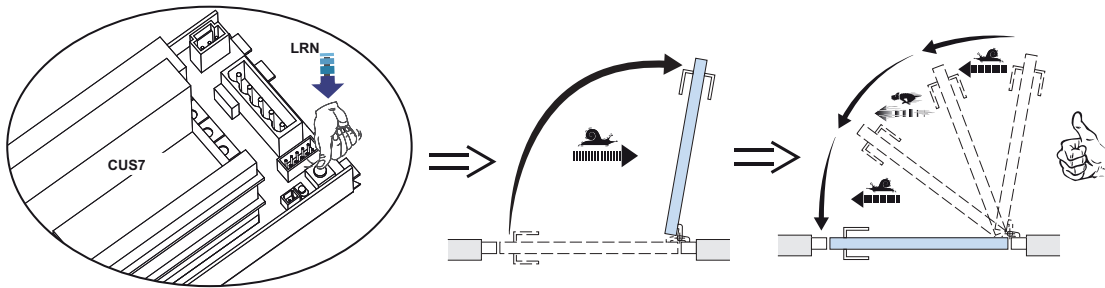

14.4.2 Double doors

For double doors, the primary door must be learned first and thereafter the secondary door. When the secondary door is learned, the primary door will open up to fully open position during the learning phase of the secondary door.

The doors can also be learned separately before connecting the sync cable. In case of rebated doors and separate learning, the primary door must be held open before the secondary door learn is carried out.

14.5 General adjustment

- Set the hold open time with the potentiometer on the control unit.
- Adjust the opening speed (OPSP). Turning clockwise increases the speed.
- Adjust the closing speed (CLSP). Turning counter-clockwise decreases the speed.
- Connect the required activation units.
- Check that the installation complies with AHJ (Authority Having Jurisdiction).

14.6 Connection of activation units and accessories

Refer to the sensor manual for installation and adjustments. The protective device must comply with EN 12978.

Door mounted

When sensors are used in order to avoid contact with the door leaf it is required that the presence detect sensor (PDET) and the presence impulse sensor (PIMP) fulfills the requirement of EN 16005, Performance Level C according to EN ISO 13849-1. These sensors shall also be monitored (tested) by Ditec DAB305 door operator. Enable monitoring by removing corresponding DMPS.SS DMPS.NS jumper on EXU-SA board, refer to page 78.

***** Note! When using the quick connector, opening and closing side will be reversed.**

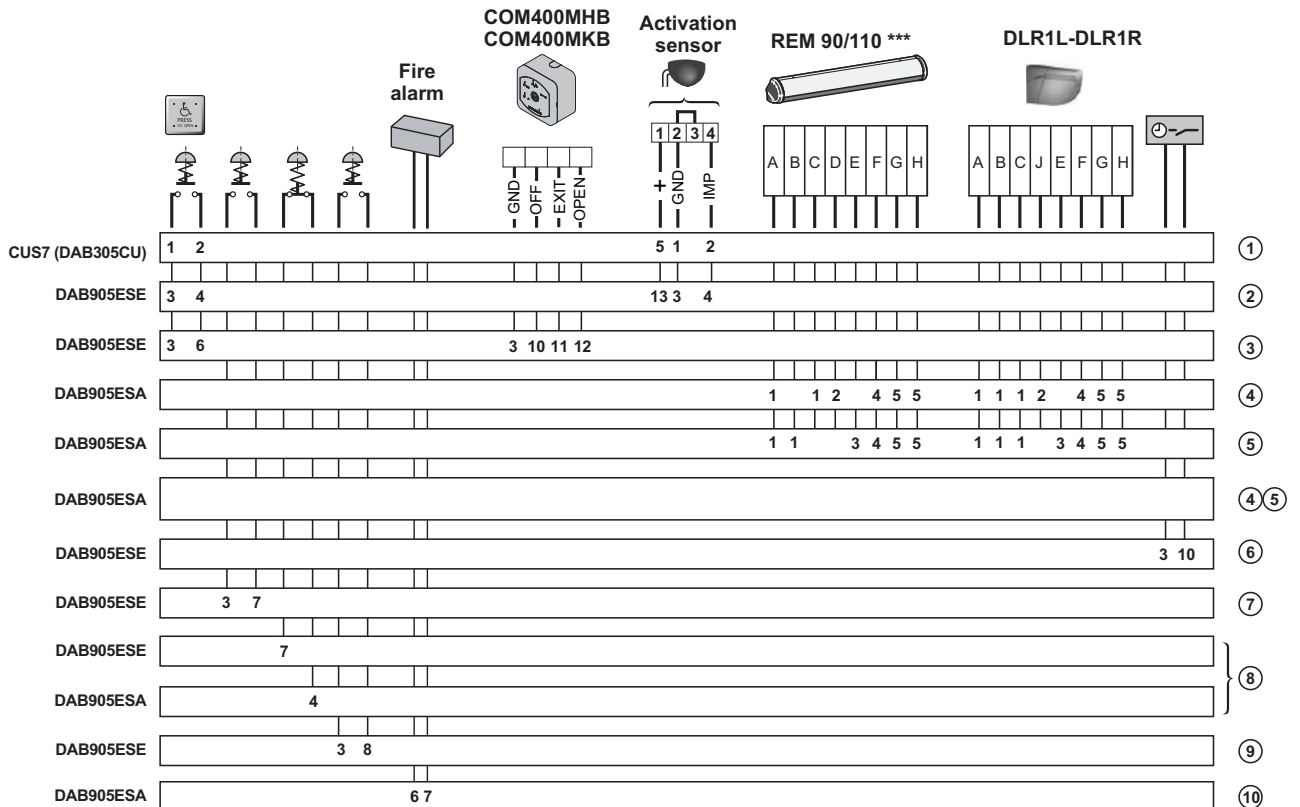

15 Cover

The cover and back plate are manufactured in clear anodized aluminum. The end plates are made of grey painted steel sheet.

15.1 Fitting and removing the cover

The cover is slid over flanges in the back plate so that the ridges fit in the grooves. Snap on the fill cover into the slot for output shaft. Secure cover with the screw.

When properly installed and adjusted, attach the product label, which includes the CE mark on the right side of the lower part of the operator cover (see illustration).

Apply the Ditec logotype to the cover – see illustration.

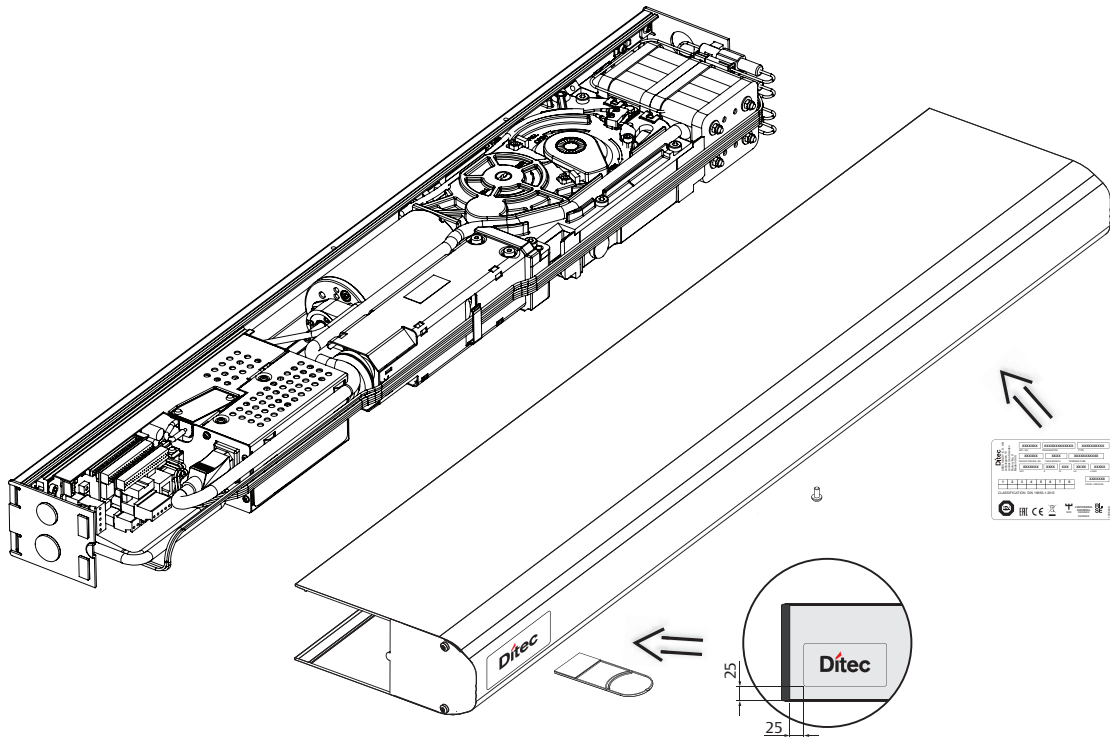

15.2 Cover piece kit DAB05CMP1

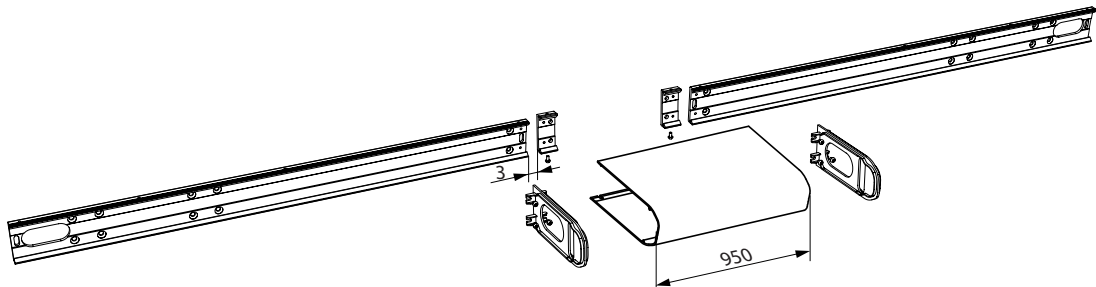

16 Signage



Check that all required signage is applied and intact. Mandatory indicates that the signage is required by European directives and equivalent national legislation outside the European Union.

(A)	Product label: Mandatory
(B)	Emergency break-out: Mandatory, if approved for escape route.
(C)	Door sticker. Mandatory, if applicable to highlight the presence of the glass (applied to all glass sections that are moving).
(D)	Supervision of child (applied to both sides of the door): Mandatory according to national regulations. Recommended, if the risk analysis shows use by children.
(E)	Operator designed for disabled people: Recommended, if applicable (applied to both sides of the door).
(F)	Activation by disabled people: Recommended, if applicable.
(G)	Automatic door. Only mandatory in GB.
(H)	No entry, identifying one-way traffic: Mandatory in GB, if applicable, not included in the product.
(K)	Keep clear. Only mandatory in GB.

17 Advanced settings

Note! Manual latch check and/or back check is rarely needed.

17.1 Learn with advanced setting of “back-check and latch-check”

See the prerequisites for performing a “learn” in section [Auto-learn-automatically sets back and latch check \(recommended\)](#) on page 87.



- a Push the button once as for auto-setting.
The status LED starts to blink. Same as for auto-setting.
- b Stop the door at required open position.
- c The door reverts towards closed position.
- d Stop the door at required latch-check position.
- e The door reverts to learn the back check.
- f Stop the door at required back check.
- g Remove the stop.
- h The door reverts to closed position.

17.2 Revert to default values for “back-check and latch-check” (Level 1)

- a Disconnect batteries if any.
- b Disconnect the mains.
- c Press the LEARN BUTTON (LRN) and keep it depressed.
- d Connect the mains.
- e Watch the ERROR LED.



- f Release the LEARN BUTTON after 1 flash (LED is out).
- g The BACK CHECK, LATCH CHECK and OPEN POSITION have now reverted to default values.
- h Disconnect the mains.
- i Next time the mains is connected, a new learn is needed to be run, and the operator will use the default values.

17.3 Changing group of parameters (Level 2)

- a Disconnect batteries if any.
- b Disconnect the mains.
- c Press the LEARN BUTTON (LRN) and keep it depressed.
- d Connect the mains.
- e Watch the ERROR LED.

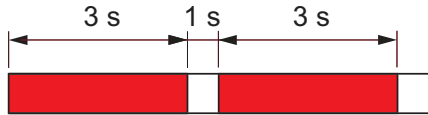

- f Release the LEARN BUTTON after 2 flashes (LED is out).
The ERROR LED flashes a number of short flashes that corresponds to the parameter group number (see table). After a short pause the LED will repeat the group number, and so on.
- g Pushing the LEARN BUTTON once, increases the parameter group number. When the highest parameter group number is reached it will start with number 1 (default) again.
- h Push the button until you get the requested parameter group. Ensure that the requested group of parameters has been selected by counting the number of flashes.
- i Disconnect the mains.
- j Next time the mains is connected, the operator will use the new group of parameters.

Parameter/ Group	1 (default)	2	3	4	5	6	7	8	9	10
OPEN/CLOSE HOLD OPEN TIME	15 minutes	Infinite	15 minutes	15 minutes	15 minutes	15 minutes	15 minutes	15 minutes	15 minutes	15 minutes
Battery mode	Power save	Power save	Convenience	Power save	Power save	Power save	Power save	Power save	Power save	Convenience
KILL mode	Locked during KILL	Locked during KILL	Locked during KILL	Lock follows program selector during KILL	Locked during KILL	Locked during KILL	Locked during KILL	Locked during KILL	Lock follows program selector during KILL*	Locked during KILL
OBSTRUCTION mode¹⁾	Door closer	Door closer	Door closer	Door closer	Reverses when obstructed	Door closer	Door closer	Door closer	Door closer	Reverses when obstructed
DOUBLE EGRESS mode	Separate presence detection	Separate presence detection	Separate presence detection	Separate presence detection	Separate presence detection	Common presence detection	Separate presence detection	Separate presence detection	Separate presence detection	Separate presence detection
LOCK RETRY²⁾	On	On	On	On	On	On	Off	On	On	On
OPEN/CLOSE impulse	In AUTO mode	In AUTO mode	In AUTO mode	In AUTO mode	In AUTO mode	In AUTO mode	In AUTO mode	In OFF, EXIT and AUTO mode	In AUTO mode	In AUTO mode
KILL Impulse Configuration²⁾	Normally Open	Normally Open	Normally Open	Normally Open	Normally Open	Normally Open	Normally Open	Normally Open	Normally Closed Monitored	Normally Open
Relay²⁾	Error indication	Error indication	Error indication	Error indication	Error indication	Error indication	Error indication	Error indication	Error indication	Error indication
Double acting²⁾	No	No	No	No	No	No	No	No	No	No

* The lock unlocks at impulse during KILL in EXIT mode.

1) If set to REVERSES WHEN OBSTRUCTED, the operator re-opens when obstructed, similar to a presence impulse.

2) In double door installations, for secondary this parameter will follow the parameter group chosen at the secondary, regardless primary config.

In the default setting, if there is a bind with the strike plate when the door is closing the door will try to close two extra times in automatic operation, OFF or EXIT mode and once in manual operation. This function can be switched off (see "LOCK RETRY" and parameter group 7), and in a double-door application secondary must be configured separately (see note 2) about why.

Parameter/ Group	11	12	13	14	15	16	17	18	19	20	21
OPEN/CLOSE HOLD OPEN TIME	15 minutes	15 minutes	15 minutes	15 minutes	Infinite	Infinite	15 minutes	15 minutes	15 minutes	15 minutes	15 minutes
Battery mode	Power save	Power save	Power save	Power save	Convenience	Convenience	Power save	Convenience	Power save	Power save	Convenience
KILL mode	Unlocked during KILL	Unlocked during KILL	Locked during KILL	Unlocked during KILL	Locked during KILL	Locked during KILL	Unlocked during KILL	Lock follows prog. Selector during KILL*	Unlocked during KILL	Unlocked during KILL	Unlocked during KILL
OBSTRUCTION mode¹⁾	Door closer	Door closer	Door closer	Door closer	Reverses when obstructed	Reverses when obstructed	Reverses when obstructed	Reverses when obstructed	Door closer	Reverses when obstructed	Door closer
DOUBLE EGRESS mode	Separate presence detection	Separate presence detection	Separate presence detection	Separate presence detection	Separate presence detection	Separate presence detection	Separate presence detection	Separate presence detection	Separate presence detection	Separate presence detection	Separate presence detection
LOCK RETRY²⁾	On	On	On	On	On	On	On	On	On	On	On
OPEN/CLOSE impulse	In AUTO mode	In AUTO mode	In AUTO mode	In AUTO mode	In OFF, EXIT and AUTO mode	In OFF, EXIT and AUTO mode	In AUTO mode	In AUTO mode	In AUTO mode	In AUTO mode	In AUTO mode
KILL Impulse Configuration²⁾	Normally Open	Normally Closed Monitored	Normally Closed Monitored	Normally Closed Monitored	Normally Open	Normally Closed Monitored	Normally Closed Monitored	Normally Closed Monitored	Normally Closed Monitored	Normally Closed Monitored	Normally Closed Monitored
Relay²⁾	KILLout	KILLout	KILLout	Lock	Lock	Lock	Error indication	Error indication	Error indication	Error indication	Error indication
Double acting²⁾	No	No	No	No	No	No	No	No	Yes	Yes	Yes

* The lock unlocks at impulse during KILL in EXIT mode.

1) If set to REVERSES WHEN OBSTRUCTED, the operator re-opens when obstructed, similar to a presence impulse.

2) In double door installations, for secondary this parameter will follow the parameter group chosen at the secondary, regardless primary config.

In the default setting, if there is a bind with the strike plate when the door is closing the door will try to close two extra times in automatic operation, OFF or EXIT mode and once in manual operation. This function can be switched off (see "LOCK RETRY" and parameter group 7), and in a double-door application secondary must be configured separately (see note 2) about why.

Note! If relay output is used for Lock even at secondary, use parameter group 15 in secondary.

In double door installations with Double Acting, secondary must have same parameter group as primary.

17.4 Classification (Level 3)

- a Disconnect batteries if any.
- b Disconnect the mains.
- c Press the LEARN BUTTON (LRN) and keep it depressed.
- d Connect the mains.
- e Watch the ERROR LED.

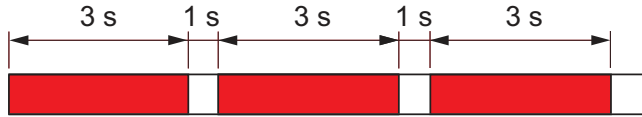

- f Release the LEARN BUTTON after 3 flashes (LED is out).
- g Identify the current classification
The ERROR LED flashes an amount of short flashes that correspond to the classification number. After a short pause the LED will repeat the classification number and so on.
- h Changing the classification
If you push the LEARN BUTTON once, the classification number will increase. When you have reached the highest classification number it will start at number one again.
 - Push the button until you get the requested classification
 - Disconnect the mains
 Next time the mains is connected, the operator will use the new classification.

i Classification table

Classification	1*	2	3	4	5	6
Full power** / Low energy***	Full power	Low energy	Full power	Low energy	Full power	Low energy
PIMP in manual	Close	Close	Reopen	Reopen	Stop	Stop

* Default Setting

** Full Power, Opening speed is 2.5 to 12s, Closing Speed is 4 to 12s.

*** Low energy, the operator will automatically follow the speed limitation in EN 16005, Closing/Opening speed: Automatic limitation 1.69 J.

Classification 3-6 is valid for software versions 2.2.6 or above.

Presence Impulse behavior in manual opening (PIMP in manual):

Close: PIMP and PDET are disabled when no activation impulse (such as inner/outer) is detected.
 Reopen: When closing after manual opening, PIMP will re-open door and enter automatic operation.

Stop: PIMP during closing after manual opening, will stop door movement until sensor field is clear.

The Learn procedure must be carried out after a change of the classification setting.

The fastest setting of Opening Speed and Closing Speed are automatically limited to the value in the table, and can only be reduced.

If classification 2, Low energy, is used the operator will automatically follow the speed limitation in EN 16005.

The learn procedure must be carried out after a change of the classification setting.

Speed settings for Low energy mode

The table shows minimum opening time to back check or to 80° open or minimum closing time from 90° to 10° open.

Width of door leaf (mm)	Door mass (kg)				
	50	60	70	80	90
	Time (s) min				
750	3.0	3.2	3.2	3.3	3.5
850	3.1	3.1	3.2	3.4	3.6
1000	3.2	3.4	3.7	4.0	4.2
1200	3.8	4.2	4.5	4.8	5.1

17.5 Overhead Presence Detection and Interlock (Level 4)

- a Disconnect batteries if any.
- b Disconnect the mains.
- c Press the LEARN BUTTON (LRN) and keep it depressed.
- d Connect the mains.
- e Watch the ERROR LED.

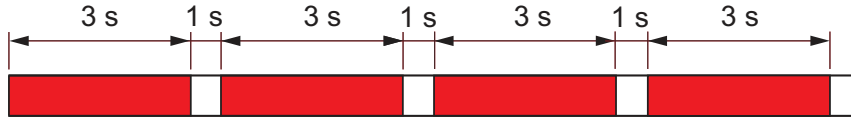

- f Release the LEARN BUTTON after 4 flashes (LED is out).
- g Identify the current monitoring
The ERROR LED flashes an amount of short flashes that correspond to the status number. After a short pause the LED will repeat the status number and so on.
- h Changing the status
If you push the LEARN BUTTON once, the status number will increase. When you have reached the highest status number it will start at number one again.

Level 4:	1 (Default)	2	3	4	5	6
OPD-monitoring	OFF	ON	OFF	OFF	OFF	OFF
Interlock*	OFF	OFF	Operator 2 to 6 (Locked)	Operator 2 to 6 (Closed)	Operator 1 (Locked)	Operator 1 (Closed)

* Interlock cannot be used together with OPD-sensors. If (Locked) is used the operator must be in EXIT or OFF mode.

- Disconnect the mains
Next time you connect the mains the operator will use the new status setting.

- i Interlocking connections. Can be used as security interlock.

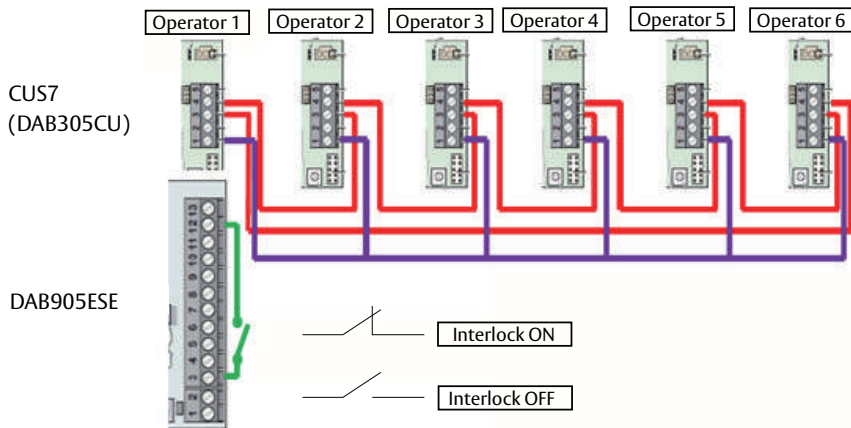

17.6 Enhanced Lock Kick, Fire Input and Extended Arm Selection (Level 5)

- a Disconnect batteries if any.
- b Disconnect the mains.
- c Press the LEARN BUTTON (LRN) and keep it depressed.
- d Connect the mains.
- e Watch the ERROR LED.

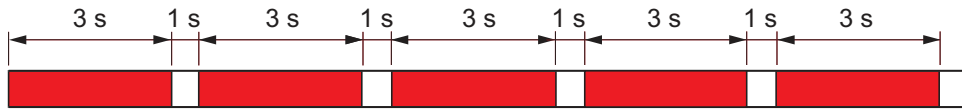

- f Release the LEARN BUTTON after 5 flashes (LED is out).
- g Identify the current lock kick status
The ERROR LED flashes an amount of short flashes that correspond to the status number. After a short pause the LED will repeat the status number and so on.
- h Changing the status
If you push the LEARN BUTTON once, the status number will increase. When you have reached the highest status number it will start at number one again.

Level 5:	1 (Default)	2	3	4	5	6
Lock-Kick Type	Basic	Enhanced	Basic	Enhanced	Basic	Enhanced
Fire Input **	OFF	OFF	12 V	12 V	24 V	24 V
Arm Selection	Basic	Basic	Basic	Basic	Basic	Basic

Level 5:	7	8	9	10	11	12
Lock-Kick Type	Basic	Enhanced	Basic	Enhanced	Basic	Enhanced
Fire Input **	48 V	48 V	OFF	OFF	12 V	12 V
Arm Selection	Basic	Basic	Extended	Extended	Extended	Extended

Level 5:	13	14	15	16
Lock-Kick Type	Basic	Enhanced	Basic	Enhanced
Fire Input **	24 V	24 V	48 V	48 V
Arm Selection	Extended	Extended	Extended	Extended

** When the fire input is used all other configuration has to be done before changing from OFF to 12 V, 24 V or 48 V.

The fire input voltage (Uf) is interpreted as OK / No fire alarm, in the following range: 0.85 x Uf to 1.2 x Uf. Voltage outside this range will activate KILL. Reset is done in the same way as KILL RESET.

Basic Arm Selection	Dip6-7	Extended Arm Selection
PUSH	00	-
PULL	10	DAB805PLA4 (B = 250 mm, A = -20 to 230 mm)
DAB805PLA5		DAB805PLA4 (B = 420 mm, A = -20 to 230 mm)
Sliding PUSH	11	-

- Disconnect the mains
Next time the mains is connected, the operator will use the new status setting.

18 Guide for installation and adjustments

18.1 Complementary Safety Devices Swing Doors

If there is any risk for finger jam, add finger protection strip at the hinge side for internal doors, article No. DAB805FPI or DAB805FP19/20.

18.2 Swing Doors Opening and Closing Time

Adjust, as a minimum, the operator's opening and closing time according to the diagram below.

18.2.1 How to find the correct opening and closing time

- Measure the door width.
- If the door weight is unknown, follow the instructions in "Diagrams for door weight".
- Go into the diagram below to find the correct minimum opening/closing time "t".

Example: If the door width is 1.1 m and the door weight is 80 kg the minimum opening and closing time will be approximate 4.3 seconds.

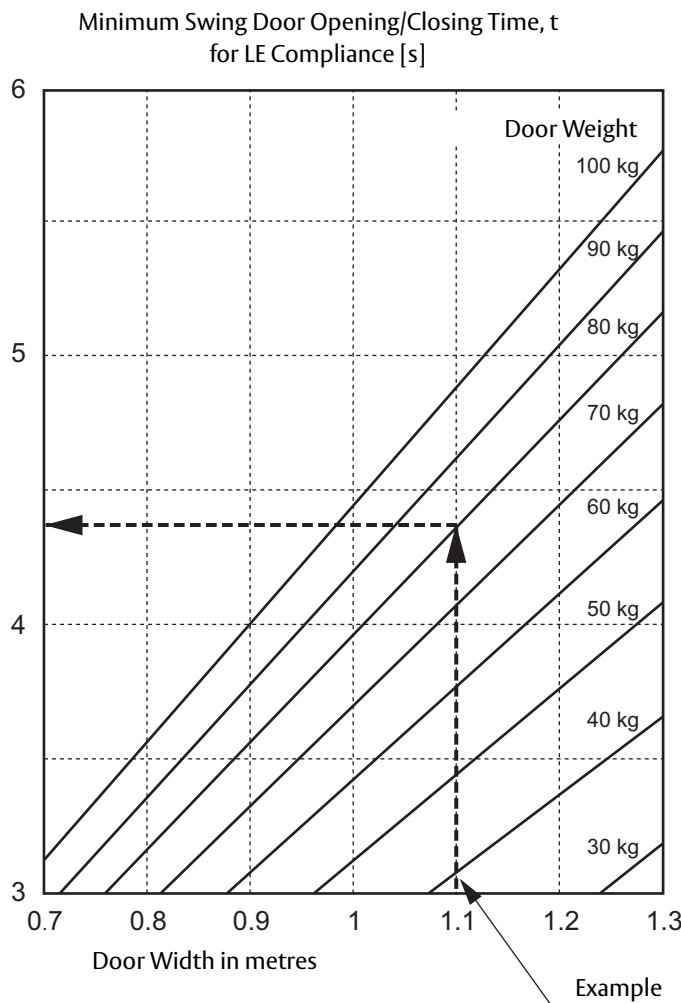

18.3 Diagrams for Door weight

- Measure the door width (DW) and the door height (DH) in metres for one door leaf only.
- Calculate the area $DW \times DH$.
- Select diagram for your type of door and the actual glass thickness. Find the weight.

Example: Aluminum door with measurement $DW = 1.5$ m, $DH = 2$ m and glass thickness 12 mm. Calculate $1.5 \times 2 = 3$ m². Look into the first diagram for "Aluminum Frame with glass". Start with the area and follow the line up to the 12 mm glass, go left to receive the door weight 95 kg.

Note! The weights can vary depending on the door design (the table shows only typical values).

18.3.1 Aluminum frame with glass

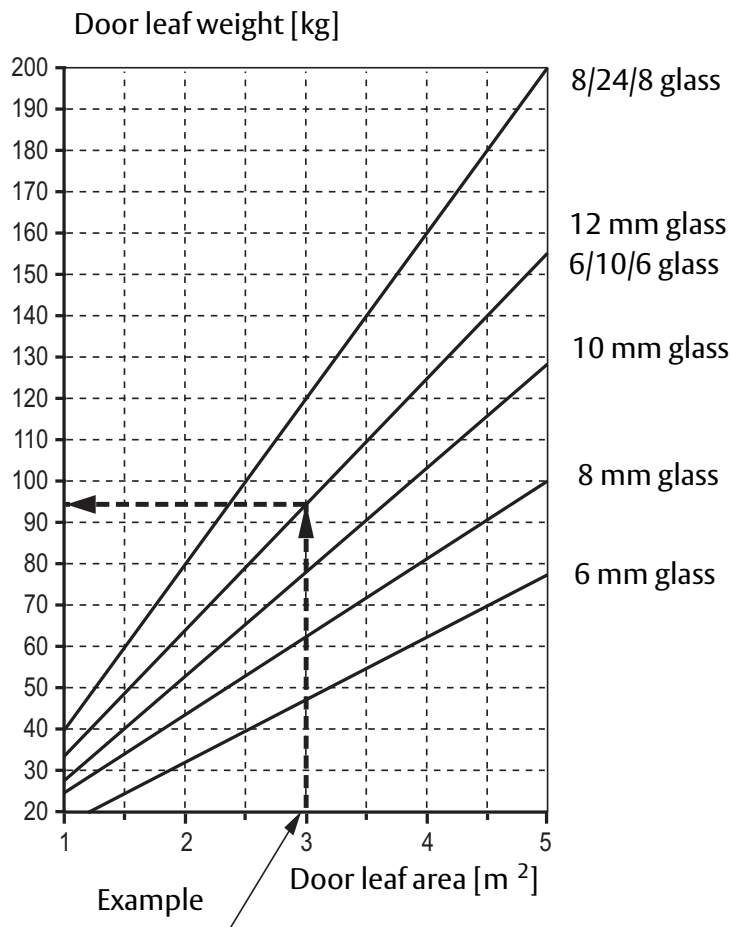

19 Troubleshooting

Fault	Possible reasons why	Remedies/Explanations
The door does not open The motor does not start	Program selector is set to OFF	Change the setting of the program selector
	Mains power is missing	Check the mains power and fuse in the building
	Activation unit does not function	Strap impulse inputs
	Presence detection is activated	Check that there are no objects in the detection zone
The motor starts but the door does not open	Mechanical lock is locked	Unlock the lock
	Something jammed beneath the door	Remove object
	Electric striking plate is binding	Select lock release
		Adjust striking
Arm system has come loose	Tighten the arm system by installation steps	
The door does not close	Program selector is set to OPEN	Change the setting of the program selector
	Presence impulse is activated	Remove objects in the detection zone
	Something jammed beneath the door	Remove object
The door is creeping towards open during power assist	Wrong setting of cam jumper	Check jumper for symmetric cam on main board
The operator works but not at full speed regardless of OPSP and CLSP settings, only Key impulse is valid	Program Off is activated	Switch the program selector
	Sensors are not working	Check external timer/ fire alarm
	Sensor monitoring error LED error code: one 0.3 s flash, 2 s pause etc. Sensors are working!	Check sensor monitoring jumper
		Check if OPD monitoring is activated, see programming level 4, Advanced settings
Main power is lost LED light is only on during opening and closing cycle Sensors are not working	Operator is working with battery backup in Power Save mode. Check power supply	
The arm adaptor is broken	External force or vandalism	It is necessary to replace the arm adaptor and securely tighten it with the specified torque in order to protect the drive unit from damage
Spline-teeth on drive unit shaft are worn down due to a broken adaptor	The operator or door has been used after external force or incorrect tightening torque caused the arm adaptor to break	Replace drive unit and arm adaptor kit and tighten according to the installation instructions
Motor overheated	Door is kept open with wedge or magnet	Wedge or magnet should not be used to hold the door in open position. Instead select OPEN with program selector.
The door slams close uncontrolled when power failure	Lock kick might be disconnected or faulty micro switch	Check if micro switch is working and is connected properly.

19.1 LED indication

- During normal operation the status LED on the control unit is illuminated.
- An extinguished LED indicates that there is no electrical power.
- A flashing light on the LED indicates that the operator generating a message (see table below).

LED message	Reason	Remedy
One 0.3 s flash, 10 s pause etc.	Kill impulse is active	Make a kill reset, reset kill switch or re-set fire alarm
One 0.3 s flash, 0.3 s pause etc.	Learn is active	Wait for learn to complete

Error indication	Reason	Remedy
One 0.3 s flash, 2 s pause etc.	+ 24 V DC external error (no function on the operator)	Check for short circuit
	Sensor monitoring error (Key impulse opens door)	Check for broken monitored sensor or faulty settings
Two 0.3 s flashes, pause etc.	Battery defective*	Replace battery (normal operation with electrical mains). If Battery Monitoring DIP is ON, then probably a reset of this is needed (after changed batteries), see section 6.5.6.)
Three 0.3 s flashes, pause etc.	Control unit or Transmission unit defect	Replace control unit or Transmission unit
Four 0.3 s flashes, pause etc.	Encoder error	Check the encoder cable. Open and close the door manually and thereafter check the automatic function. If the operator is still out of function replace the drive unit.
Five 0.3 s flashes, pause etc.	Locking device defective or lock with too high current draw	Check for e.g. short circuit in the locking device Replace locking device
	DAB905ESE board defective	Replace DAB905ESE board
Six 0.3 s flashes, pause etc.	Sync cable not connected or defective (double door only)	Connect the sync cable
		Replace the sync cable
Seven 0.3 s flashes, pause etc.	Secondary control unit defective (double door only)	Check the flash frequency on the secondary LED and take necessary measures in accordance with this table.
Eight 0.3 s flashes, pause etc.	Motor overheated	Wait for the motor to cool down
Nine 0.3 s flashes, pause etc.	Blocked door and constant impulse	Toggle impulse
Ten 0.3 s flashes, pause etc.	Settings have been made that requires a new learn or opening angle out of spec (80-110°)	Make a new learn or adjust opening angle to be inside spec
Twelve 0.3 s flashes, pause etc.	Motor connected to wrong socket or wrong arm system configured on AS-dips.	Disconnect mains and then correct motor connection and correct arm systems dips.
Thirteen 0.3 s flashes pause etc.	Interlock error	Check Interlock Connection

20 Service/Maintenance

Regular inspections shall be made according to national regulations and product documentation by a Ditec-trained and qualified technician. The number of service occasions should be in accordance with national requirements and product documentation. This is especially important when the installation concerns a fire-approved door or a door with an emergency opening function.

As with all other technical products, an automatic door needs maintenance and service. It is essential to know the importance of maintenance to have a reliable and safe product.

Service and adjustments will ensure a safe and proper operation of an automatic door unit.

This product may contain batteries that should only be replaced by a Ditec-trained and skilled technician.

Risk of battery explosion if wrong type of battery is used. If Battery Monitoring DIP is ON, then a reset of this is needed (after changed batteries), see page [20](#).



ASSA ABLOY Entrance Systems AB, Lodjursgatan 10, SE-261 44 Landskrona, Sweden
www.ditecautomations.com