

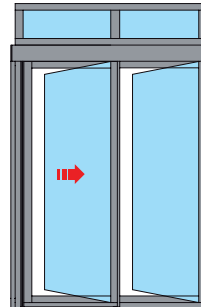

- Versione aggiornata di questo manuale
- Last version of this manual

# Ditec

IP2189 • 2024-06-14

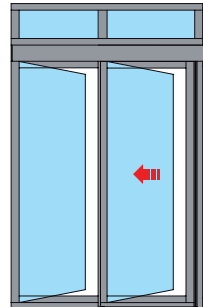
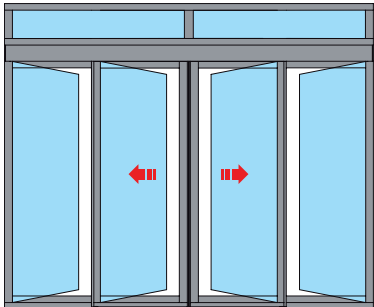
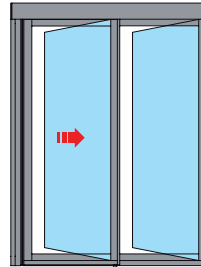
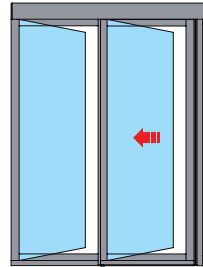
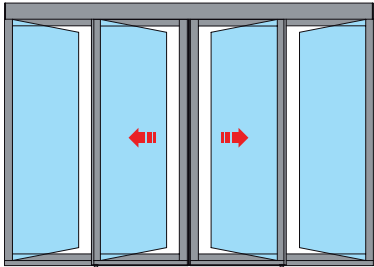

**EN** Installation instructions for ALU48 with break-out device of the moving and the fixed door wings (Original instructions)

**IT** Istruzioni di installazione sistema profili ALU48 a sfondamento delle ante fisse e delle ante mobili (Istruzioni originali)

## Ditec ALU48TB0

# 1. Instructions for placing panes on door wing

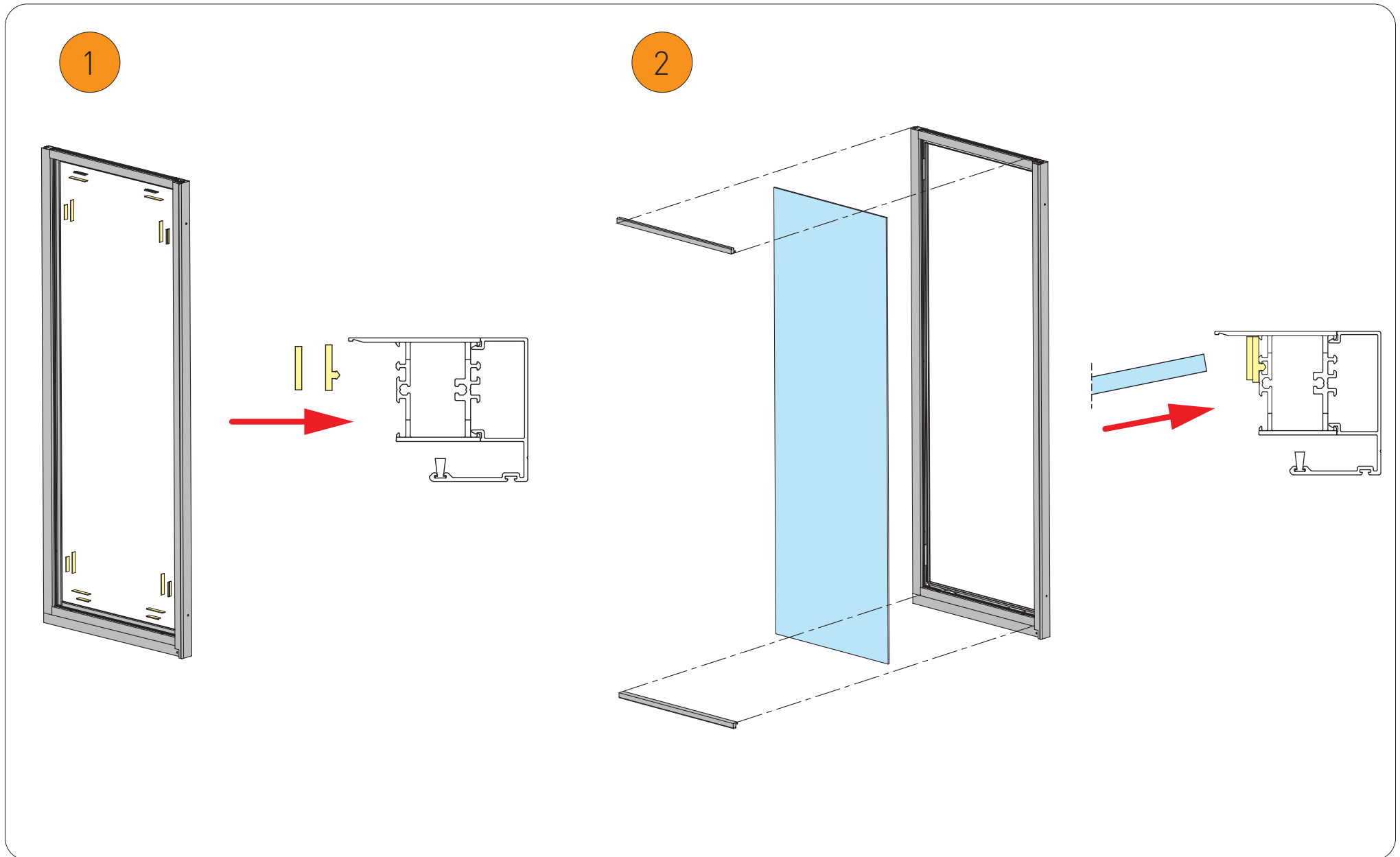

# 1. Instructions for placing panes on door wing

3

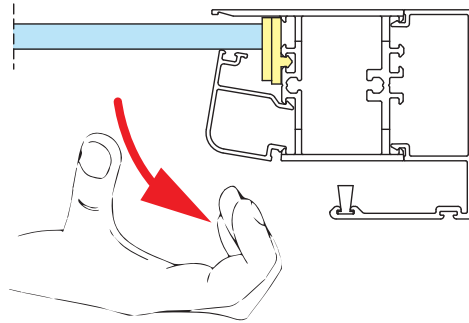
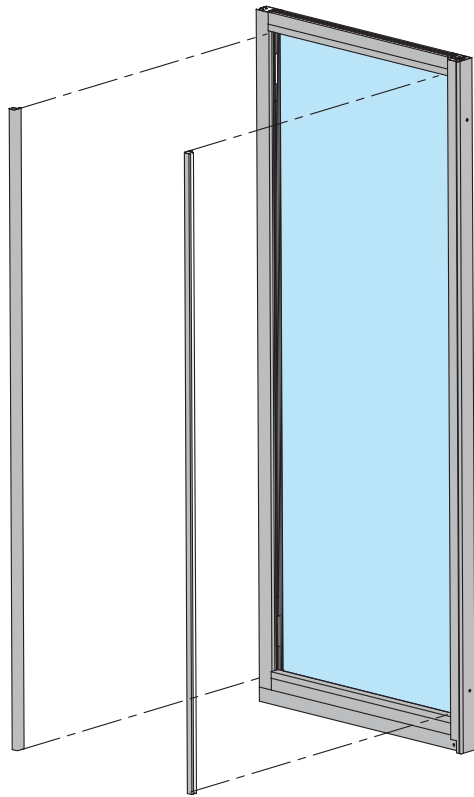

4

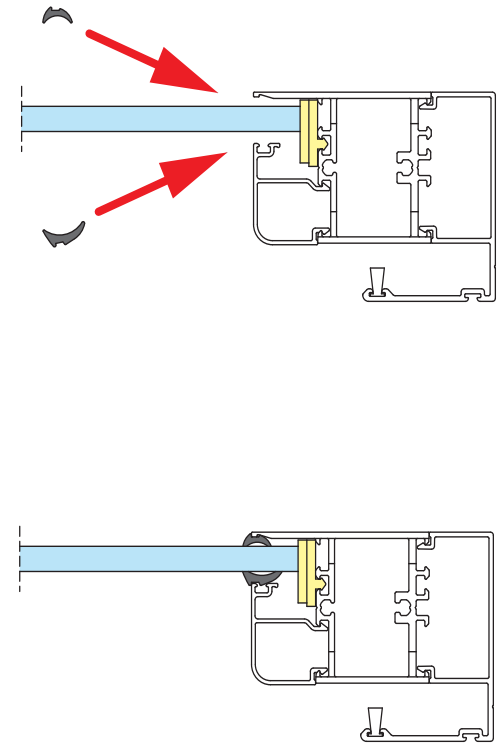
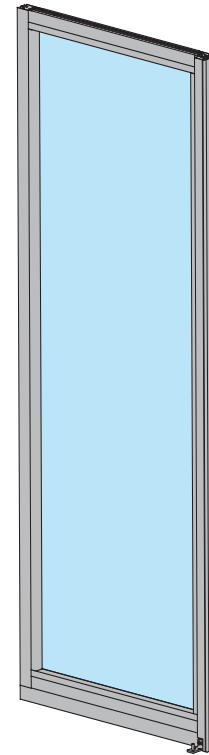

## 2. Installation instructions

List of equipment  
Elenco dotazioni  
Ausstattungsverzeichnis  
Liste des accessoires fournis  
Lista de suministro  
Lista de equipamentos

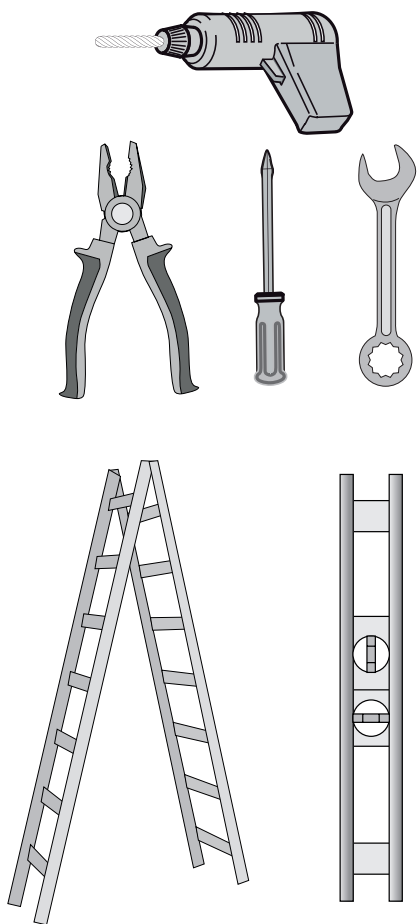

Regulation instructions  
Indicazioni di regolazione  
Angaben zur Einstellung  
Indications de réglage  
Indicaciones de regulación  
Indicações de regulação

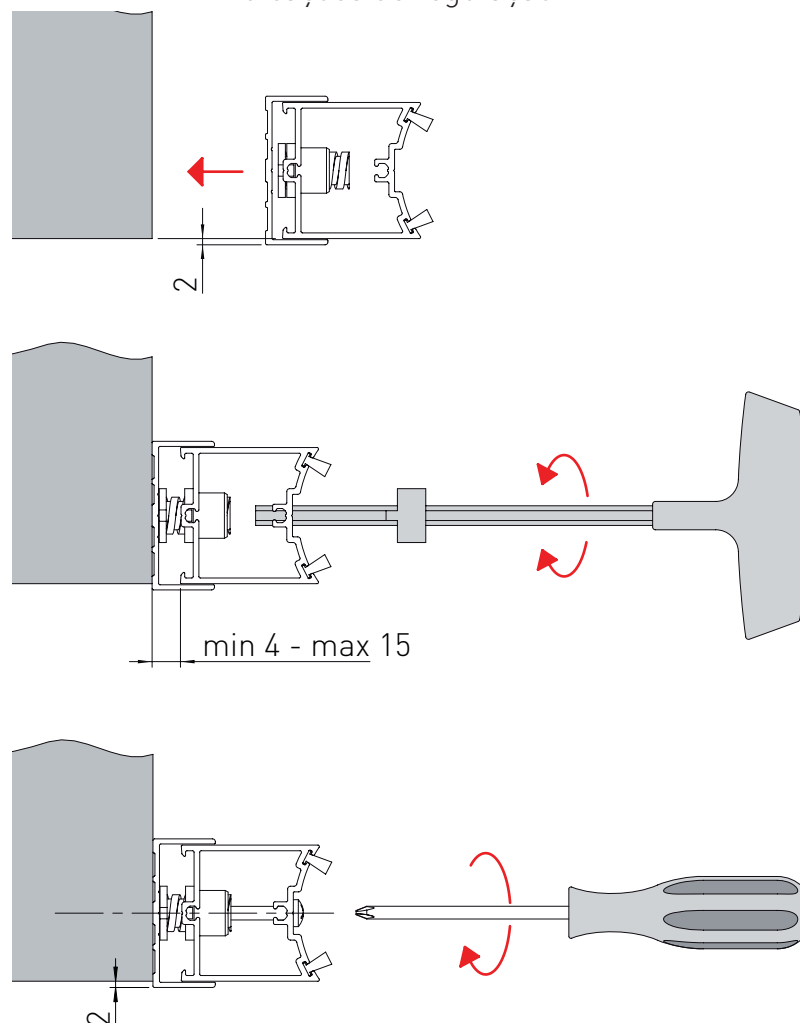

Fastening instructions  
Indicazioni di fissaggio  
Angaben zur Befestigung  
Indications de fixation  
Indicaciones de fijación  
Indicações de fixação

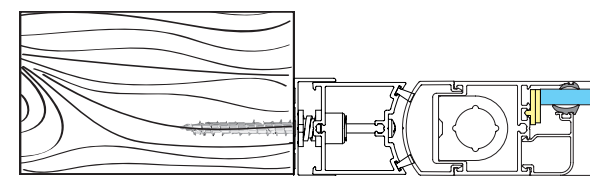

Wood - Legno - Holz  
Bois - Madera - Madeira

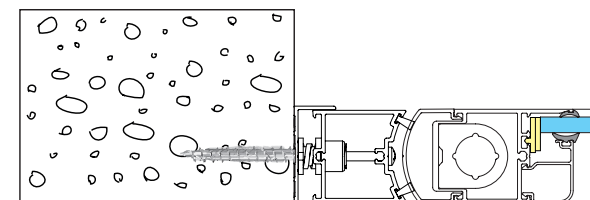

Concrete - Cemento - Zement  
Ciment - Cemento - Concreto

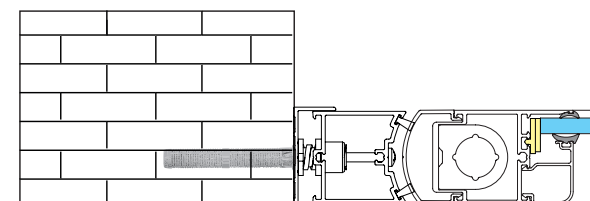

Brick - Mattone - Ziegel  
Brique - Ladrillo - Tijolo

### 3. Installation instructions for two moving door wings and two fixed wings without beam

- 1 Installation position  
NB: check LxH dimensions

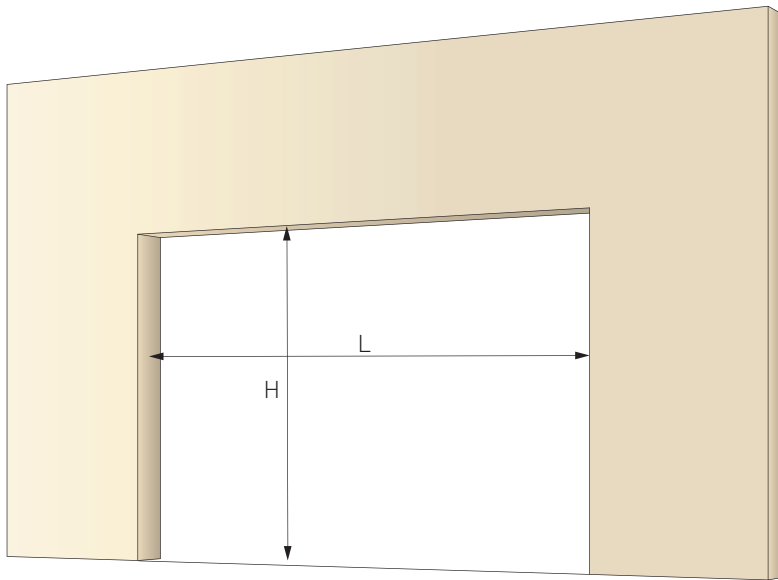

- 2 Installation of frame

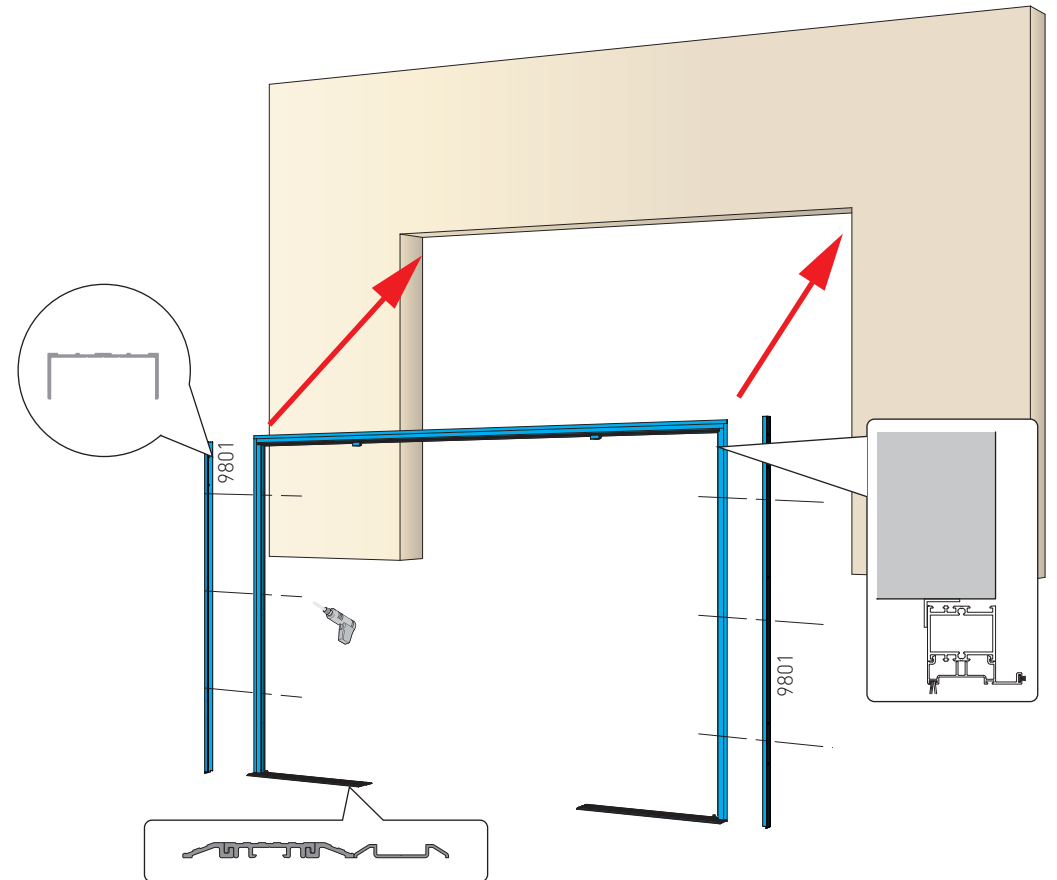

### 3. Installation instructions for two moving door wings and two fixed wings without beam

#### 3 Frame installation

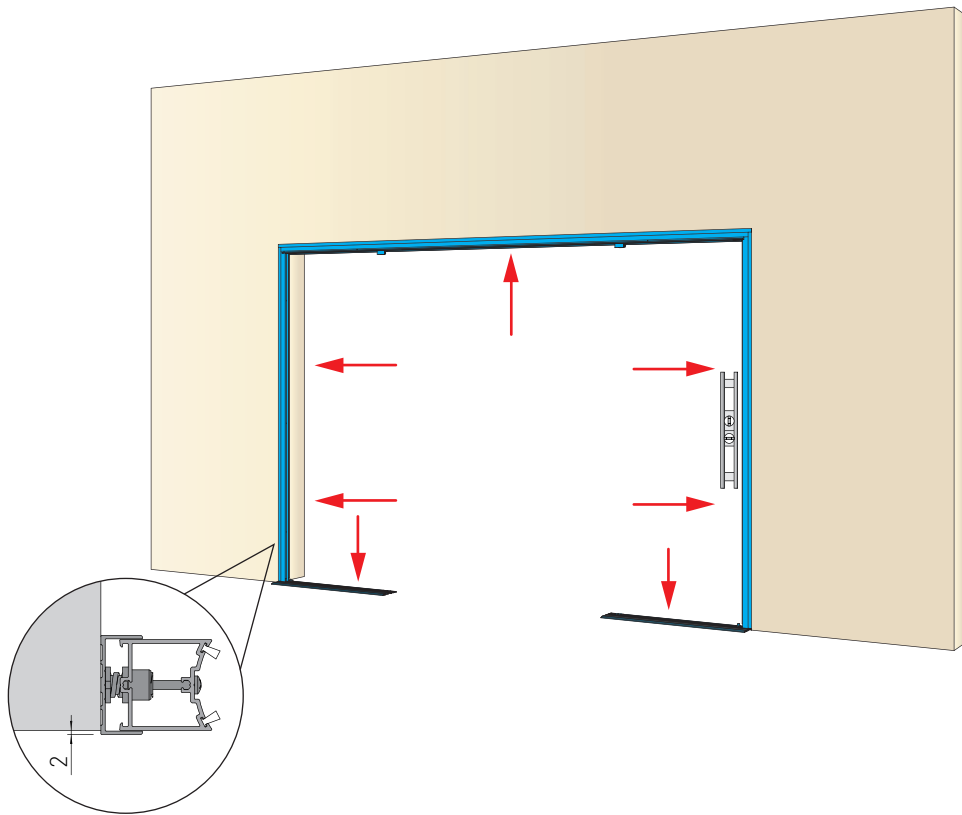

#### 4 Fixed door wings installation

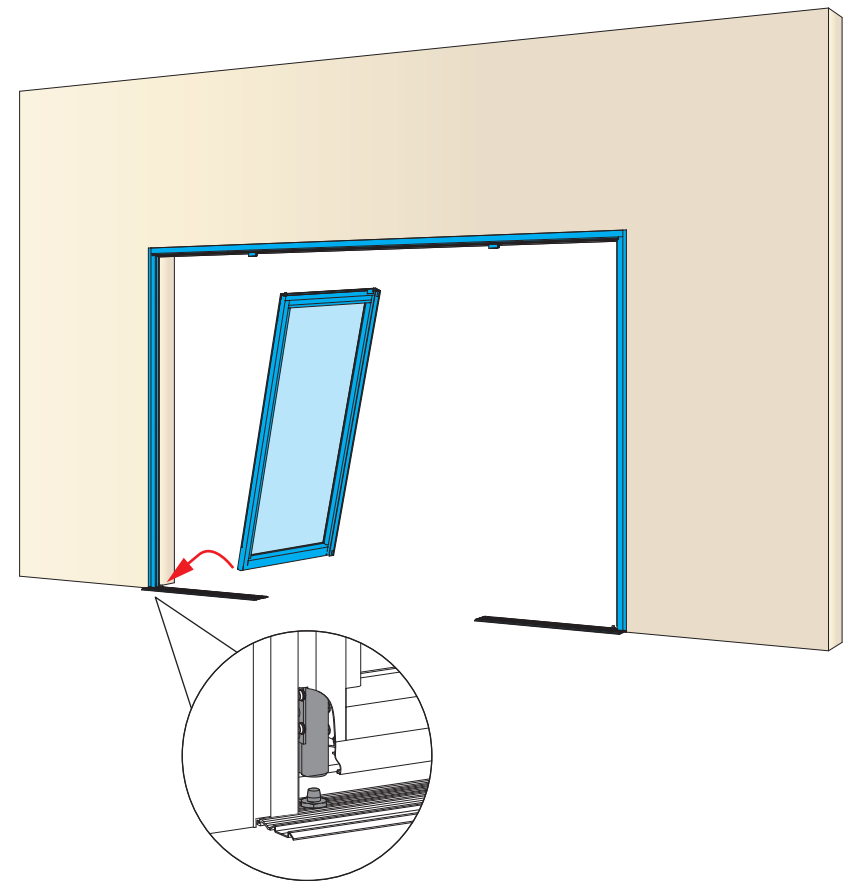

### 3. Installation instructions for two moving door wings and two fixed wings without beam

#### 5 Fixed door wings installation

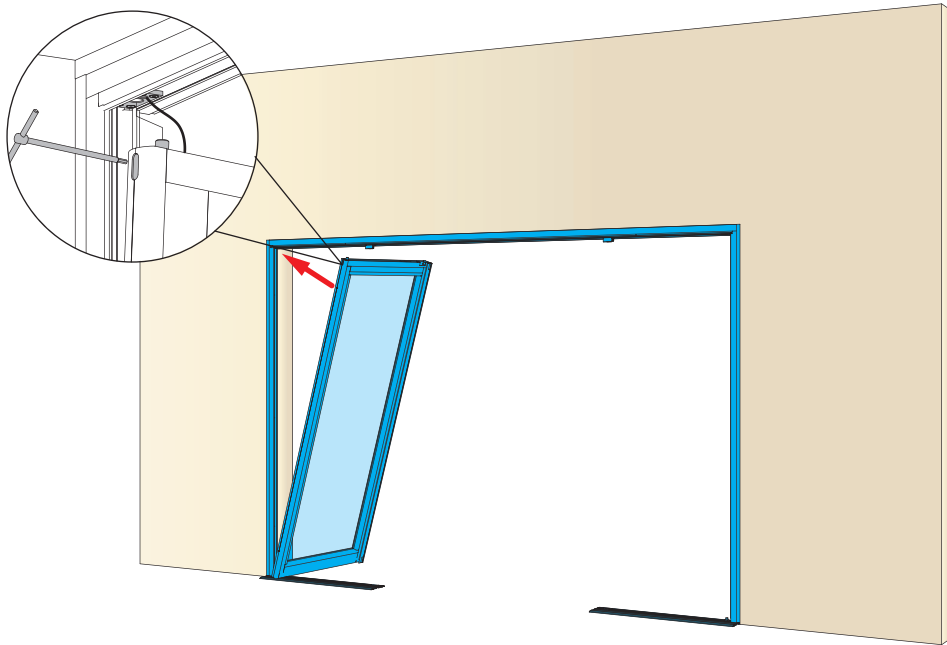

#### 6 Fixed door wings regulation

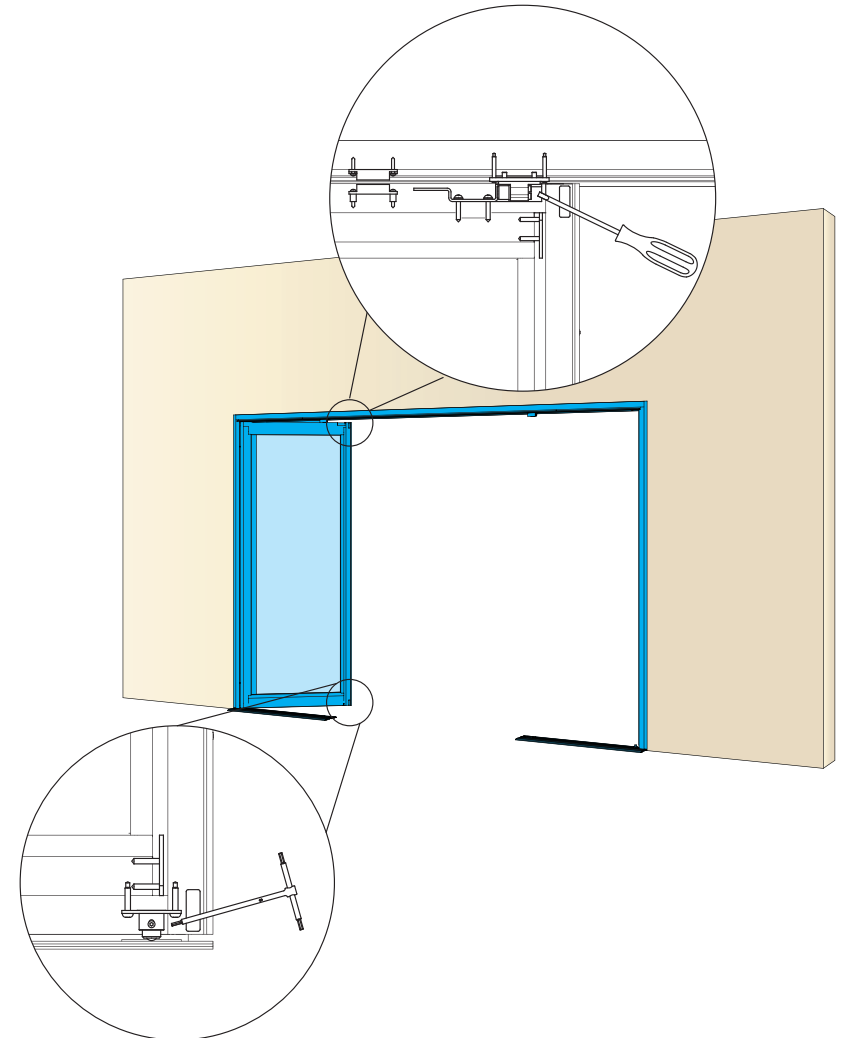

### 3. Installation instructions for two moving door wings and two fixed wings without beam

7 Fixed door wings installation

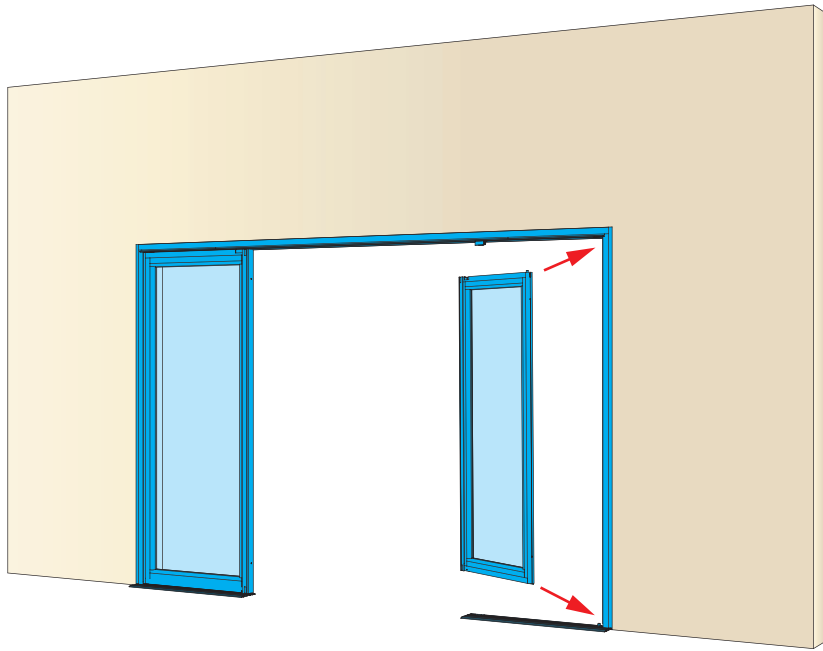

8 Installation of the automation

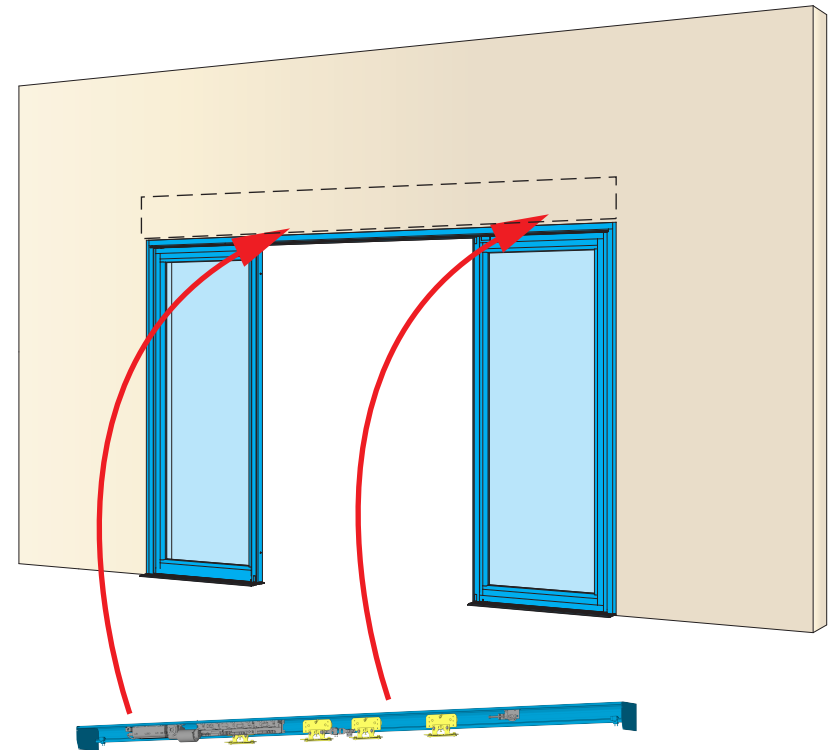

### 3. Installation instructions for two moving door wings and two fixed wings without beam

9 Door wings installation

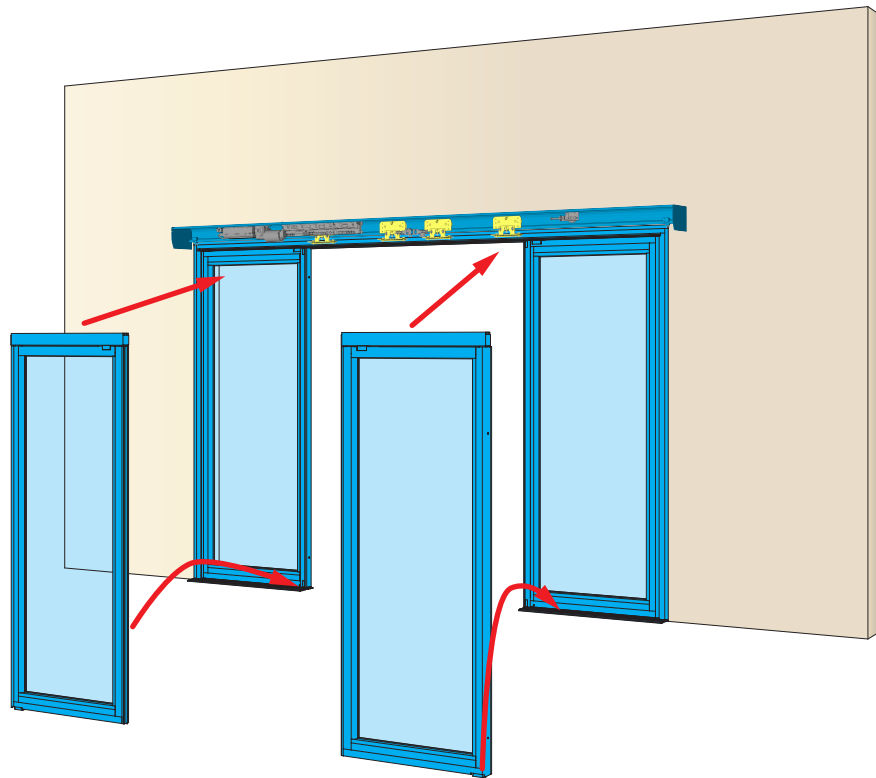

10 Moving door wing regulation

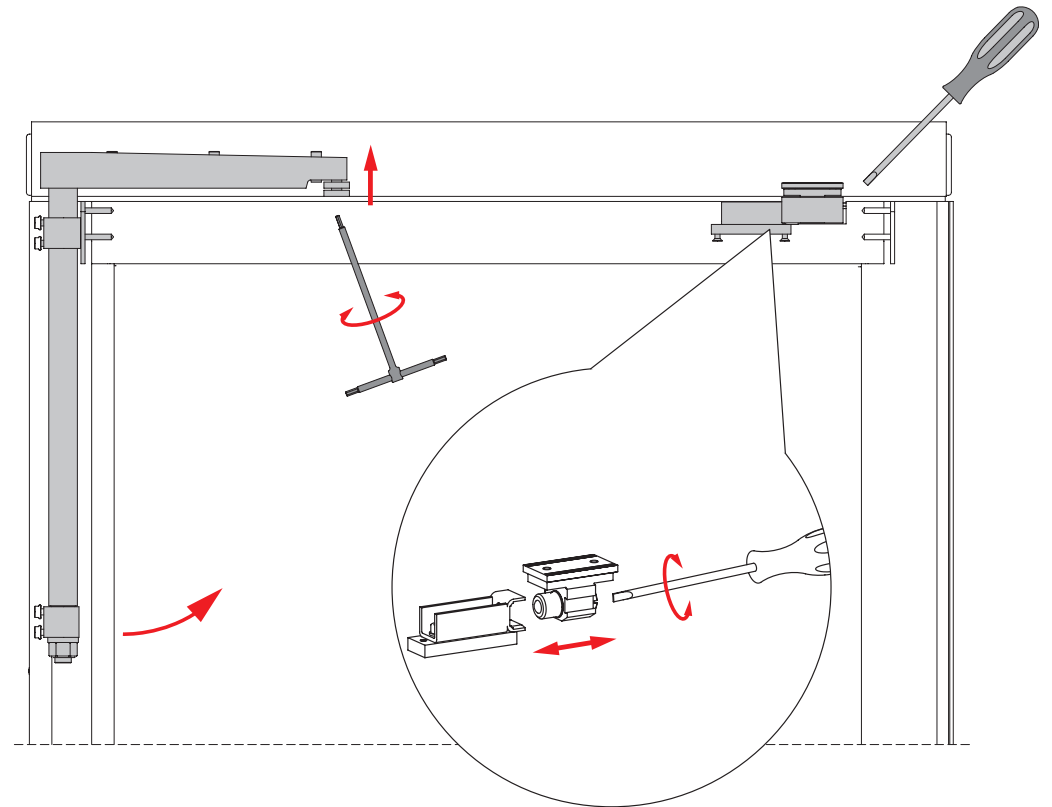

### 3. Installation instructions for two moving door wings and two fixed wings without beam

11 Casing installation

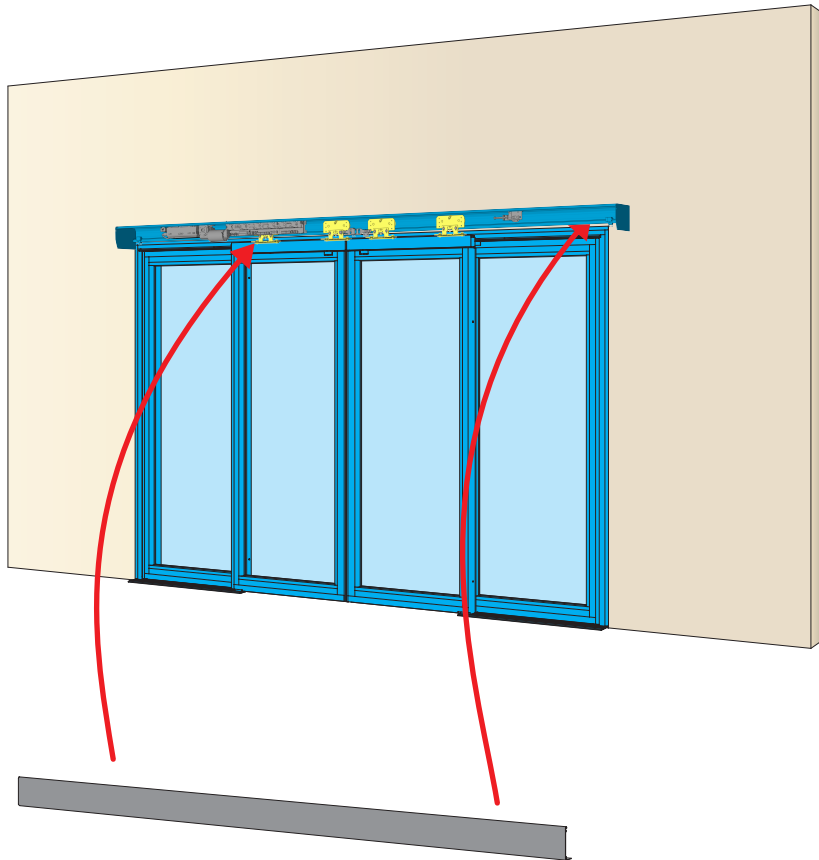

12 End of installation

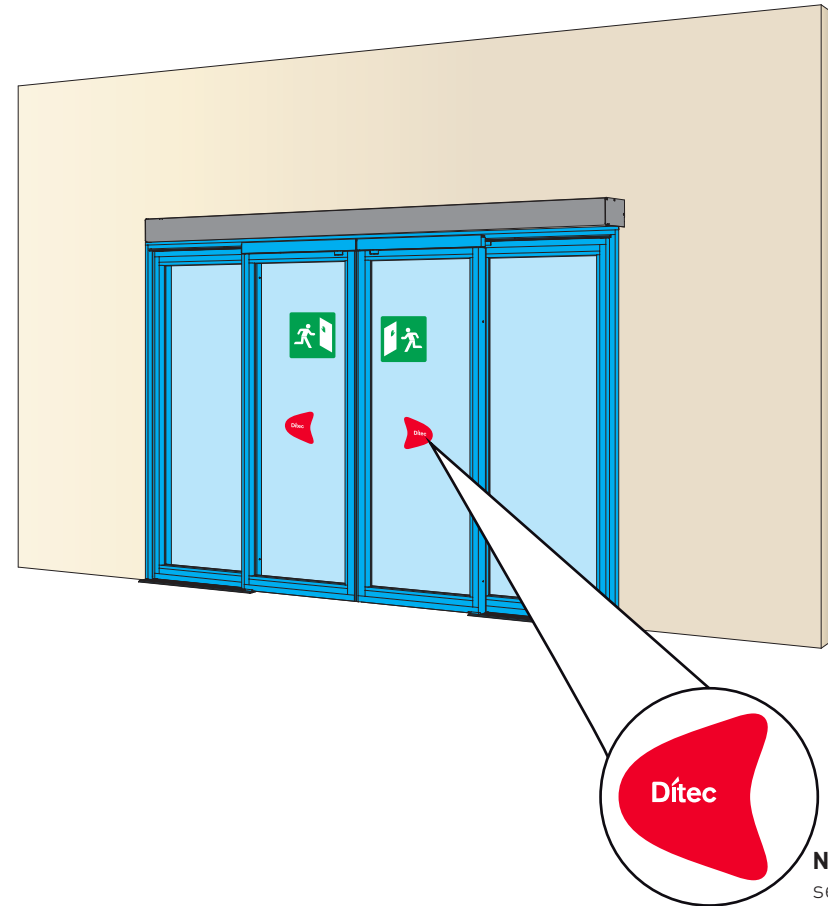

## 5. Installation instructions for one moving door wing and one fixed door wing with beam

- 1 Installation position  
NB: check LxH dimensions

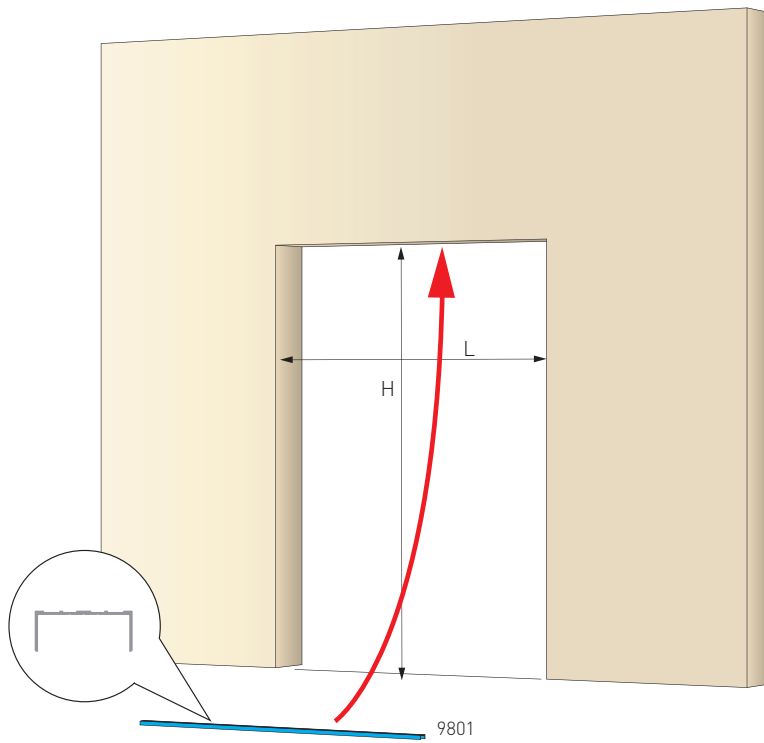

- 2 Frame installation

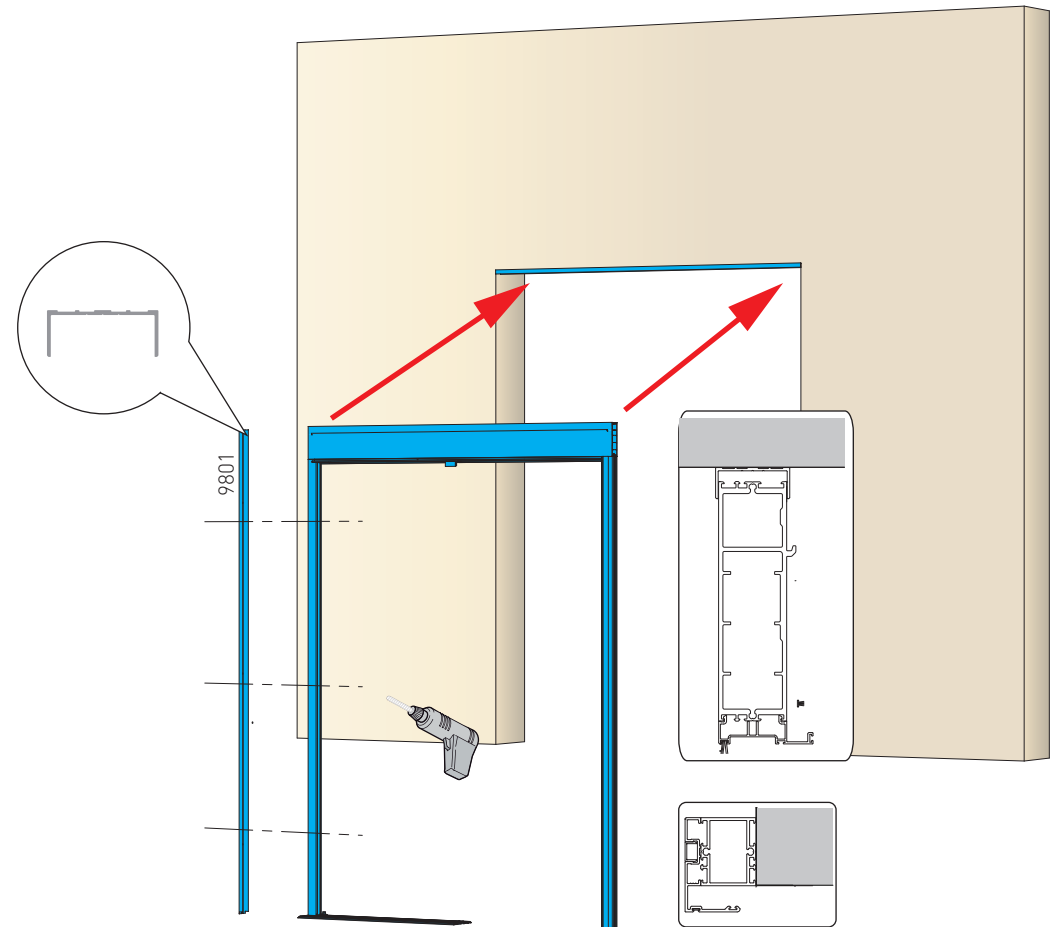

## 5. Installation instructions for one moving door wing and one fixed door wing with beam

### 3 Beam installation

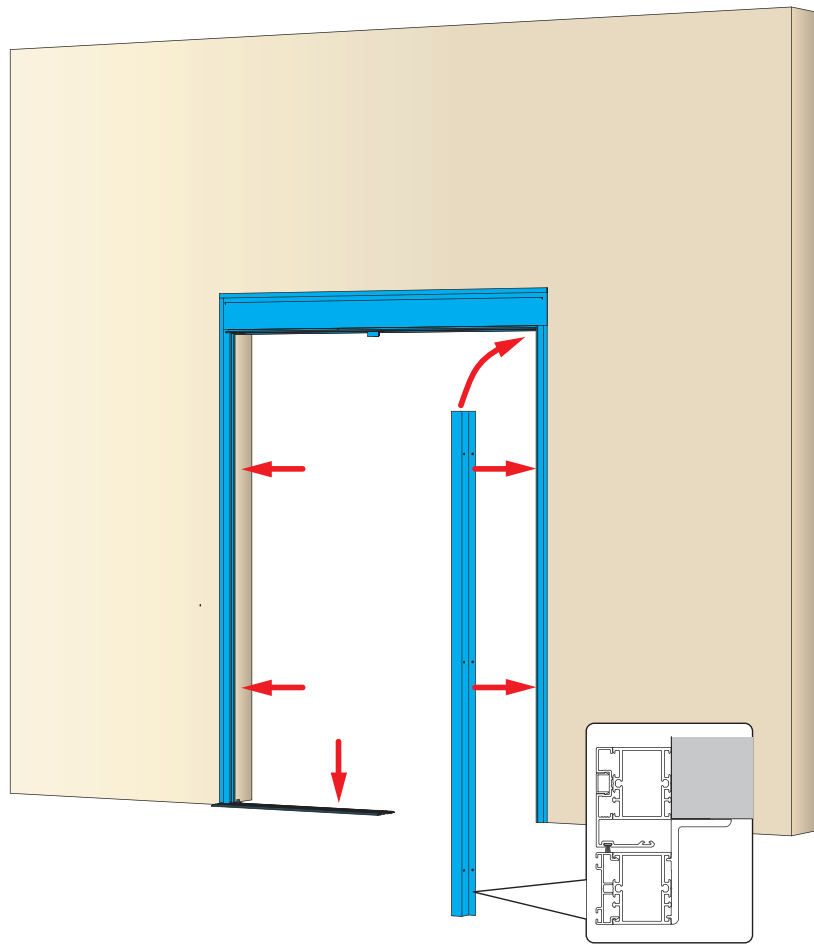

### 4 Fixed door wing installation

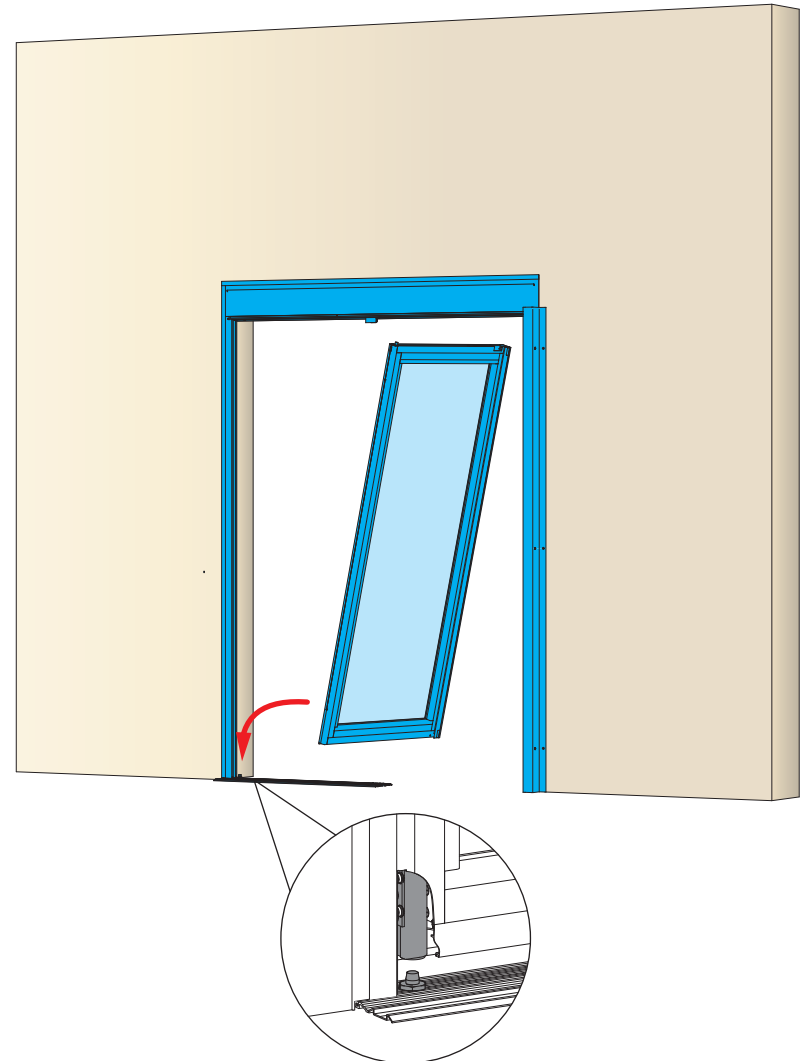

## 5. Installation instructions for one moving door wing and one fixed door wing with beam

### 5 Fixed door wing installation

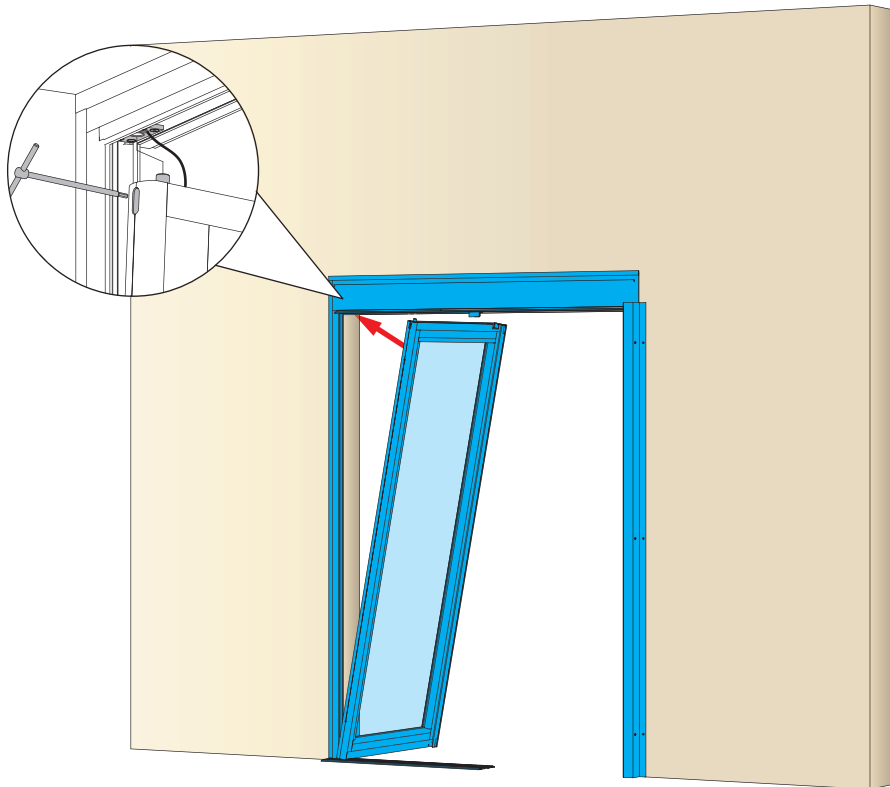

### 6 Fixed door wing regulation

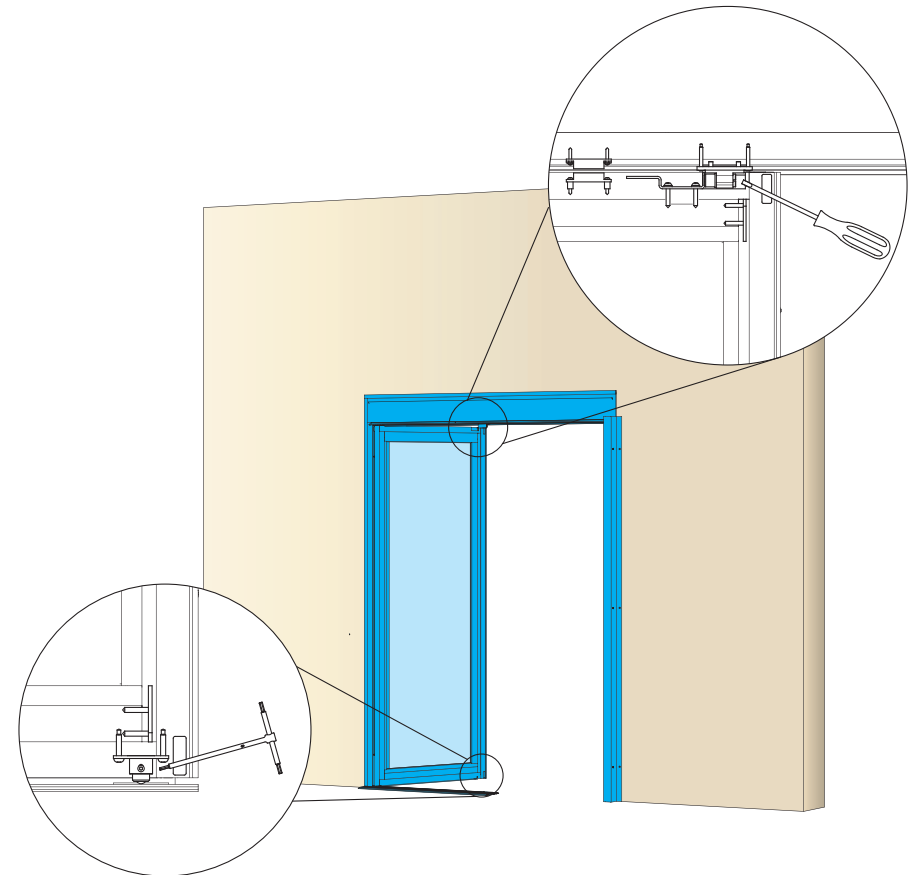

## 5. Installation instructions for one moving door wing and one fixed door wing with beam

### 7 Installation of automation

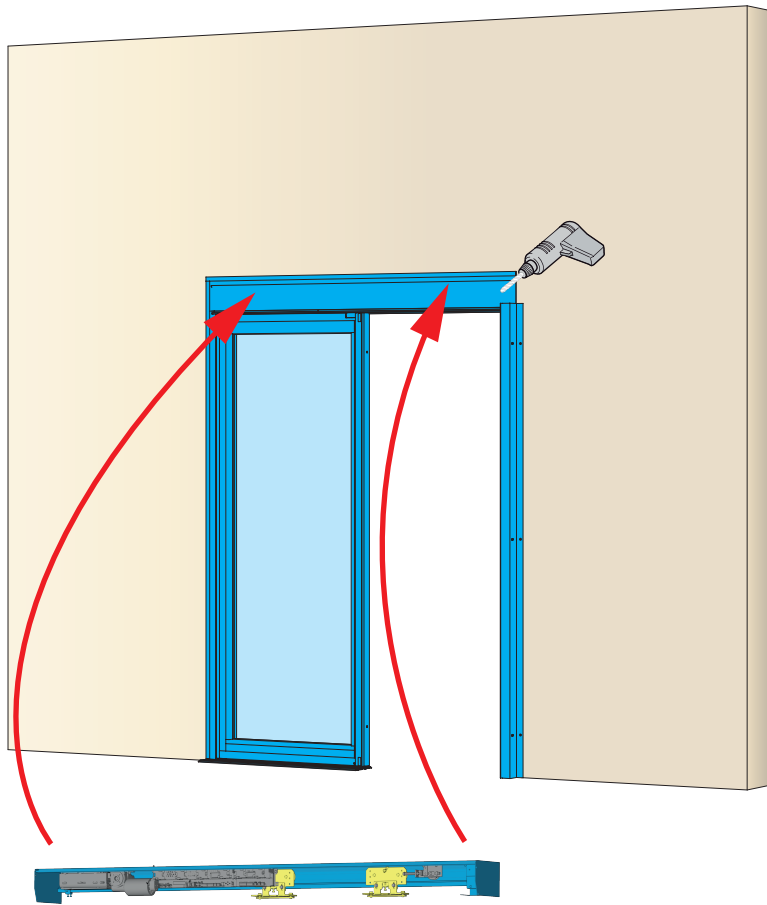

### 8 Door wing installation

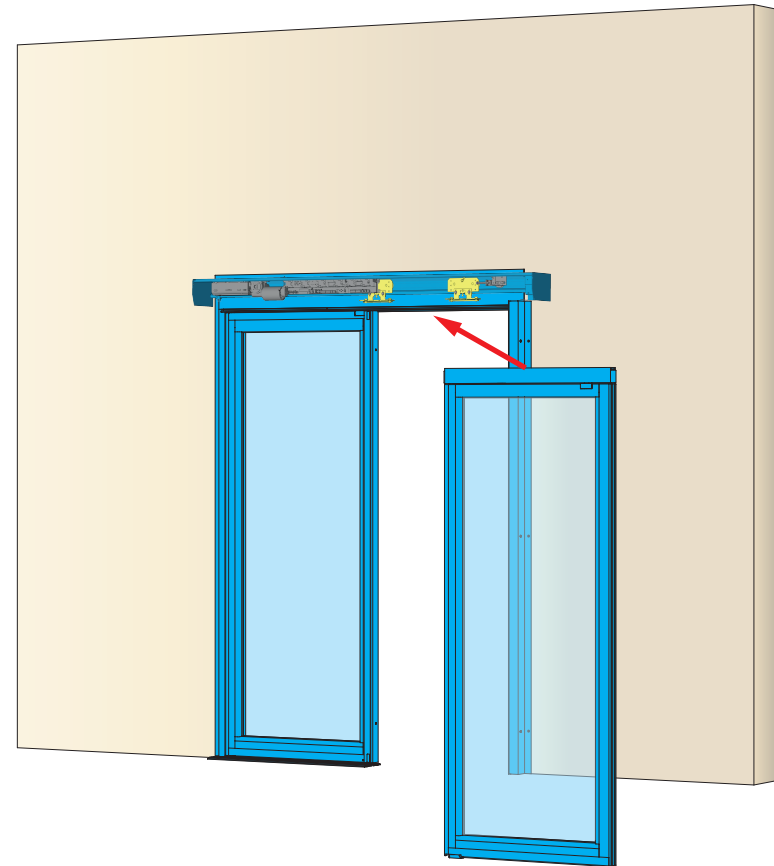

## 5. Installation instructions for one moving door wing and one fixed door wing with beam

### 9 Door wing regulation

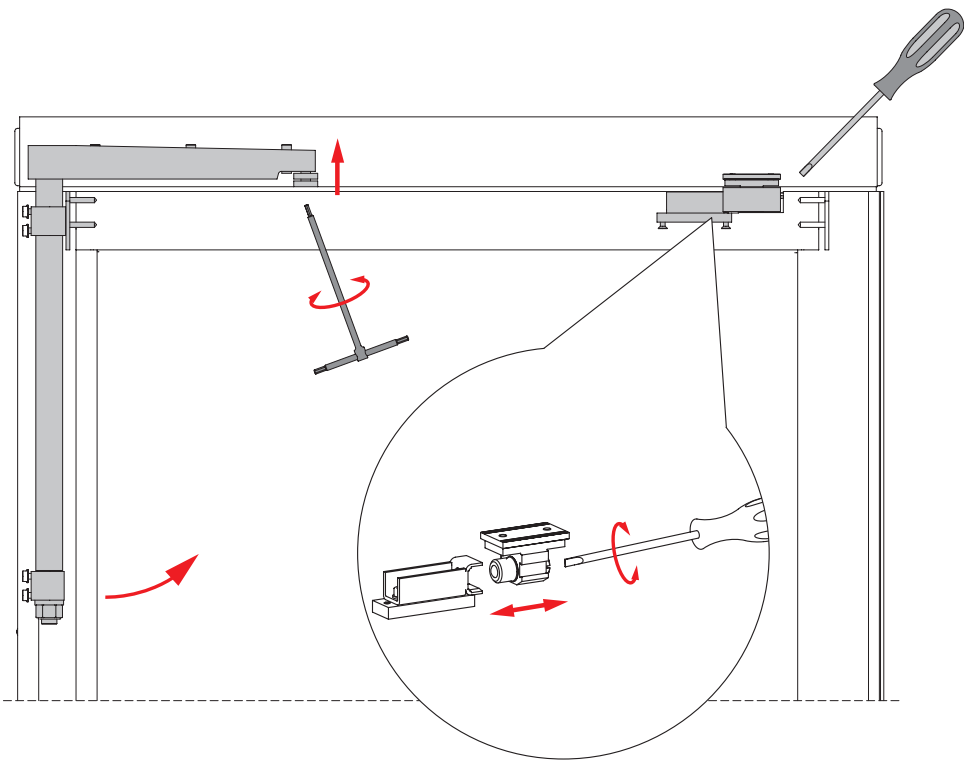

### 10 Casing installation

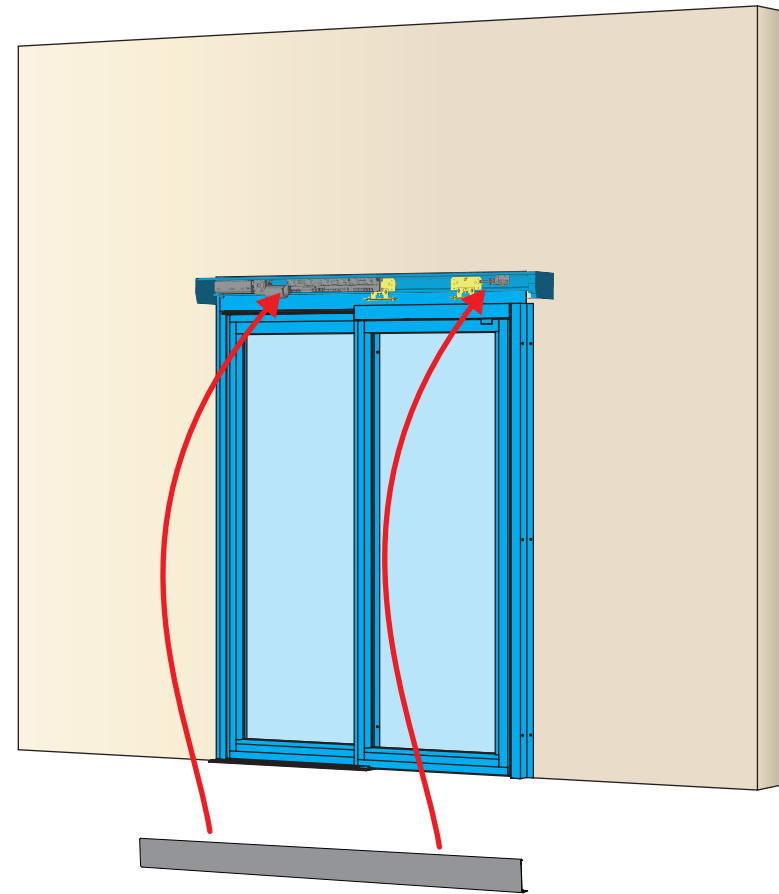

## 5. Installation instructions for one moving door wing and one fixed door wing with beam

11 End of installation

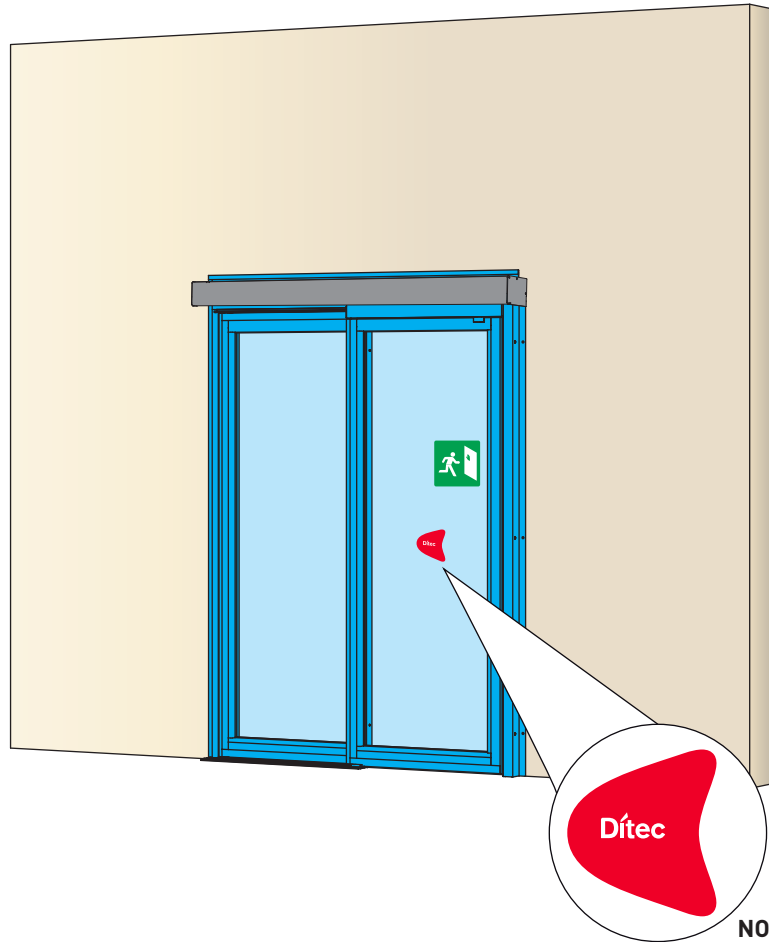

**NOTE 1**  
see page 23

## 6. Installation instructions for two moving door wings and two fixed door wings with beam and overlight

- 1** Installation position  
NB: check LxH dimensions

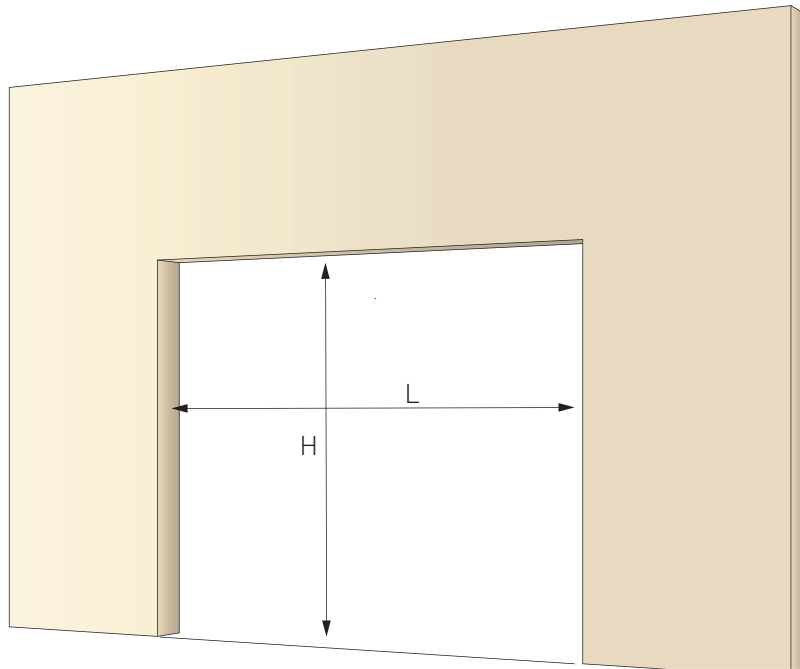

- 2** Frame assembling

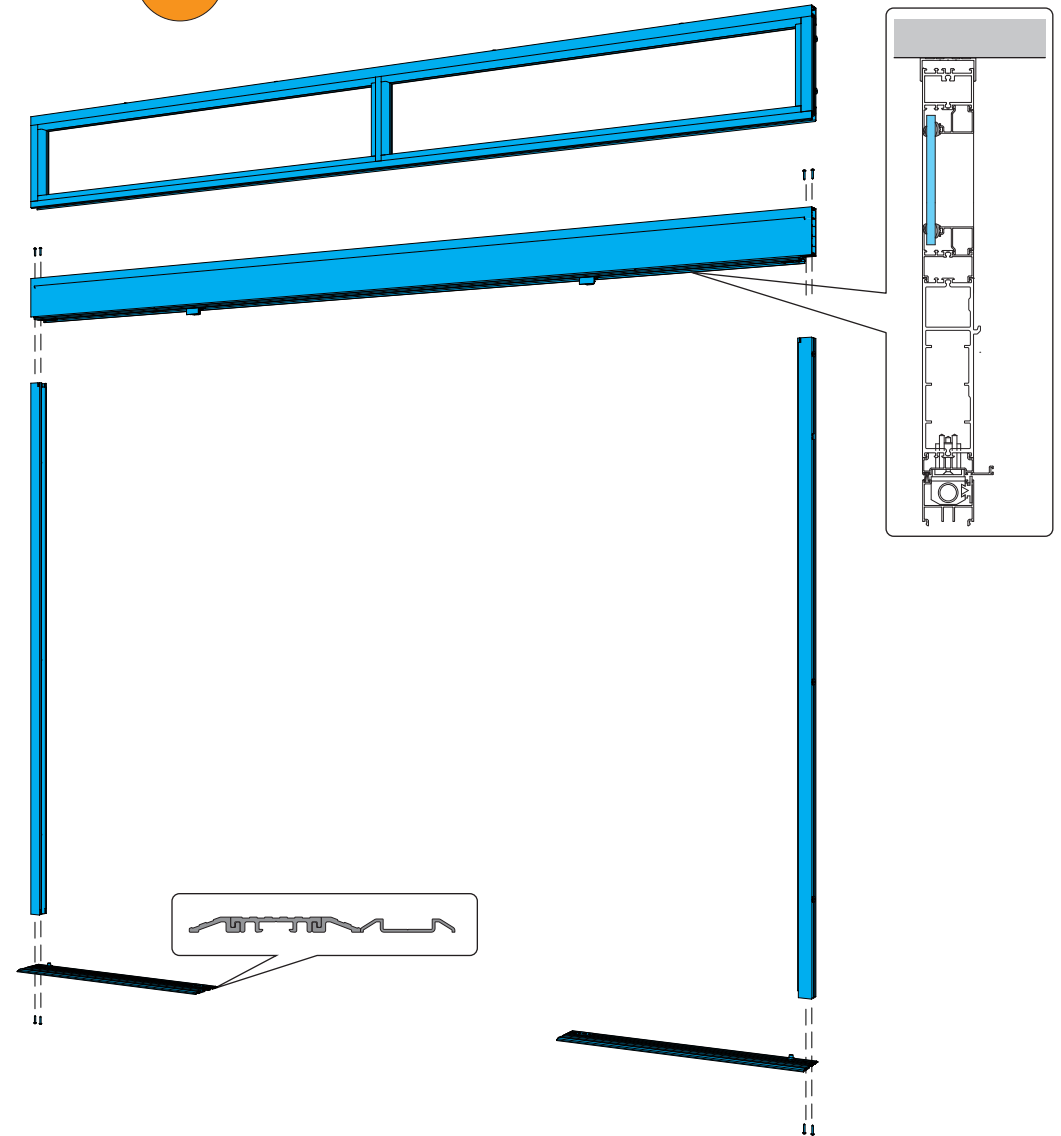

## 6. Installation instructions for two moving door wings and two fixed door wings with beam and overlight

3 Frame, beam and overlight assembling

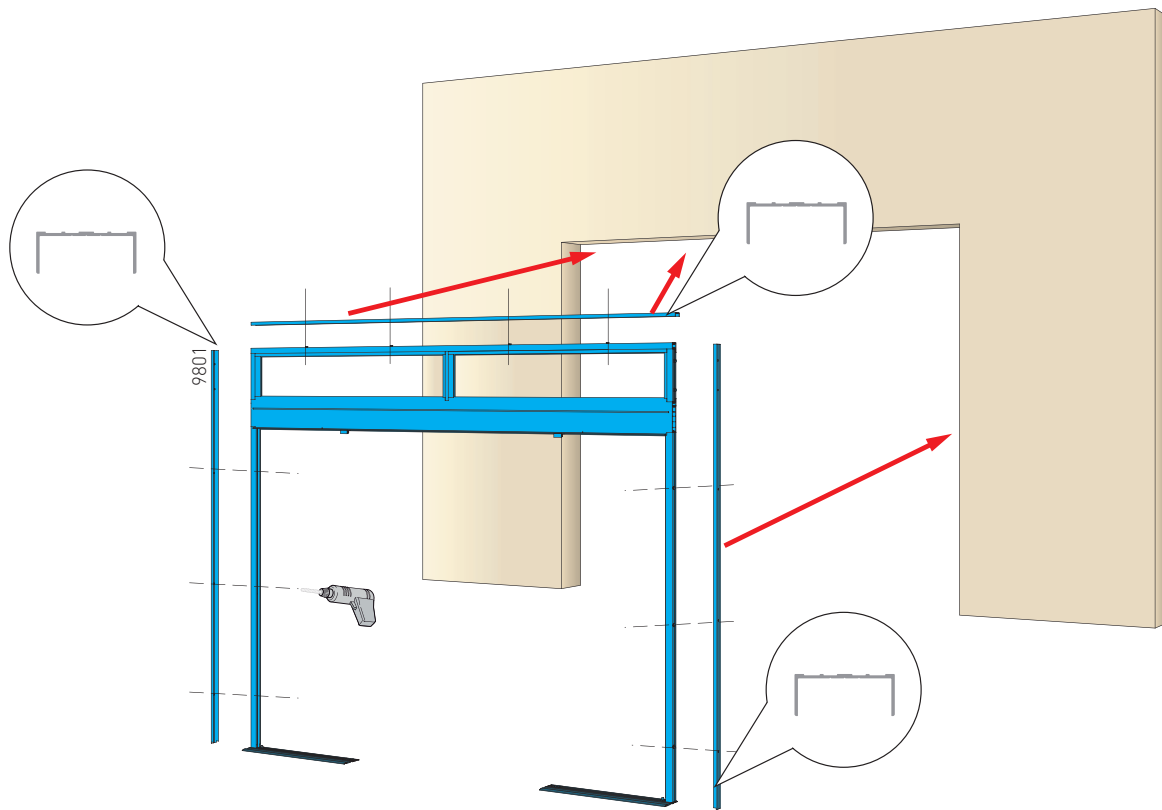

4 Frame, beam and overlight installation

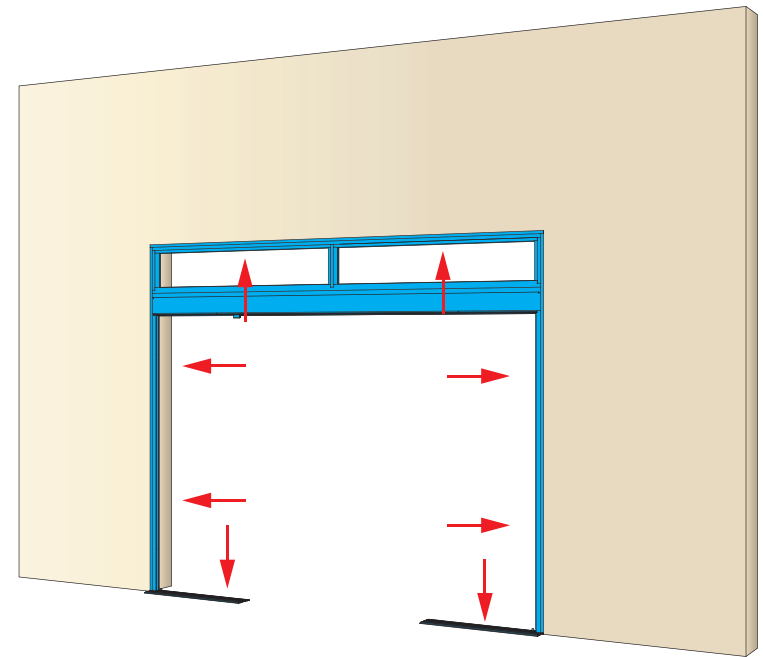

6. Installation instructions for two moving door wings and two fixed door wings with beam and overlight

5 Fixed door wing installation

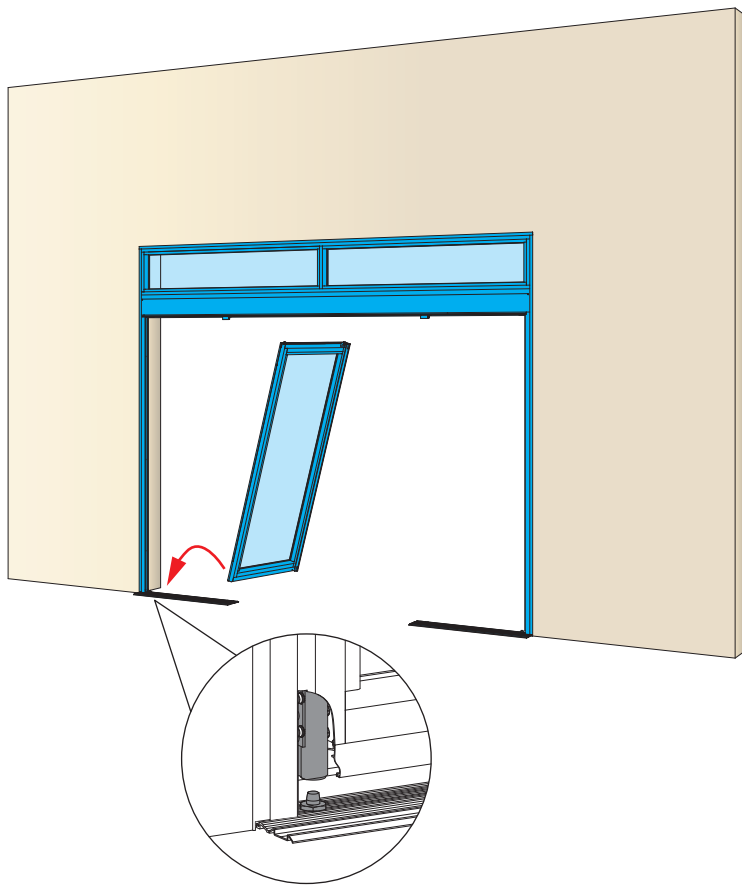

6 Fixed door wing installation

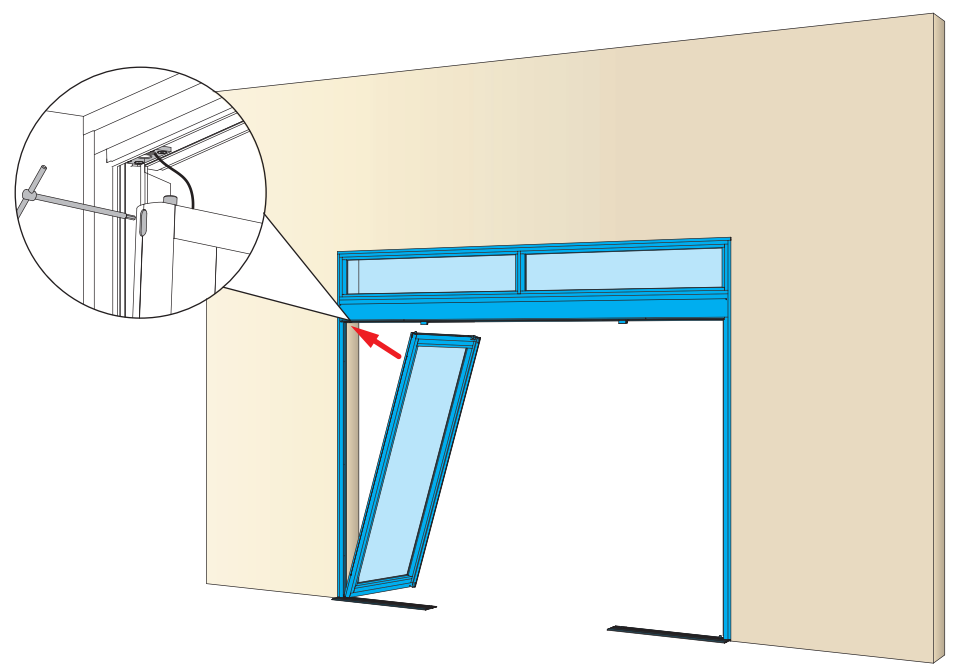

## 6. Installation instructions for two moving door wings and two fixed door wings with beam and overlight

### 7 Fixed door wing regulation

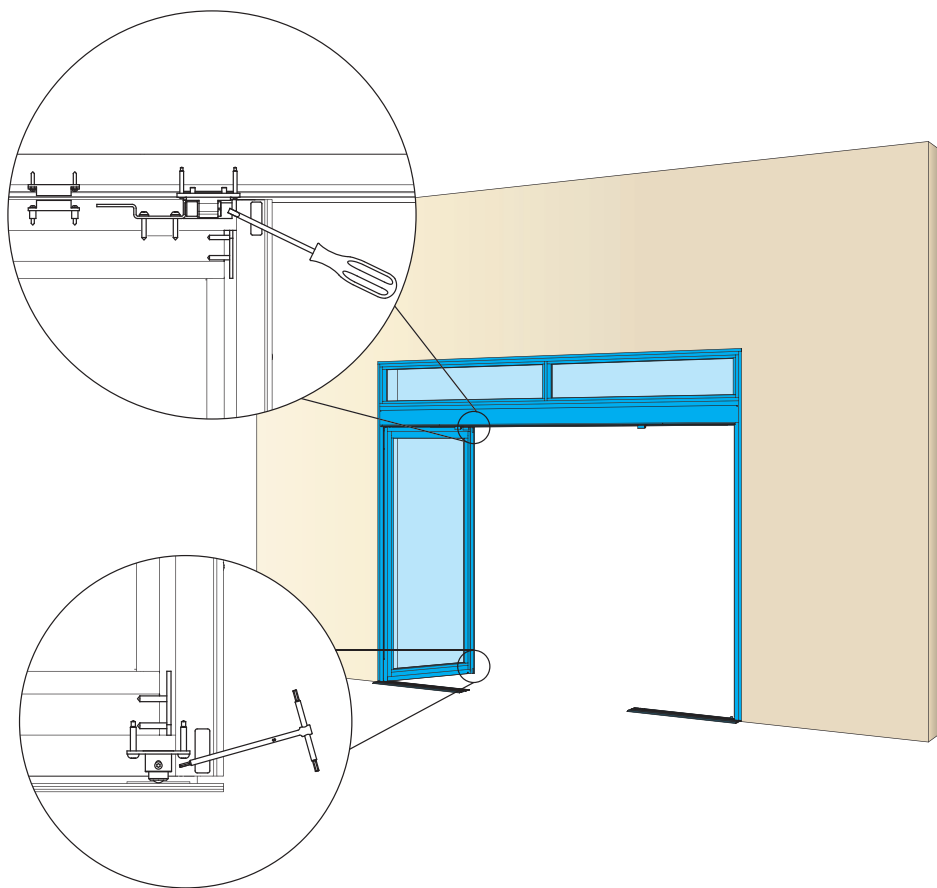

### 8 Fixed door wing installation

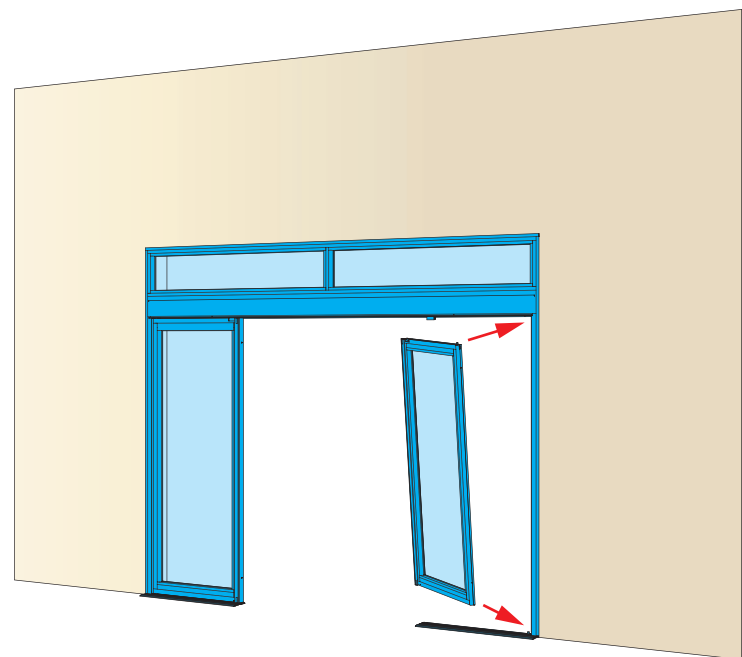

6. Installation instructions for two moving door wings and two fixed door wings with beam and overlight

9 Installation of automation

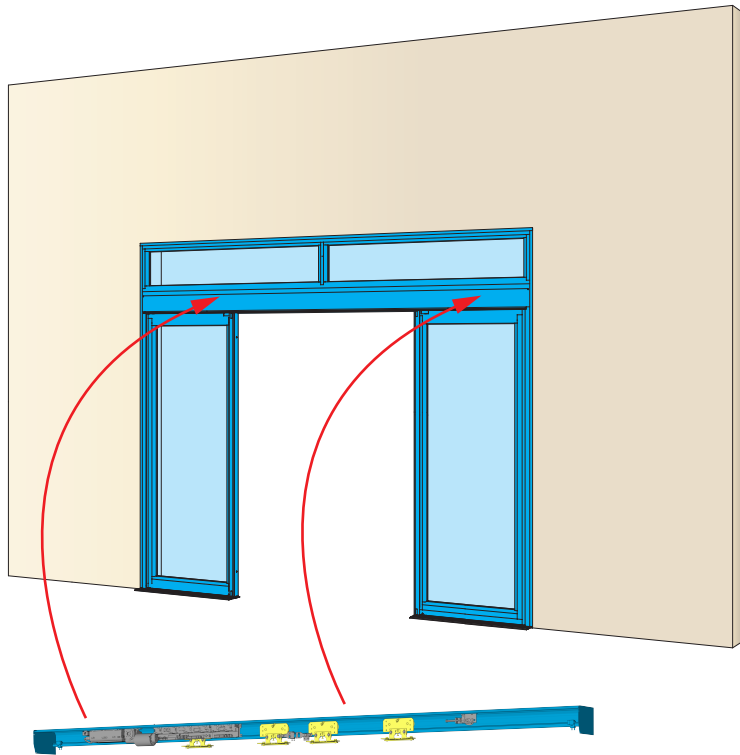



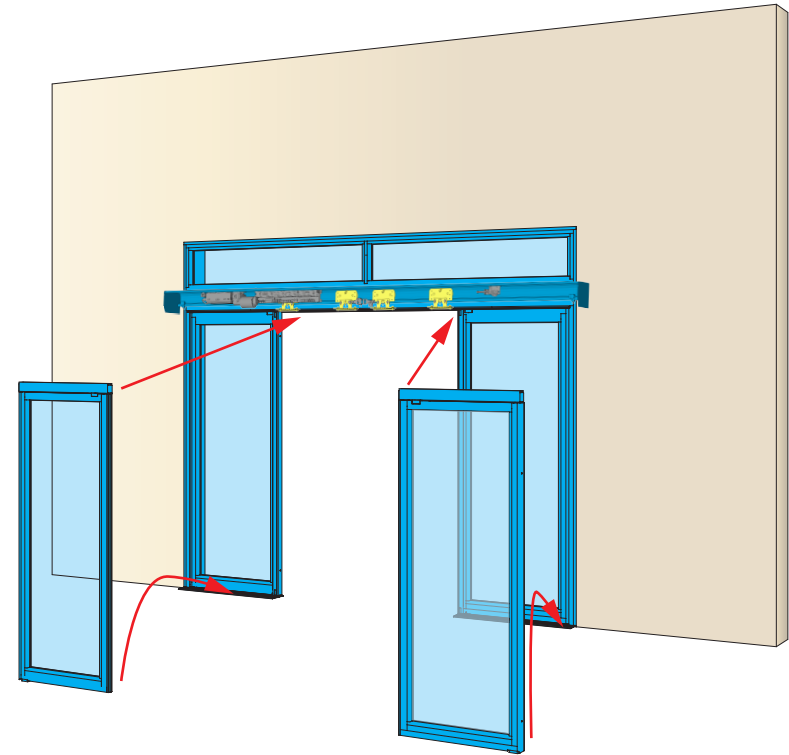



10 Door wing installation





**NOTE 1:** in compliance with the EN 16005 Standard, transparent glass panels must be marked. The application of stickers complies with the provisions of the Standard regarding accident prevention.

- EN**  The crossed-out wheeled bin symbol indicates that the product should be disposed of separately from household waste. The product should be handed in for recycling in accordance with local environmental regulations for waste disposal. By separating a marked item from household waste, you will help reduce the volume of waste sent to incinerators or landfill and minimize any potential negative impact on human health and the environment.
- IT**  Il simbolo del cassonetto barrato indica che il prodotto non può essere eliminato con i comuni rifiuti domestici. Il prodotto deve essere riciclato nel rispetto delle norme ambientali locali per lo smaltimento dei rifiuti. Separando un prodotto contrassegnato da questo simbolo dai rifiuti domestici, si aiuterà a ridurre il volume dei rifiuti destinati agli inceneritori o alle discariche, minimizzando così qualsiasi possibile impatto negativo sulla salute umana e sull'ambiente.
- FR**  Le symbole de la poubelle barrée indique que le produit ne peut pas être éliminé avec les ordures ménagères ordinaires. Il doit être recyclé conformément à la réglementation environnementale locale en matière de déchets. En triant les produits portant ce pictogramme, vous contribuez à réduire le volume des déchets incinérés ou enfouis, et à diminuer tout impact négatif sur la santé humaine et l'environnement.
- DE**  Das Symbol mit der durchgestrichenen Abfalltonne bedeutet, dass das Produkt getrennt vom Haushaltsabfall entsorgt werden muss. Das Produkt muss gemäß der örtlichen Entsorgungsvorschriften der Wiederverwertung zugeführt werden. Durch separate Entsorgung des Produkts tragen Sie zur Minderung der Verbrennung oder Menge des Deponieabfalls bei und reduzieren eventuelle negative Auswirkungen auf die menschliche Gesundheit und die Umwelt.
- ES**  La imagen del cubo de basura tachado indica que el producto no debe formar parte de los residuos habituales del hogar. Se debe reciclar según la normativa ambiental local de eliminación de residuos. Cuando se separan los productos que llevan esta imagen, se contribuye a reducir el volumen de residuos que se incineran o se envían a vertederos y se minimiza el impacto negativo sobre la salud y el medio ambiente.
- PT**  O símbolo do caixote do lixo com o sinal de proibição indica que esse artigo deve ser separado dos resíduos domésticos convencionais. Deve ser entregue para reciclagem de acordo com as regulamentações ambientais locais para tratamento de resíduos. Ao separar um artigo assinalado dos resíduos domésticos, ajuda a reduzir o volume de resíduos enviados para os incineradores ou aterros, minimizando o potencial impacto negativo na saúde pública e no ambiente.

- EN** All the rights concerning this material are the exclusive property of ASSA ABLOY Entrance Systems AB. Although the contents of this publication have been drawn up with the greatest care, ASSA ABLOY Entrance Systems AB cannot be held responsible in any way for any damage caused by mistakes or omissions. We reserve the right to make changes without prior notice. Copying, scanning or changing in any way is expressly forbidden unless authorised in writing by ASSA ABLOY Entrance Systems AB.
- IT** Tutti i diritti relativi a questo materiale sono di proprietà esclusiva di ASSA ABLOY Entrance Systems AB. Sebbene i contenuti di questa pubblicazione siano stati redatti con la massima cura, ASSA ABLOY Entrance Systems AB non può assumersi alcuna responsabilità per danni causati da eventuali errori o omissioni in questa pubblicazione. Ci riserviamo il diritto di apportare eventuali modifiche senza preavviso. Copie, scansioni, ritocchi o modifiche sono espressamente vietate senza un preventivo consenso scritto di ASSA ABLOY Entrance Systems AB.
- FR** Tous les droits relatifs à ce matériel sont la propriété exclusive d'ASSA ABLOY Entrance Systems AB. Bien que les contenus de cette publication aient été rédigés avec le plus grand soin, ASSA ABLOY Entrance Systems AB ne saurait être tenue responsable en cas de dommages dérivant d'erreurs ou d'omissions éventuelles. Nous nous réservons le droit d'apporter des modifications éventuelles sans préavis. Toute copie, reproduction, retouche ou modification est expressément interdite sans l'accord écrit préalable d'ASSA ABLOY Entrance Systems AB.
- DE** Alle Rechte an diesen Unterlagen sind ausschließliches Eigentum von ASSA ABLOY Entrance Systems AB. Obwohl der Inhalt dieser Veröffentlichung mit äußerster Sorgfalt verfasst wurde, kann ASSA ABLOY Entrance Systems AB keine Haftung für Schäden übernehmen, die durch mögliche Fehler oder Auslassungen in dieser Veröffentlichung verursacht wurden. Wir behalten uns das Recht vor, eventuelle Änderungen ohne Vorankündigung anzubringen. Kopien, Scannen, Überarbeitungen oder Änderungen sind ohne vorherige schriftliche Zustimmung durch ASSA ABLOY Entrance Systems AB ausdrücklich verboten.
- ES** Todos los derechos relativos a este material son propiedad exclusiva de ASSA ABLOY Entrance Systems AB. Aunque los contenidos de esta publicación se hayan redactado con la máxima atención, ASSA ABLOY Entrance Systems AB no se asume ninguna responsabilidad por los daños debidos a posibles errores u omisiones en esta publicación. Nos reservamos el derecho de aportar eventuales modificaciones sin previo aviso. Copias, escaneos, retoques o modificaciones están expresamente prohibidos sin una autorización previa por escrito de ASSA ABLOY Entrance Systems AB.
- PT** Todos os direitos deste material são de propriedade exclusiva da ASSA ABLOY Entrance Systems AB. Embora o conteúdo desta publicação tenha sido compilado com o maior cuidado, a ASSA ABLOY Entrance Systems AB não pode assumir qualquer responsabilidade por danos causados por eventuais erros ou omissões nesta publicação. Reservamo-nos o direito de fazer alterações sem aviso prévio. Cópias, digitalizações, alterações ou modificações são expressamente proibidas sem o consentimento prévio por escrito da ASSA ABLOY Entrance Systems AB.



ASSA ABLOY Entrance Systems AB  
Lodjursgatan 10  
SE-261 44, Landskrona  
Sweden  
© ASSA ABLOY